

KCSE MADE FAMILIAR

MATHEMATICS

Topically Analysed KCSE past Questions

For Marking Schemes

Call/TextWhatsapp 0705525657

FORM 1

TOPIC 1

NUMBERS

PAST KCSE QUESTIONS ON THE TOPIC

1. Mogaka and Onduso together can do a piece of work in 6 days. Mogaka, working alone, takes 5 days longer than Onduso. How many days does it take Onduso to do the same work alone?

2. (a) Evaluate

$$\underline{-8 \div 2 + 12 \times 9 - 4 \times 6}$$

$$56 \div 7 \times 2$$

(b) Simplify the expression

$$5a - 4b - 2(a - 2b + c)$$

3. Evaluate

$$\underline{28 - (-18)} - \underline{15 - (-2)(-6)}$$

$$-2 \quad 3$$

4. Three people Odawa, Mliwa and Amina contributed money to purchase a flour mill. Odawa contributed $\frac{1}{3}$ of the total amount, Mliwa contributed $\frac{3}{8}$ of the remaining amount and Amina contributed the rest of the money. The difference in contribution between Mliwa and Amina was Kshs 40000. Calculate the price of the flour mill.

5. Evaluate:

$$\underline{-12 \div (-3) \times 4 - (-20)}$$

$$-6 \times 6 \div 3 + (-6)$$

6. Without using logarithm tables or a calculator evaluate.

$$\sqrt{\frac{384.16 \times 0.0625}{96.04}}$$

7. Evaluate without using mathematical table

$$1000 \left(\sqrt{0.0128} \right)$$

8. Express the numbers 1470 and 7056, each as a product of its prime factors.

Hence evaluate: $\frac{1470^2}{\sqrt{7056}}$

Leaving the answer in prime factor form

9. Evaluate:

$$\frac{3}{4} + 1\frac{5}{7} \div \frac{4}{7} \text{ of } 2\frac{1}{3}$$

$$(1\frac{3}{7} - \frac{5}{8}) \times \frac{2}{3}$$

10. Pipes A can fill an empty water tank in 3 hours while pipe B can fill the same tank in 6 hours. When the tank is full it can be emptied by pipe C in 8 hours. Pipe A and B are opened at the same time when the tank is empty. If one hour later, pipe C is also opened, find the total time taken to fill the tank.
11. In a fund- raising committee of 45 people the ratio of men to women 7:2. Find the number of women required to join the existing committee so that the ratio of men to women is changes to 5:4
12. Without using mathematical tables or calculators, evaluate

$$\frac{\sqrt{3 \times 675 \times 135}}{\sqrt{2025}}$$

13. All prime numbers less than ten are arranged in descending order to form a number
- (a) Write down the number formed
- (b) What is the total value of the second digit?
14. Evaluate without using mathematical tables or a calculator $0.0084 \times 1.23 \times 3.5$.

Expressing the answer as a fraction in its simplest form.

15. Evaluate $\frac{1}{3}$ of $(2\frac{3}{4} - 5\frac{1}{2}) \times 3\frac{6}{7} \div \frac{9}{4}$

16. Evaluate without using mathematical tables or the calculator

$$\sqrt{\frac{(.0.0625 \times 2.56)}{0.25 \times 0.08 \times 0.5}}$$

17. Evaluate without using mathematical tables or the calculator

$$\frac{1.9 \times 0.032}{20 \times 0.0038}$$

18. Evaluate $2\frac{3}{4} \times \frac{8}{33}$

$$3 + (5\frac{2}{5} \div \frac{9}{25})$$

19. Without using tables or calculators evaluate

$$\sqrt{\frac{153 \times 0.18}{0.68 \times 0.32}}$$

20. Without using mathematical tables, evaluate

$$1.2 \times \sqrt{\frac{0.0324}{0.0072}}$$

21. Simplify $\frac{2}{3}$ of $12 - (1\frac{1}{3} + 1\frac{1}{4})$

22. If $x = 2$, Find the value of $x^3 - 5x^2 - 4x + 3$

23. If $X = \frac{1}{2}$, $y = \frac{1}{4}$ and $z = \frac{2}{3}$ Find the value of

$$\frac{x + yz}{y - xz}$$

24. Find a and b if $3.168 = 3^{a/b}$

25. Find the greatest common factor of $x^8 y^2$ and $4xy^4$. Hence factorize completely the expression $x^3 y^2 - 4xy^4$

26. A hot water tap can fill a bath in 5 minutes while a cold water tap can fill the same bath in 3 minutes. The drain pipe can empty the full bath in $3\frac{3}{4}$ minutes. The two taps and the drain pipe are fully open for $1\frac{1}{2}$ minutes after which the drain pipe are fully open for $1\frac{1}{2}$ minutes after which the drain pipe is closed. How much will take it take to fill the bath?

27. A farmer distributed his cabbages as follows

A certain hospital received a quarter of the total number of bags. A nearby school received half of the remainder. A green grocer received a third of what the school received. What remained were six bags more than what the green

grocer received. How many bags of cabbages did the farmer have?

TOPIC 2

ALGEBRAIC EXPRESSIONS

PAST KCSE QUESTIONS ON THE TOPIC

1. Given that $y = \frac{2x - z}{x + 3z}$ express x in terms of y and z

$x + 3z$ express x in terms of y and z

2. Simplify the expression

$$\frac{x-1}{x} - \frac{2x+1}{3x}$$

Hence solve the equation

$$\frac{x-1}{x} - \frac{2x+1}{3x} = \frac{2}{3}$$

3. Factorize $a^2 - b^2$

Hence find the exact value of $2557^2 - 2547^2$

4. Simplify $p^2 - 2pq + q^2$

$$P^3 - pq^2 + p^2 q - q^3$$

5. Given that $y = 2x - z$, express x in terms of y and z.

Four farmers took their goats to a market. Mohammed had two more goats as Koech had 3 times as many goats as Mohammed, whereas Odupoy had 10 goats less than both Mohammed and Koech.

- (i) Write a simplified algebraic expression with one variable, representing the total number of goats.
- (ii) Three butchers bought all the goats and shared them equally. If each

butcher got 17 goats, how many did odupoy sell to the butchers?

6. Factorize completely $3x^2 - 2xy - y^2$

7. Solve the equation

$$\frac{1}{4x} = \frac{5}{6x} - 7$$

$$4x \quad 6x$$

8. Simplify

$$\frac{a}{2(a+b)} + \frac{b}{2(a-b)}$$

$$2(a+b)$$

$$2(a-b)$$

9. Factorize completely $28x^2 + 3x - 1$

10. Three years ago, Juma was three times as old. As Ali in two years time, the sum of their ages will be 62. Determine their ages

11. Two pairs of trousers and three shirts cost a total of Kshs. Five such pairs of trousers and two shirt cost a total of Kshs 810. Find the price of a pair of trouser and shirt.

TOPIC 3

RATES, RATIO PERCENTAGE AND PROPORTION

PAST KCSE QUESTIONS ON THE TOPIC

1. Akinyi bought maize and beans from a wholesaler. She then mixed the maize and beans in the ratio 4:3 she bought the maize at Kshs 21 per kg and the beans 42 per kg.

If she was to make a profit of 30%. What should be the selling price of 1 kg of the mixture?

2. Water flows from a tap at the rate of 27 cm^3 per second into a rectangular container of length 60 cm, breadth 30 cm and height 40 cm. If at 6.00 PM the container was half full, what will be the height of water at 6.04 pm?
3. Two businessmen jointly bought a minibus which could ferry 25 paying passengers when full. The fare between two towns A and B was Kshs 80 per passenger for one way. The minibus made three round trips between the two towns daily. The cost of fuel was Kshs 1500 per day. The driver and the conductor were paid daily allowances of Kshs 200 and Kshs 150 respectively. A further Kshs 4000 per day was set aside for maintenance, insurance and loan repayment.
 - (a)
 - (i) How much money was collected from the passengers that day?
 - (ii) How much was the net profit?
 - (b) On another day, the minibus was 80% full on the average for the three round trips, how much did each businessman get if the day's profit was shared in the ratio 2:3?
4. Wainaina has two dairy farms, A and B. Farm A produces milk with $3 \frac{1}{4}$ percent fat and farm B produces milk with $4 \frac{1}{4}$ percent fat.
 - (a) Determine
 - (i) The total mass of milk fat in 50 kg of milk from farm A and 30 kg of milk from farm B
 - (ii) The percentage of fat in a mixture of 50kg of milk A and 30kg of milk from B

- (b) The range of values of mass of milk from farm B that must be used in a 50kg mixture so that the mixture may have at least 4 percent fat.
5. In the year 2001, the price of a sofa set in a shop was Kshs 12,000
- (a) Calculate the amount of money received from the sales of 240 sofa sets that year.
- (b) (i) In the year 2002 the price of each sofa set increased by 25% while the number of sets sold decreased by 10%. Calculate the percentage increase in the amount received from the sales
- (ii) If the end of year 2002, the price of each sofa set changed in the ratio 16: 15, calculate the price of each sofa set in the year 2003.
- (c) The number of sofa sets sold in the year 2003 was P% less than the number sold in the year 2001.
- Calculate the value of P, given that the amounts received from sales in the two years were equal.
6. A solution whose volume is 80 litres is made up of 40% of water and 60% of alcohol. When x litres of water is added, the percentage of alcohol drops to 40%.
- (a) Find the value of x
- (b) Thirty litres of water is added to the new solution. Calculate the percentage of alcohol in the resulting solution
- (c) If 5 litres of the solution in (b) above is added to 2 litres of the original solution, calculate in the simplest form, the ratio of water to that of alcohol in the resulting solution.
7. Three business partners, Asha, Nangila and Cherop contributed Kshs 60,000,

Kshs 85,000 and Kshs 105, 000 respectively. They agreed to put 25% of the profit back into business each year. They also agreed to put aside 40% of the remaining profit to cater for taxes and insurance. The rest of the profit would then be shared among the partners in the ratio of their contributions. At the end of the first year, the business realized a gross profit of Kshs 225, 000.

- (a) Calculate the amount of money Cherop received more than Asha at the end of the first year.
 - (b) Nangila further invested Kshs 25,000 into the business at the beginning of the second year. Given that the gross profit at the end of the second year increased in the ratio 10:9, calculate Nangila's share of the profit at the end of the second year.
8. Kipketer can cultivate a piece of land in 7 hrs while Wanjiku can do the same work in 5 hours. Find the time they would take to cultivate the piece of land when working together.
9. Mogaka and Ondiso working together can do a piece of work in 6 days. Mogaka working alone, takes 5 days longer than Onduso. How many days does it take Onduso to do the work alone.
10. A certain amount of money was shared among 3 children in the ratio 7:5:3 the largest share was Kshs 91. Find the
- (a) Total amount of money
 - (b) Difference in the money received as the largest share and the smallest

share.

TOPIC 4

MEASUREMENT

PAST KCSE QUESTIONS ON THE TOPIC

1. The figure below shows a portable kennel

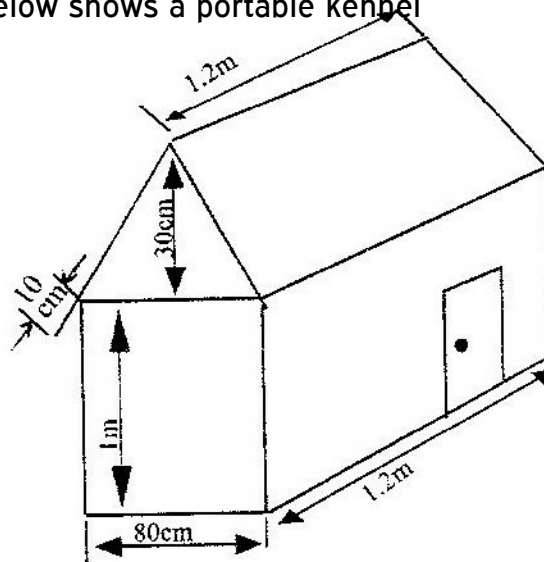

- (a) Calculate
- (i) The total surface area of the walls and the floor (include the door as part of the wall).
 - (ii) The total surface area of the roof
- (b) The cost of roofing is Kshs 300 per square metre and that of making walls and floor Kshs 350 per square metre. Find the cost of making the kennel.
2. The enclosed region shown in the figure below represents a ranch draw to scale. The actual area of the ranch is 1075 hectares

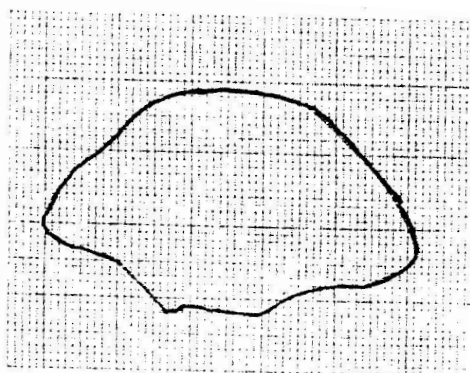

F

525657

- (a) Estimate the area of the enclosed region in square centimeters
- (b) Calculate the linear scale used
3. The figure below shows an octagon obtained by cutting off four congruent triangles from a rectangle measuring 19.5 by 16.5 cm

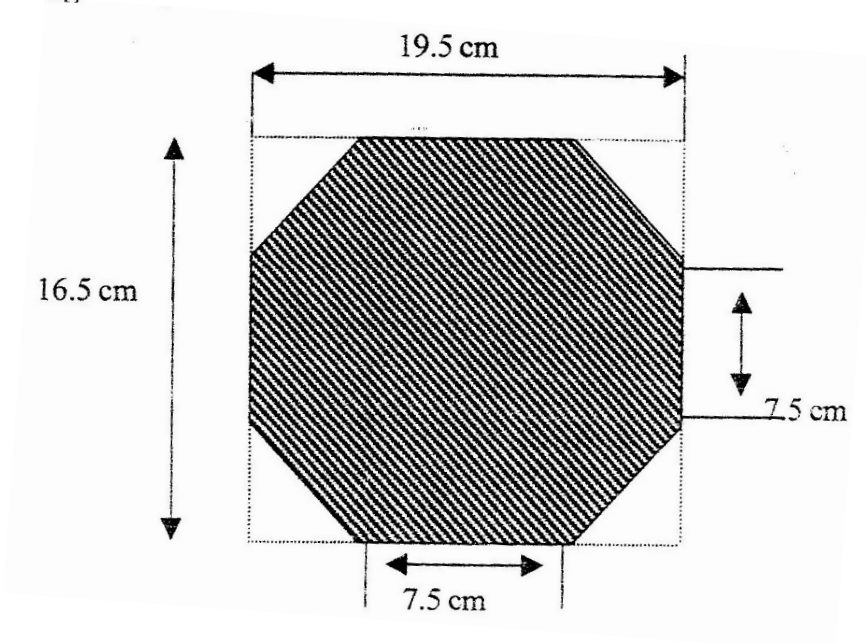

Calculate the area of the octagon

4. The length of a hollow cylindrical pipe is 6 metres. Its external diameter is 11cm and has a thickness of 1 cm. Calculate the, volume in cm^3 of the materials used to make the pipe. Take π as 3.142.
5. The area of rhombus is 60 cm^2 . Given that one of its diagonals is 15 cm long, calculate the perimeter of the rhombus.
6. A cylindrical piece of wood of radius 4.2 cm and length 150 cm is cut lengthwise into two equal pieces.

Calculate the surface area of one piece

(Take π as $\frac{22}{7}$)

7. The diagram below (not drawn to scale) represents the cross section of a solid prism of height 8.0 cm

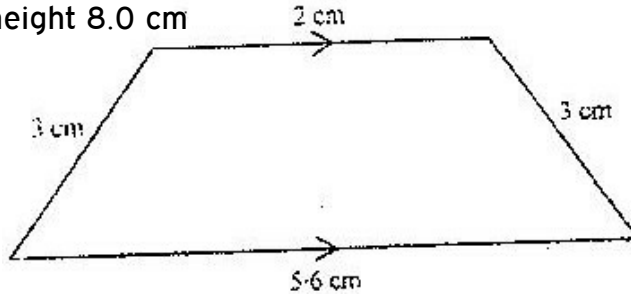

- (a) Calculate the volume of the prism
- (b) Given that the density of the prism is 5.75 g/cm^3 , calculate its mass in grams
- (c) A second prism is similar to the first one but is made of different material. The volume of the second prism is 246.24 cm^3
- (i) Calculate the area of cross section of the second prism
- (ii) Given the ratio of the mass of the first prism to the second is 2:5, find the density of the second prism.
8. A square brass plate is 2 mm thick and has a mass of 1.05 kg. The density of the brass is 8.4 g/cm^3 . Calculate the length of the plate in centimeters.
9. Two cylindrical containers are similar. The larger one has internal cross-section area of 45 cm^2 and can hold 0.95 litres of liquid when full. The smaller container has internal cross-section area of 20 cm^2
- (a) Calculate the capacity of the smaller container
- (b) The larger container is filled with juice to a height of 13 cm. Juice is then drawn from it and empties into the smaller container until the depth of the juice in both containers are equal. Calculate the depth of juice in each container.

- (c) One fifth of the juice in the larger container in part (b) above is further drawn and emptied into the smaller container. Find the differences in the depths of the juice in the two containers.
10. Pieces of soap are packed in a cuboid container measuring 36 cm by 24 cm by 18 cm. Each piece of soap is similar to the container. If the linear scale factor between the container and the soap is $\frac{1}{6}$. Find the volume of each piece of soap.
11. A cylindrical water tank is of diameter 7 metres and height 2.8 metres
- (a) Find the capacity of the water tank in litres
- (b) Six members of family use 15 litres each per day. Each day 80 litres are used for cooking and washing. And a further 60 litres are wasted. Find the number of complete days a full tank would last the family
- (c) Two members of the family were absent for 90 days. During the 90 days, wastage was reduced by 20% but cooking and washing remained the same. Calculate the number of days a full tank would now last the family
12. A company is to construct parking bay whose area is 135m^2 . It is to be covered with a concrete slab of uniform thickness of 0.15m. To make the slab cement, ballast and sand are to be mixed so that their masses are in the ratio 1:4:4 the mass of 1m^3 of dry slab is 2,500 kg.
- (a) Calculate
- (i) The volume of the slab
- (ii) The mass of dry slab

- (iii) The mass of cement to be used
- (b) If one bag of cement is 50kg. Find the number of bags to be purchased
- (c) If a lorry carries 7 tonnes of sand, calculate the number of lorries of sand to be purchased
13. An Artisan has 63 kg of metal of density 7000 kg/m^3 . He intends to use to make a rectangular pipe with external dimensions 12 cm by 15 cm and internal dimensions 10cm by 12 cm. Calculate the length of the pipe in metres.
14. The figure below represents hollow cylinder. The internal and external radii are estimated to be 6 cm and 8 cm respectively, to the nearest whole number. The height of the cylinder is exactly 14 cm.

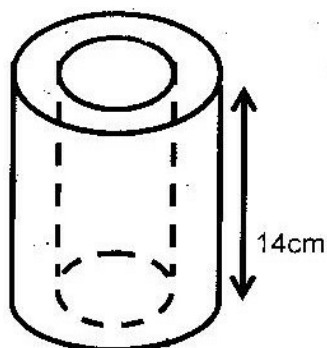

- (a) Determine the exact values for internal and external radii which will give maximum volume of the material used.
- (b) Calculate the maximum possible volume of the material used. Take the value of π to be $\frac{22}{7}$
15. Calculate the volume of a prism whose length is 25 cm and whose length is 25

cm and whose cross-section is an equilateral triangle of side 3 cm

16. The figure below shows a square of side 16.5 cm by cutting off four congruent triangles from a rectangle

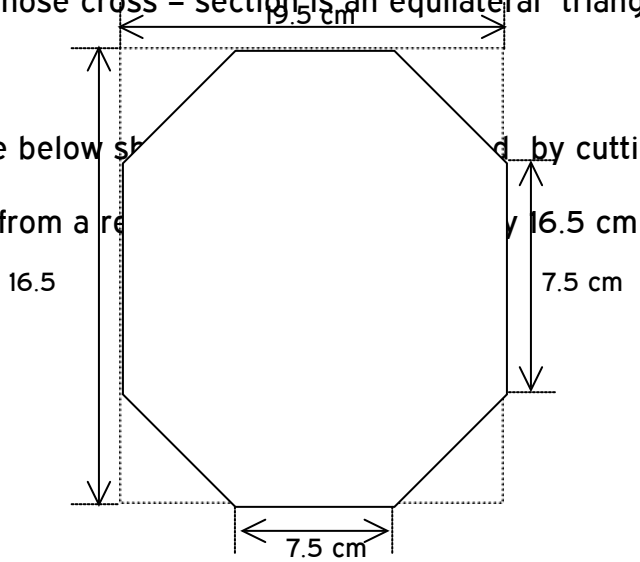

Calculate the area of the octagon

17. The figure below represents a kite ABCD, $AB = AD = 15$ cm. the diagonals BD and AC intersect at O, $AC = 30$ cm and $AO = 12$ cm.

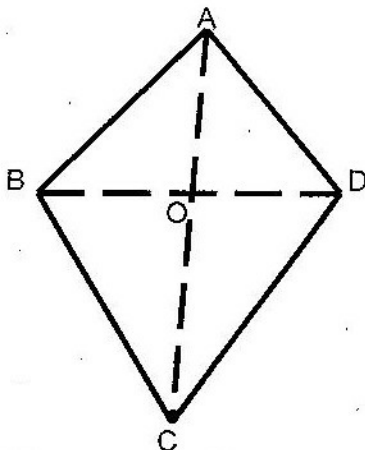

F

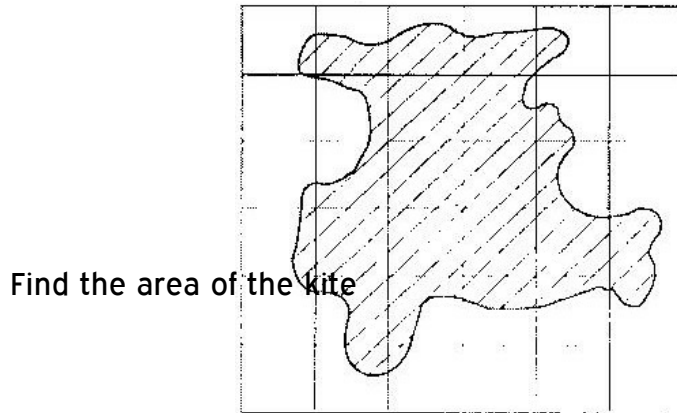

18. The figure below is a map of a forest drawn on a grid of 1 cm squares

- (a) Estimate the area of the map in square centimeters if the scale of the map is 1: 50, 000; estimate the area of the forest in hectares.

TOPIC 5:

LINEAR EQUATIONS

PAST KCSE QUESTIONS ON THE TOPIC

1. A cloth dealer sold 3 shirts and 2 trousers for Kshs 840 and 4 shirts and 5 trousers for Kshs 1680 find the cost of 1 shirt and the cost of 1 trouser
2. Solve the simultaneous equations

$$2x - y = 3$$

$$x^2 - xy = -4$$

3. The cost of 5 skirts and blouses is Kshs 1750. Mueni bought three of the skirts and one of the blouses for Kshs 850. Find the cost of each item.
4. Akinyi bought three cups and four spoons for Kshs 324. Wanjiru bought five cups and Fatuma bought two spoons of the same type as those bought by Akinyi, Wanjiku paid Kshs 228 more than Fatuma. Find the price of each cup and each spoon.
5. Mary has 21 coins whose total value is Kshs. 72. There are twice as many five shillings coins as there are ten shilling coins. The rest one shillings coins. Find the number of ten shillings coins that Mary has. (4 mks)
6. The mass of 6 similar art books and 4 similar biology books is 7.2 kg. The mass of 2 such art books and 3 such biology books is 3.4 kg. Find the mass of one art book and the mass of one biology book
7. Karani bought 4 pencils and 6 biros – pens for Kshs 66 and Tachora bought 2 pencils and 5 biro pens for Kshs 51.
 - (a) Find the price of each item
 - (b) Musoma spent Kshs. 228 to buy the same type of pencils and biro – pens if the number of biro pens he bought were 4 more than the number of pencils, find the number of pencils bought.
8. Solve the simultaneous equations below
$$2x - 3y = 5$$
$$-x + 2y = -3$$
9. The length of a room is 4 metres longer than its width. Find the length of the room if its area is 32m^2
10. Hadija and Kagendo bought the same types of pens and exercise books from

the same types of pens and exercise books from the same shop. Hadija

bought 2 pens and 3 exercise books for Kshs 78. Kagendo bought 3 pens and 4 exercise books for Kshs 108.

Calculate the cost of each item

11. In fourteen years time, a mother will be twice as old as her son. Four years ago, the sum of their ages was 30 years. Find how old the mother was, when the son was born.

12. Three years ago Juma was three times as old as Ali. In two years time the sum of their ages will be 62. Determine their ages.

13. Two pairs of trousers and three shirts costs a total of Kshs 390. Five such pairs of trousers and two shirts cost a total of Kshs 810. Find the price of a pair of trousers and a shirt.

14. A shopkeeper sells two- types of pangas type x and type y. Twelve x pangas and five type y pangas cost Kshs 1260, while nine type x pangas and fifteen type y pangas cost 1620. Mugala bought eighteen type y pangas. How much did he pay for them?

TOPIC 6:

COMMERCIAL ARITHMETICS

PAST KCSE QUESTIONS ON THE TOPIC

1. The cash prize of a television set is Kshs 25000. A customer paid a deposit of Kshs 3750. He repaid the amount owing in 24 equal monthly installments. If he was charged simple interest at the rate of 40% p.a how much was each installment?
2. Mr Ngeny borrowed Kshs 560,000 from a bank to buy a piece of land. He was required to repay the loan with simple interest for a period of 48 months. The repayment amounted to Kshs 21,000 per month.
Calculate
 - (a) The interest paid to the bank
 - (b) The rate per annum of the simple interest
3. A car dealer charges 5% commission for selling a car. He received a commission of Kshs 17,500 for selling car. How much money did the owner receive from the sale of his car?
4. A company saleslady sold goods worth Kshs 240,000 from this sale she earned a commission of Kshs 4,000
 - (a) Calculate the rate of commission
 - (b) If she sold good whose total marked price was Kshs 360,000 and allowed a discount of 2% calculate the amount of commission she received.
5. A business woman bought two bags of maize at the same price per bag. She discovered that one bag was of high quality and the other of low quality. On the high quality bag she made a profit by selling at Kshs 1,040, whereas on the low quality bag she made a loss by selling at Kshs 880. If the profit was three times the loss, calculate the buying price per bag.
6. A salesman gets a commission of 2.4 % on sales up to Kshs 100,000. He gets

an additional commission of 1.5% on sales above this. Calculate the commission he gets on sales worth Kshs 280,000.

7. Three people Koris, Wangare and Hassan contributed money to start a business. Korir contributed a quarter of the total amount and Wangare two fifths of the remainder.

Hassan's contribution was one and a half times that of Koris. They borrowed the rest of the money from the bank which was Kshs 60,000 less than Hassan's contribution. Find the total amount required to start the business.

8. A Kenyan tourist left Germany for Kenya through Switzerland. While in Switzerland he bought a watch worth 52 deutsche Marks. Find the value of the watch in:

- (a) Swiss Francs.
- (b) Kenya Shillings

Use the exchange rates below:

1 Swiss Franc = 1.28 Deutsche Marks.

1 Swiss Franc = 45.21 Kenya Shillings

9. A salesman earns a basic salary of Kshs. 9000 per month
In addition he is also paid a commission of 5% for sales above Kshs 15000
In a certain month he sold goods worth Kshs. 120, 000 at a discount of $2\frac{1}{2}$ %.
Calculate his total earnings that month

10. In this question, mathematical table should not be used

A Kenyan bank buys and sells foreign currencies as shown below

Buying	Selling
(In Kenya shillings)	In Kenya Shillings

1 Hong Kong dollar	9.74	9.77
1 South African rand	12.03	12.11

A tourists arrived in Kenya with 105 000 Hong Kong dollars and changed the whole amount to Kenyan shillings. While in Kenya, she pent Kshs 403 897 and changed the balance to South African rand before leaving for South Africa. Calculate the amount, in South African rand that she received.

11. A Kenyan businessman bought goods from Japan worth 2, 950 000 Japanese yen. On arrival in Kenya custom duty of 20% was charged on the value of the goods.

If the exchange rates were as follows

1 US dollar = 118 Japanese Yen

1 US dollar = 76 Kenya shillings

Calculate the duty paid in Kenya shillings

12. Two businessmen jointly bought a minibus which could ferry 25 paying passengers when full. The fare between two towns A and B was Kshs. 80 per passenger for one way. The minibus made three round trips between the two towns daily. The cost of fuel was Kshs 1500 per day. The driver and the conductor were paid daily allowances of Kshs 200 and Kshs 150 respectively. A further Kshs 4000 per day was set aside for maintenance.

(a) One day the minibus was full on every trip.

(i) How much money was collected from the passengers that day?

(ii) How much was the net profit?

(b) On another day, the minibus was 80% on the average for the three round

trips. How much did each business get if the days profit was shared in the ratio 2:3?

13. A traveler had sterling pounds 918 with which he bought Kenya shillings at the rate of Kshs 84 per sterling pound. He did not spend the money as intended. Later, he used the Kenyan shillings to buy sterling pound at the rate of Kshs. 85 per sterling pound. Calculate the amount of money in sterling pounds lost in the whole transaction.
14. A commercial bank buys and sells Japanese Yen in Kenya shillings at the rates shown below
- | | |
|---------|--------|
| Buying | 0.5024 |
| Selling | 0.5446 |
- A Japanese tourist at the end of his tour of Kenya was left with Kshs. 30000 which he converted to Japanese Yen through the commercial bank. How many Japanese Yen did he get?
15. In the month of January, an insurance salesman earned Kshs. 6750 which was commission of 4.5% of the premiums paid to the company.
- (a) Calculate the premium paid to the company.
- (b) In February the rate of commission was reduced by $66\frac{2}{3}\%$ and the premiums reduced by 10% calculate the amount earned by the salesman in the month of February

16. Akinyi, Bundi, Cura and Diba invested some money in a business in the ratio of 7:9:10:14 respectively. The business realized a profit of Kshs 46800. They shared 12% of the profit equally and the remainder in the ratio of their contributions. Calculate the total amount of money received by Diba.
17. A telephone bill includes Kshs 4320 for a local calls Kshs 3260 for trunk calls and rental charge Kshs 2080. A value added tax (V.A.T) is then charged at 15%, Find the total bill.
18. During a certain period. The exchange rates were as follows
- 1 sterling pound = Kshs 102.0
- 1 sterling pound = 1.7 us dollar
- 1 U.S dollar = Kshs 60.6
- A school management intended to import textbooks worth Kshs 500,000 from UK. It changed the money to sterling pounds. Later the management found out that the books the sterling pounds to dollars. Unfortunately a financial crisis arose and the money had to be converted to Kenya shillings. Calculate the total amount of money the management ended up with.
19. A fruiterer bought 144 pineapples at Kshs 100 for every six pineapples. She sold some of them at Kshs 72 for every three and the rest at Kshs 60 for every two.
- If she made a 65% profit, calculate the number of pineapples sold at Kshs 72 for every three.

TOPIC 7:

GEOMETRY

PAST KCSE QUESTIONS ON THE TOPIC

1. A point B is on a bearing of 080° from a port A and at a distance of 95 km. A submarine is stationed at a port D, which is on a bearing of 200° from AM and a distance of 124 km from B.

A ship leaves B and moves directly southwards to an island P, which is on a bearing of 140° from A. The submarine at D on realizing that the ship was heading fro the island P, decides to head straight for the island to intercept the ship

Using a scale Of 1 cm to represent 10 km, make a scale drawing showing the relative positions of A, B, D, P.

Hence find

- (i) The distance from A to D
 - (ii) The bearing of the submarine from the ship was setting off from B
 - (iii) The bearing of the island P from D
 - (iv)The distance the submarine had to cover to reach the island P
2. Four towns R, T, K and G are such that T is 84 km directly to the north R, and K is on a bearing of 295° from R at a distance of 60 km. G is on a bearing of 340° from K and a distance of 30 km. Using a scale of 1 cm to represent 10 km, make an accurate scale drawing to show the relative positions of the town.

Find

(a) The distance and the bearing of T from K

(b) The distance and the bearing G from T

(c) The bearing of R from G

3. Two aeroplanes, S and T leave airports A at the same time. S flies on a bearing of 060° at 750 km/h while T flies on a bearing of 210° at 900 km/h .

(a) Using a suitable scale, draw a diagram to show the positions of the aeroplane after two hours.

(b) Use your diagram to determine

(i) The actual distance between the two aeroplanes

(ii) The bearing of T from S

(iii) The bearing of S from T

4. A point A is directly below a window. Another point B is 15 m from A and at the same horizontal level. From B angle of elevation of the top of the bottom of the window is 30° and the angle of elevation of the top of the window is 35° .

Calculate the vertical distance.

(a) From A to the bottom of the window

(b) From the bottom to top of the window

5. Find by calculation the sum of all the interior angles in the figure ABCDEFGHI

below

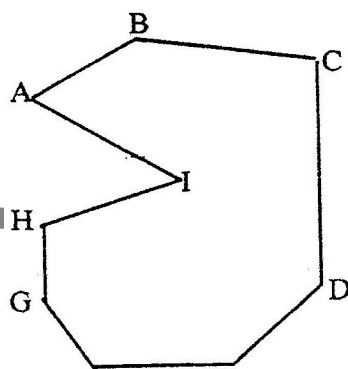

6. Shopping centers X, Y and Z are such that Y is 12 km south of X and Z is 15 km from X. Z is on a bearing of 330° from Y. Find the bearing of Z from X.

7. An electric pylon is 30m high. A point S on the top of the pylon is vertically above another point R on the ground. Points A and B are on the same horizontal ground as R. Point A due south of the pylon and the angle of elevation of S from A is 26° . Point B is due west of the pylon and the angle of elevation of S from B is 32°

Find the

- (a) Distance from A and B
- (b) Bearing of B from A

8. The figure below is a polygon in which $AB = CD = FA = 12\text{cm}$ $BC = EF = 4\text{cm}$ and $\angle BAF = \angle CDE = 120^\circ$. AD is a line of symmetry.

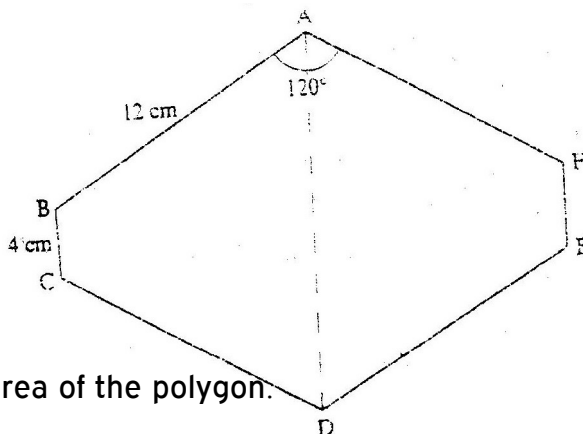

Find the area of the polygon.

9. The figure below shows a triangle ABC.

- a) Using a ruler and a pair of compasses, determine a point D on the line BC such that $BD:DC = 1:2$.
- b) Find the area of triangle ABD, given that $AB = AC$.
10. A boat at point X is 200 m to the south of point Y. The boat sails X to another point Z. Point Z is 200m on a bearing of 310° from X, Y and Z are on the same horizontal plane.
- (a) Calculate the bearing and the distance of Z from Y
- (b) W is the point on the path of the boat nearest to Y.
Calculate the distance WY
- (c) A vertical tower stands at point Y. The angle of point X from the top of the tower is 6° calculate the angle of elevation of the top of the tower from W.
11. The figure below shows a quadrilateral ABCD in which $AB = 8$ cm, $DC = 12$ cm, $\angle BAD = 45^\circ$, $\angle CBD = 90^\circ$ and $\angle BCD = 30^\circ$.

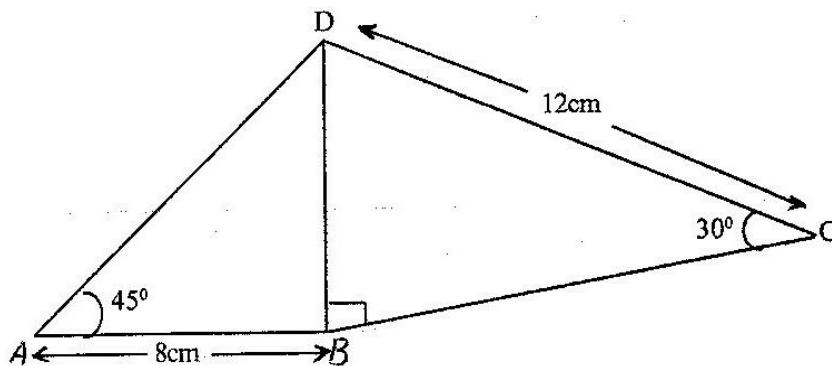

Find:

- (a) The length of BD

(b) The size of the angle A D B

12. In the figure below, ABCDE is a regular pentagon and ABF is an equilateral triangle

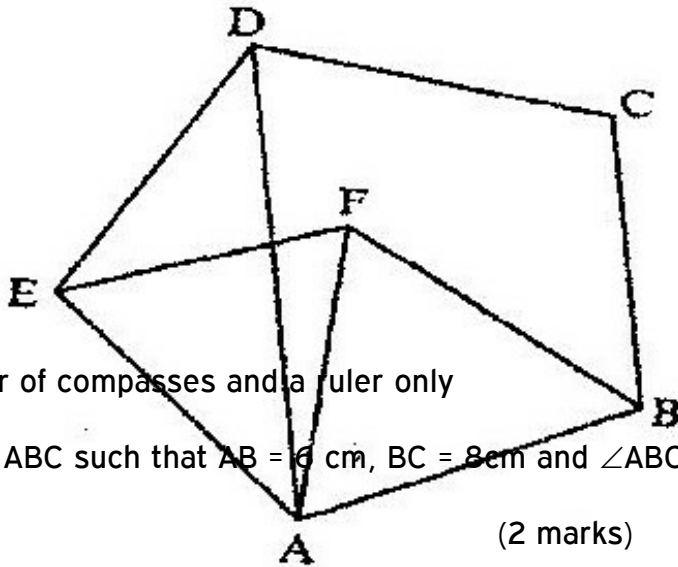

Find the size of

- a) $\angle ADE$
- b) $\angle AEF$
- c) $\angle DAF$

13. In this question use a pair of compasses and a ruler only

(a) construct triangle ABC such that $AB = 6\text{ cm}$, $BC = 8\text{ cm}$ and $\angle ABC = 135^\circ$

(2 marks)

(b) Construct the height of triangle ABC in a) above taking BC as the base

(1 mark)

14. The size of an interior angle of a regular polygon is $3x^\circ$ while its exterior angle is $(x - 20)^\circ$. Find the number of sides of the polygon

15. Points L and M are equidistant from another point K. The bearing of L from K is 330° . The bearing of M from K is 220° .

Calculate the bearing of M from L

16. Four points B, C, Q and D lie on the same plane point B is the 42 km due south-west of town Q. Point C is 50 km on a bearing of 56° from Q. Point D is equidistant from B, Q and C.

- (a) Using the scale 1 cm represents 10 km, construct a diagram showing the position of B, C, Q and D
- (b) Determine the
- (i) Distance between B and C
 - (ii) Bearing D from B
17. Two aeroplanes P and Q, leave an airport at the same time flies on a bearing of 240° at 900km/hr while Q flies due East at 750 km/hr
- (a) Using a scale of 1v cm drawing to show the positions of the aeroplanes after 40 minutes.
- (b) Use the scale drawing to find the distance between the two aeroplane after 40 minutes
- (c) Determine the bearing of
- (i) P from Q ans 254°
 - (ii) Q from P ans 74°
18. A port B is no a bearing of 080° from a port A and at a distance of 95 km. A submarine is stationed port D which is on a bearing of 200° from A, and a distance of 124 km from B.
- A ship leaves B and moves directly southwards to an island P, which is on a bearing of 140° from A. The submarine at D on realizing that the ship was heading for the island P decides to head straight for the island to intercept the ship.
- Using a scale of 1 cm to represent 10 km, make a scale drawing showing the

relative position of A, B D and P.

Hence find:

- (i) The distance from A and D
- (ii) The bearing of the submarine from the ship when the ship was setting off from B
- (iii) The bearing of the island P from D
- (iv) The distance the submarine had to cover to reach the island

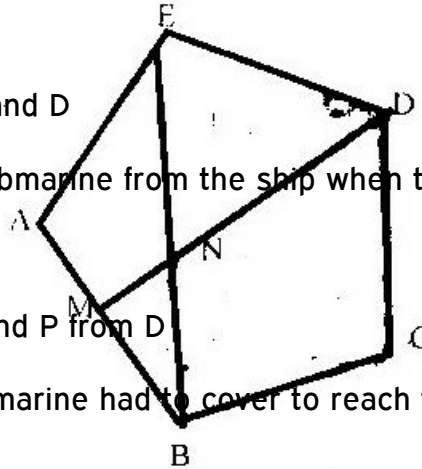

19. Four towns R, T, K and G are such that T is 84 km directly to the north R and K is on a bearing of 295° from R at a distance of 60 km. G is on a bearing of 340° from K and a distance of 30 km. Using a scale of 1 cm to represent 10 km, make an acute scale drawing to show the relative positions of the towns.

Find

- (a) The distance and bearing of T from K
 - (b) The bearing of R from G
20. In the figure below, ABCDE is a regular pentagon and M is the midpoint of AB. DM intersects EB at N. (T7)

Find the size of

- (a) $\angle BAE$

(b) \angle BED

(c) \angle BNM

21. Use a ruler and compasses in this question. Draw a parallelogram ABCD in which $AB = 8\text{cm}$, $BC = 6\text{ cm}$ and $\angle BAD = 75^\circ$. By construction, determine the perpendicular distance between AB and CD.
22. The interior angles of the hexagon are $2x^\circ$, $\frac{1}{2}x^\circ$, $x + 40^\circ$, 110° , 130° and 160° . Find the value of the smallest angle.
23. The size of an interior angle of a regular polygon is 156° . Find the number of sides of the polygon.

TOPIC 8:

COMMON SOLIDS

PAST KCSE QUESTIONS ON THE TOPIC

1. The figure below shows a net of a prism whose cross – section is an equilateral triangle.



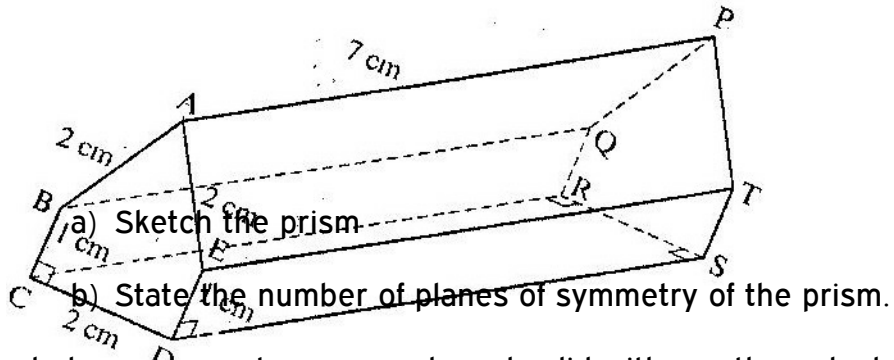

2. The figure below represents a square based solid with a path marked on it.

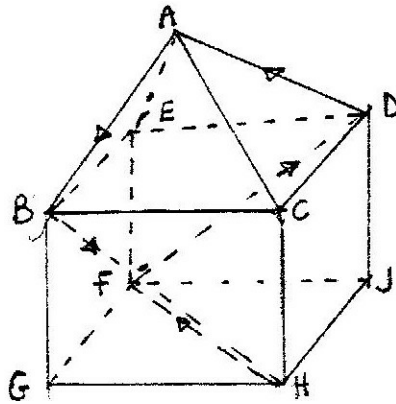

Sketch and label the net of the solid.

3. The figure below represents a prism of length 7 cm

$$AB = AE = CD = 2 \text{ cm and } BC - ED = 1 \text{ cm}$$

Draw the net of the prism

(3 marks)

4. The diagram below represents a right pyramid on a square base of side 3 cm. The

slant of the pyramid is 4 cm.

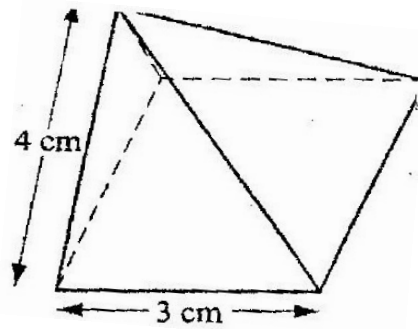

- (a) Draw a net of the pyramid (2 marks)
 - (b) On the net drawn, measure the height of a triangular face from the top of the Pyramid (1 mark)
- 5.
- (a) Draw a regular pentagon of side 4 cm (1 mark)
 - (b) On the diagram drawn, construct a circle which touches all the sides of the pentagon (2 marks)

6. The figure below shows a solid regular tetrapack of sides 6 cm

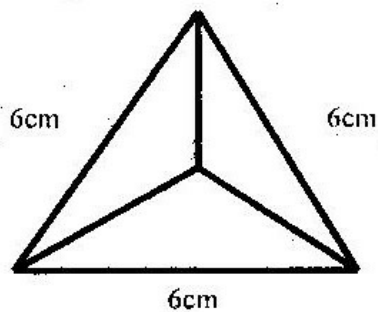

- (a) Draw a net of the solid
 - (b) Find the surface area of the solid
7. The figure below shows a solid made by pasting two equal regular tetrahedral

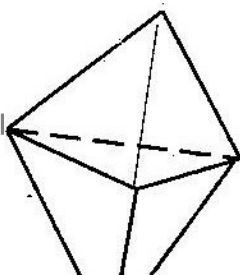

- (a) Draw a net of the solid
- (b) If each face is an equilateral triangle of side 5cm, find the surface area of the solid.

8. (a) Sketch the net of the prism shown below

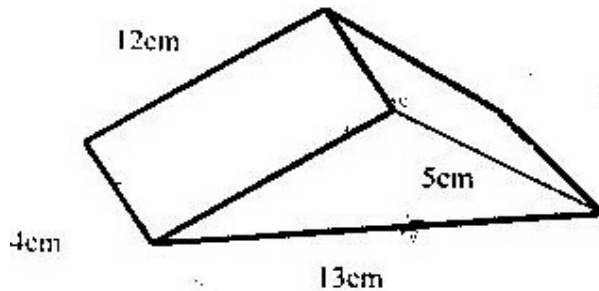

- (b) Find the surface area of the solid

FORM TWO

TOPIC 1

NUMBERS

PAST KCSE QUESTIONS ON THE TOPIC

1. Use logarithms to evaluate



$$3 \sqrt[3]{36.15 \times 0.02573}$$

1,938

2. Find the value of x which satisfies the equation.

$$16^{x^2} = 8^{4x-3}$$

3. Use logarithms to evaluate $\frac{(1934)^2 \times \sqrt{0.00324}}{436}$

436

4. Use logarithms to evaluate

$$55.9 \div (02621 \times 0.01177)^{1/5}$$

5. Simplify $2^x \times 5^{2x} \div 2^{-x}$

6. Use logarithms to evaluate

$$(3.256 \times 0.0536)^{1/3}$$

7. Solve for x in the equation

$$32^{(x-3)} \div 8^{(x-4)} = 64 \div 2^x$$

8. Solve for x in the equations $\frac{81^{2x} \times 27^x}{9x} = 729$

9x

9. Use reciprocal and square tables to evaluate to 4 significant figures, the expression:

$$\left(\frac{1}{24.56} \right) + 4 \cdot 346^2$$

10. Use logarithm tables, to evaluate

$$\left(\frac{0.032 \times 14.26}{0.006} \right)^{2/3}$$

0.006

11. Find the value of x in the following equation

$$49^{(x+1)} + 7^{(2x)} = 350$$

12. Use logarithms to evaluate

$$\frac{(0.07284)^2}{3\sqrt{0.06195}}$$

13. Find the value of m in the following equation

$$(1/27^m \times 81)^{-1} = 243$$

14. Given that $P = 3^y$ express the equation $3^{(2y-1)} + 2 \times 3^{(y-1)} = 1$ in terms of P hence or otherwise find the value of y in the equation $3^{(2y-1)} + 2 \times 3^{(y-1)} = 1$

15. Use logarithms to evaluate $55.9 \div (0.2621 \times 0.01177)^{1/5}$

16. Use logarithms to evaluate

$$\frac{\left(\frac{6.79 \times 0.3911}{\log 5} \right)^{3/4}}$$

17. Use logarithms to evaluate

$$\frac{\sqrt[3]{1.23 \times 0.0089}}{79.54}$$

18. Solve for x in the equation

$$X = \frac{0.0056}{2}$$

$$1.38 \times 27.42$$

TOPIC 2:

EQUATIONS OF LINES

PAST KCSE QUESTIONS ON THE TOPIC

- The coordinates of the points P and Q are (1, -2) and (4, 10) respectively.
A point T divides the line PQ in the ratio 2: 1
 - Determine the coordinates of T
 - Find the gradient of a line perpendicular to PQ
 - Hence determine the equation of the line perpendicular PQ and passing through T
 - If the line meets the y- axis at R, calculate the distance TR, to three significant figures
- A line L_1 passes through point (1, 2) and has a gradient of 5. Another line L_2 , is perpendicular to L_1 and meets it at a point where $x = 4$. Find the equation for L_2 in the form of $y = mx + c$
- P (5, -4) and Q (-1, 2) are points on a straight line. Find the equation of the perpendicular bisector of PQ: giving the answer in the form $y = mx+c$.
- On the diagram below, the line whose equation is $7y - 3x + 30 = 0$ passes through the points A and B. Point A on the x-axis while point B is equidistant from x and y axes.

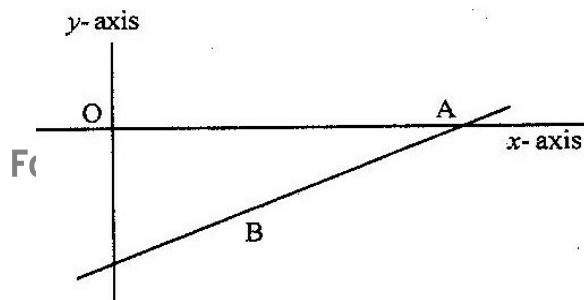

Calculate the co-ordinates of the points A and B

5. A line with gradient of -3 passes through the points $(3, k)$ and $(k, 8)$. Find the value of k and hence express the equation of the line in the form $ax + by = c$, where a , b , and c are constants.
6. Find the equation of a straight line which is equidistant from the points $(2, 3)$ and $(6, 1)$, expressing it in the form $ax + by = c$ where a , b and c are constants.
7. The equation of a line $-\frac{3}{5}x + 3y = 6$. Find the:
 - (a) Gradient of the line (1
mk)
 - (b) Equation of a line passing through point $(1, 2)$ and perpendicular to the given line b
8. Find the equation of the perpendicular to the line $x + 2y = 4$ and passes through point $(2, 1)$
9. Find the equation of the line which passes through the points $P(3, 7)$ and $Q(6, 1)$
10. Find the equation of the line whose x - intercepts is -2 and y - intercepts is 5
11. Find the gradient and y - intercept of the line whose equation is $4x - 3y - 9 = 0$

TOPIC 3

TRANSFORMATIONS

PAST KCSE QUESTIONS ON THE TOPIC

1. A translation maps a point $(1, 2)$ onto $(-2, 2)$. What would be the coordinates of the object whose image is $(-3, -3)$ under the same translation?

2. Use binomial expression to evaluate $(0.96)^5$ correct to 4 significant figures

11. In the figure below triangle ABO represents a part of a school badge. The badge has as symmetry of order 4 about O. Complete the figures to show the badge.

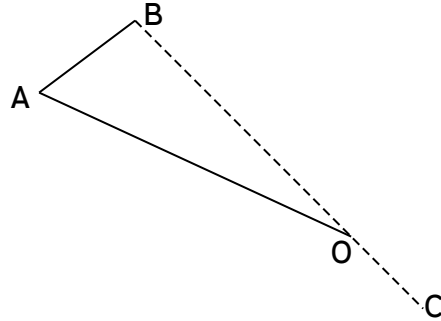

3. A point $(-5, 4)$ is mapped onto $(-1, -1)$ by a translation. Find the image of $(-4, 5)$ under the same translation.

4. A triangle is formed by the coordinates A $(2, 1)$ B $(4, 1)$ and C $(1, 6)$. It is rotated clockwise through 90° about the origin. Find the coordinates of this image.

5. The diagram on the grid provided below shows a trapezium ABCD

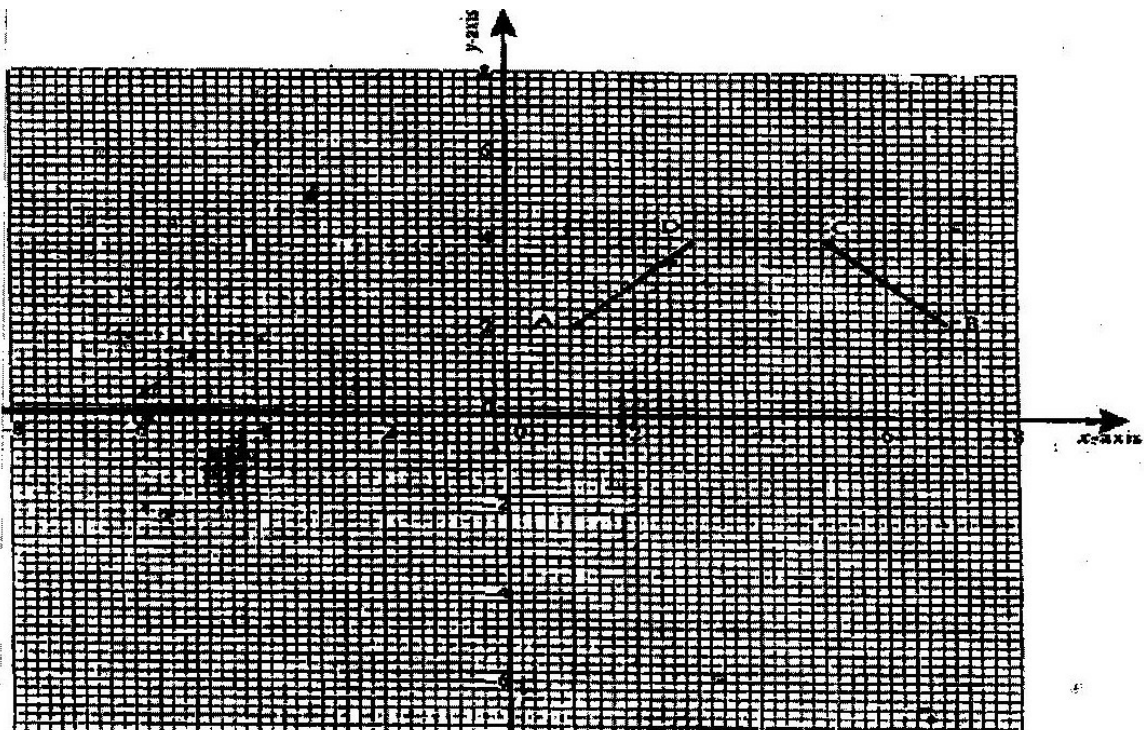

On the same grid

- (a) (i) Draw the image $A'B'C'D'$ of $ABCD$ under a rotation of 90° clockwise about the origin .
- (ii) Draw the image of $A''B''C''D''$ of $A'B'C'D'$ under a reflection in line $y = x$. State coordinates of $A''B''C''D''$.
- (b) $A''B''C''D''$ is the image of $A''B''C''D''$ under the reflection in the line $x=0$. Draw the image $A''B''C''D''$ and state its coordinates.
- (c) Describe a single transformation that maps $A''B''C''D''$ onto $ABCD$.

6. A translation maps a point $P(3,2)$ onto $P'(5,4)$

- (a) Determine the translation vector
- (b) A point Q' is the image of the point $Q(, 5)$ under the same translation. Find the length of $P'Q$ leaving the answer in surd form.

7. Two points P and Q have coordinates $(-2, 3)$ and $(1, 3)$ respectively. A translation map point P to $P'(10, 10)$

- (a) Find the coordinates of Q' the image of Q under the translation (1 mk)
- (b) The position vector of P and Q in (a) above are p and q respectively given that $mp - nq = \begin{pmatrix} -12 \\ \end{pmatrix}$

9 Find the value of m and n (3mks)

8. on the Cartesian plane below, triangle PQR has vertices $P(2, 3)$, $Q(1, 2)$ and $R(4, 1)$ while triangle $P''Q''R''$ has vertices $P''(-2, 3)$, $Q''(-1, 2)$ and $R''(-4, 1)$

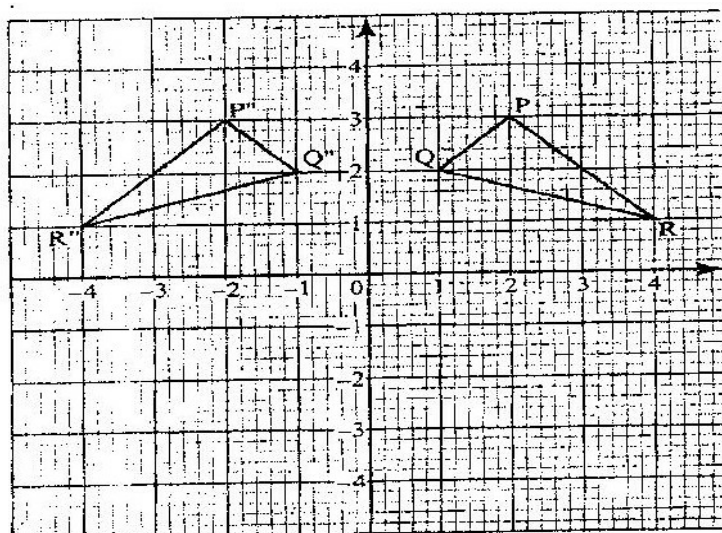

- Describe fully a single transformation which maps triangle PQR onto triangle P''Q''R''
- On the same plane, draw triangle P'Q'R', the image of triangle PQR, under reflection in line $y = -x$
- Describe fully a single transformation which maps triangle P'Q'R' onto triangle P''Q''R''
- Draw triangle P'''Q'''R''' such that it can be mapped onto triangle PQR by a positive quarter turn about (0, 0)
- State all pairs of triangle that are oppositely congruent

TOPIC 4:

MEASUREMENT**PAST KCSE QUESTIONS ON THE TOPIC**

1. A solid cone of height 12 cm and radius 9 cm is recast into a solid sphere. Calculate the surface area of the sphere.
2. A circular path of width 14 metres surrounds a field of diameter 70 metres. The path is to be carpeted and the field is to have a concrete slab with an exception of four rectangular holes each measuring 4 metres by 3 metres.

A contractor estimated the cost of carpeting the path at Kshs. 300 per square metre and the cost of putting the concrete slab at Kshs 400 per square metre. He then made a quotation which was 15% more than the total estimate. After completing the job, he realized that 20% of the quotation was not spent.

- (a) How much money was not spent?
 - (b) What was the actual cost of the contract?
3. In the figure below BAD and CBD are right angled triangles.

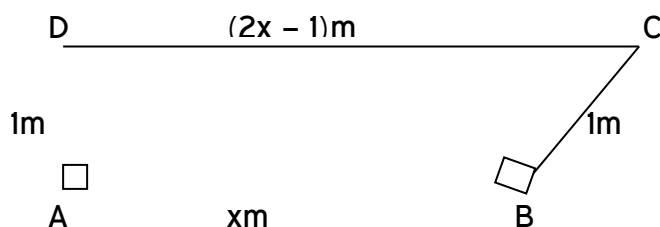

Find the length of AB.

4. A cylinder of radius 14 cm contains water. A metal solid cone of base radius 7 cm and height 18 cm is submerged into the water. Find the change in height of the water level in the cylinder.
5. A cylindrical container of radius 15 cm has some water in it. When a solid is

submerged into the water, the water level rises by 1.2 cm.

(a) Find, the volume of the water displaced by the solid leaving your answer in terms of π

(b) If the solid is a circular cone of height 9 cm, calculate the radius of the cone to 2 decimal places.

6. A balloon, in the form of a sphere of radius 2 cm, is blown up so that the volume increases by 237.5%. Determine the new volume of balloon in terms of π

A girl wanted to make a rectangular octagon of side 14 cm. She made it from a square piece of a card of size y cm by cutting off four isosceles triangles whose equal sides were x cm each, as shown below.

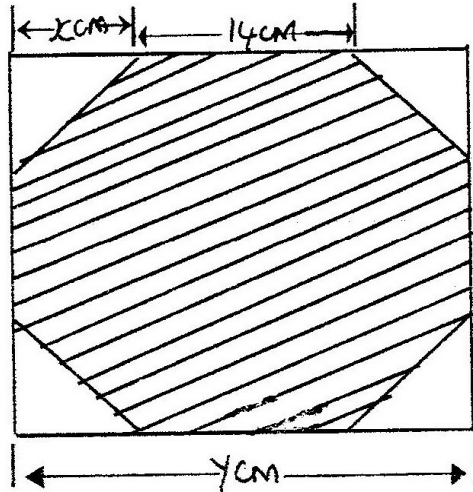

- (a) Write down an expression for the octagon in terms of x and y
 - (b) Find the value of x
 - (c) Find the area of the octagon
7. A pyramid VABCD has a rectangular horizontal base ABCD with $AB = 12$ cm and $BC = 9$ cm. The vertex V is vertically above A and $VA = 6$ cm. Calculate the volume of the pyramid.
8. A solid made up of a conical frustrum and a hemisphere top as shown in the figure below. The dimensions are as indicated in the figure.

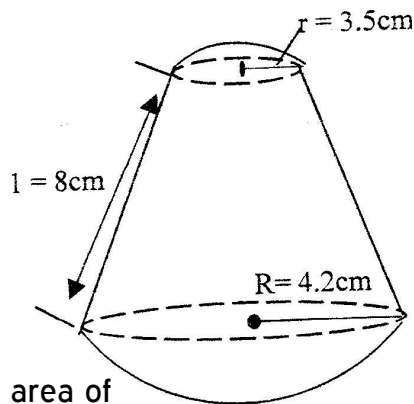

- (a) Find the area of

- (i) The circular base
 - (ii) The curved surface of the frustrum
 - (iii) The hemisphere surface
- (b) A similar solid has a total area of 81.51 cm^2 . Determine the radius of its base.

9. Two sides of triangles are 5 cm each and the angle between them is 120° . Calculate the area of the triangle.

10. The figure below represents a kite ABCD, $AB = AD = 15 \text{ cm}$. The diagonals BD and AC intersect at O. $AC = 30 \text{ cm}$ and $AO = 12 \text{ cm}$.

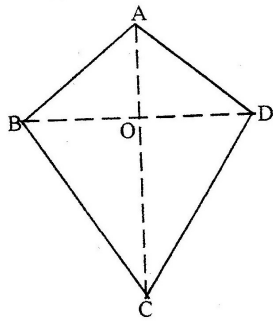

Find the area of the kite

11. The diagram below represents a solid made up of a hemisphere mounted on a cone. The radius of the hemisphere are each 6 cm and the height of the cone is 9 cm.

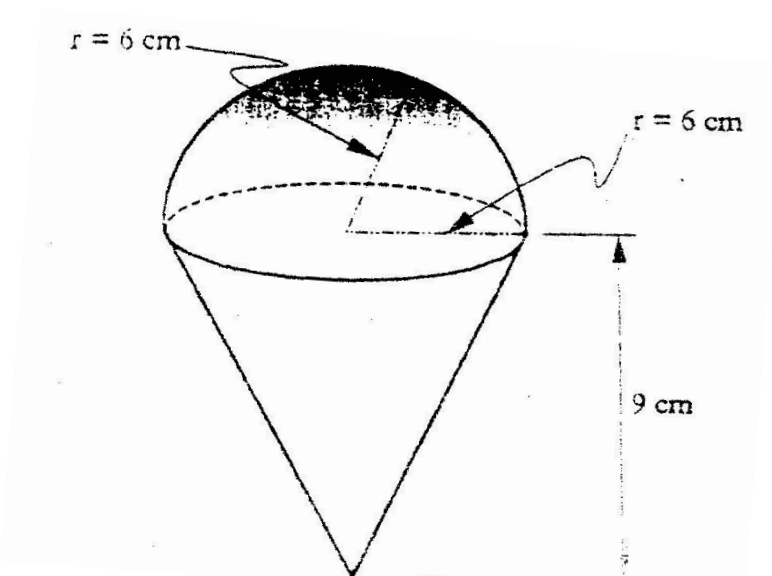

Calculate the volume of the solid take $\pi = \frac{22}{7}$

12. The internal and external diameters of a circular ring are 6 cm and 8cm respectively.
Find the volume of the ring if its thickness is 2 millimeters.

2003

13. A wire of length 21 cm is bent to form the shape down in the figure below, ABCD is a rectangle and AEB is an equilateral triangle. (2mks)

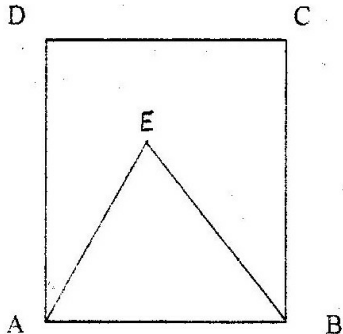

If the length of AD of the rectangle is $1\frac{1}{2}$ times its width, calculate the width of the rectangle.

14. The length of a hollow cylindrical pipe is 6 metres. Its external diameter is 11 cm and has a thickness of 1 cm. Calculate the volume in cm^3 of the material used to make the pipe. Take π as 3.142.

15. The figure below represents a hexagon of side 5 cm and 20 cm height

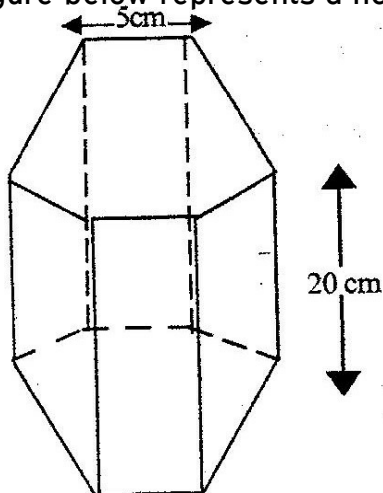

Find the volume of the prism.

16. A cylindrical piece of wood of radius 4.2 cm and length 150 cm is cut length into two equal pieces.

Calculate the surface area of one piece

(Take π as $\frac{22}{7}$)

17. The figure below is a model representing a storage container. The model whose total height is 15 cm is made up of a conical top, a hemispherical bottom and the middle part is cylindrical. The radius of the base of the cone and that of the hemisphere are each 3 cm. The height of the cylindrical part is 8 cm.

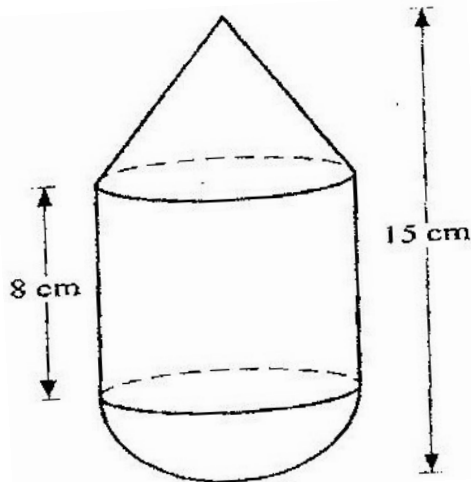

- (a) Calculate the external surface area of the model
 - (b) The actual storage container has a total height of 6 metres. The outside of the actual storage container is to be painted. Calculate the amount of paint required if an area of 20m^2 requires 0.75 litres of the paint.
18. A garden measures 10m long and 8 m wide. A path of uniform width is made all round the garden. The total area of the garden and the paths is 168 m^2 .
- (a) Find the width of the path
 - (b) The path is to be covered with square concrete slabs. Each corner of the path is

covered with a slab whose side is equal to the width of the path.

The rest of the path is covered with slabs of side 50 cm. The cost of making each corner slab is Kshs 600 while the cost of making each smaller slab is Kshs 50.

Calculate

- (i) The number of smaller slabs used
- (ii) The total cost of the slabs used to cover the whole path

19. A cylindrical solid of radius 5 cm and length 12 cm floats lengthwise in water to a depth of 2.5 cm as shown in the figure below.

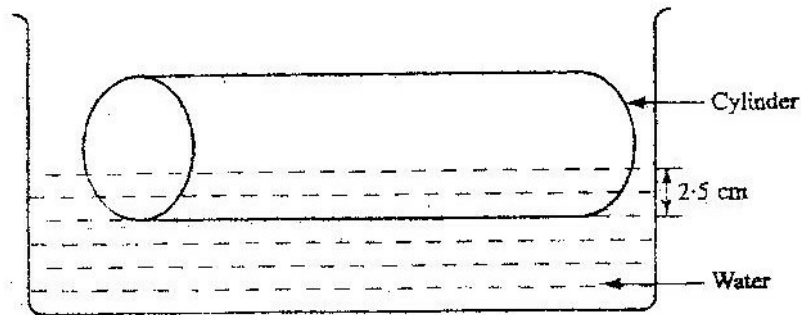

Calculate the area of the curved surface of the solid in contact with water, correct to 4 significant figures

20. Two cylindrical containers are similar. The larger one has internal cross-section area of 45 cm^2 and can hold 0.945 litres of liquid when full. The smaller container has internal cross-section area of 20 cm^2

- (a) Calculate the capacity of the smaller container
- (b) The larger container is filled with juice to a height of 13 cm. Juice is then drawn from it and emptied into the smaller container until the depths of the juice in both containers are equal.

Calculate the depths of juice in each container.

- (c) On fifth of the juice in the larger container in part (b) above is further drawn and

emptied into the smaller container. Find the difference in the depths of the juice in the two containers.

22. A metal bar is a hexagonal prism whose length is 30 cm, the cross section is a regular hexagon with each side of length 6 cm

Find

- (i) The area of the hexagonal face (3mks)
(ii) The volume of the metal bar (2mks)

23. A cylindrical water tank of diameter 7 metres and height 2.8 metres

- (a) Find the capacity of the water tank in litres
(b) Six members of family use 15 litres each per day. Each day 80 litres are used for cooking and washing and a further 60 litres are wasted.

Find the number of complete days a full tank would last the family (2mks)

- (c) Two members of the family were absent for 90 days. During the 90 days wastage was reduced by 20% but cooking and washing remained the same.
Calculate the number of days a full tank would now last the family

24. Pieces of soap are packed in a cuboid container measuring 36 cm by 24 cm by 18 cm. Each piece of soap is similar to the container. If the linear scale factor between the container and the soap is $\frac{1}{6}$ find the volume of each piece of soap.

25. A pyramid of height 10cm stands, on a square base ABCD of side 6 cm.

- (a) Draw a sketch of the pyramid
(b) Calculate the perpendicular distance from the vertex to the side AB.

TOPIC 5

QUADRATIC EQUATIONS

PAST KCSE QUESTIONS ON THE TOPIC

1. Simplify

$$\frac{2x - 2}{6x^2 - x - 12} \div \frac{x - 1}{2x - 3}$$

2. Solve the simultaneous equations

$$2x - y = 3$$

$$x^2 - xy = -4$$

3. Find the value of x in the following equations:

$$49^{x+1} + 7^{2x} = 350$$

4. Simplify completely

$$\frac{3x^2 - 1 - 2x + 1}{x^2 - 1} \cdot \frac{1}{x + 1}$$

$$x^2 - 1 \quad x + 1$$

5. Factorize completely $3x^2 - 2xy - y^2$

6. Factorize $a^2 - b^2$

Hence find the exact value of $2557^2 - 2547^2$

7. If $x^2 + y^2 = 29$ and $x + y = 3$

(a) Determine the values of

(i) $x^2 + 2xy + y^2$

(ii) $2xy$

(iii) $x^2 - 2xy + y^2$

(iv) $x - y$

(b) Find the value of x and y

8. Simplify the expression $\frac{3a^2 + 4ab + b^2}{4a^2 + 3ab - b^2}$

$$4a^2 + 3ab - b^2$$

9. (a) Write an expression in terms of x and y for the total value of a two digit number having x as the tens digit and y as the units digit.

b) The number in (a) above is such that three times the sum of its digits is less than the value of the number by 8. When the digits are reversed the value of the number increases by 9. Find the number xy .

10. Simplify the expression $\frac{2a^2 - 3ab - 2b^2}{4a^2 - b^2}$

$$4a^2 - b^2$$

11. Simplify the expression $\frac{9t^2 - 25a^2}{6t^2 + 19at + 15a^2}$

$$6t^2 + 19at + 15a^2$$

12. Simplify

$$\frac{p^2 + 2pq + q^2}{p^3 - pq^2 + p^2q - q^3}$$

$$p^3 - pq^2 + p^2q - q^3$$

13. Expand the expression $(x^2 - y^2)(x^2 + y^2)(x^4 - y^4)$

14. The sum of two numbers x and y is 40. Write down an expression, in terms of x , for the sum of the squares of the two numbers.

Hence determine the minimum value of $x^2 + y^2$

15. Simplify the expression $\frac{15a^2b - 10ab^2}{-5ab + 2b^2}$

$$-5ab + 2b^2$$

16. Four farmers took their goats to the market Mohamed had two more goats than Ali Koech had 3 times as many goats as Mohamed. Whereas Odupoy had 10 goats less than both Mohamed and Koech.

- (i) Write a simplified algebraic expression with one variable. Representing the total number of goats
- (ii) Three butchers bought all the goats and shared them equally. If each butcher got 17 goats. How many did Odupoy sell to the butchers?

17. Find the value of x which satisfies the equation $16^{2x} = 8^{4x-3}$

18. Mary has 21 coins whose total value is Kshs 72. There are twice as many five shillings coins as there are ten shillings coins. The rest one shilling coins. Find the number of ten shilling coins that Mary has.

19. Simplify the expression

$$\frac{x-1}{x} - \frac{2x+1}{3x}$$

Hence solve the equation $\frac{x-1}{x} - \frac{2x+1}{3x} = \frac{2}{3}$

$$x \qquad \qquad \qquad 3x \qquad \qquad \qquad 3$$

20. Given that $P = 3^y$ express the equation

$$3^{2y-1} + 2 \times 3^{y-1} = 1$$
 in terms of P.

Hence or otherwise find the value of y in the equation $3^{2y-1} + 2 \times 3^{y-1} = 1$

21. Simplify the expression

$$\frac{4x^2 - y^2}{2x^2 - 7xy + 3y}$$

22. Three years ago Juma was three times as old as Ali. In two years time the sum of

their ages will be 62. Determine their present ages.

23. Simplify

$$\frac{x-2}{x+2} - \frac{2x+20}{x^2-4}$$

$$\frac{x-2}{x+2} - \frac{2x+20}{x^2-4}$$

24. If the expression $25y^2 - 70y + d$ is a perfect square, where d is a constant, find the value of d

TOPIC 6

INEQUALITIES

PAST KCSE QUESTIONS ON THE TOPIC

1. Find the range of x if $2 \leq 3 - x < 5$

2. Find all the integral values of x which satisfy the inequalities:

$$2(2-x) < 4x - 9 < x + 11$$

3. Solve the inequality and show the solution

$$3 - 2x < x \leq \frac{2x+5}{3} \text{ on the number line}$$

3

4. Solve the inequality $\frac{x-3}{4} + \frac{x-5}{6} \leq \frac{4x+6}{8} - 1$

$$\frac{x-3}{4} + \frac{x-5}{6} \leq \frac{4x+6}{8} - 1$$

5. A family is planning a touring holiday, during which time (x days) will be spent walking and the rest of the time (y days) in traveling by bus. Each day they can walk 30 km or travel 80 km by bus and they wish to travel at least 600 km altogether.

The holiday must not last more than 14 days. Each day walking will cost Kshs.

200 and each day traveling by bus will cost Kshs. 1400. The holiday must not

cost more than Kshs 9800

- (a) Write down all the inequalities in x and y based on the above facts
- (b) Represent the inequalities graphically
- (c) Use the graph to determine the integral values of x and y which give
 - (i) The cheapest holiday
 - (ii) The longest distance traveled

TOPIC 7

CIRCLES

PAST KCSE QUESTIONS ON THE TOPIC

1. In the figure below $CP = CQ$ and $\angle CQP = 160^\circ$. If $ABCD$ is a cyclic quadrilateral, find $\angle BAD$.

2. In the figure below AOC is a diameter of the circle centre O ; $AB = BC$ and $\angle ACD = 25^\circ$, EBF is a tangent to the circle at B . G is a point on the minor arc CD .

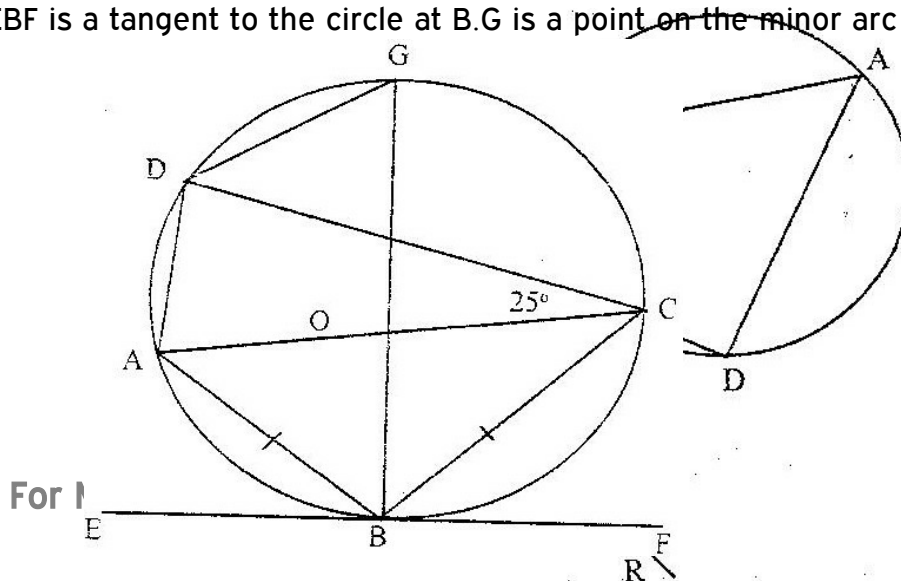

For 1

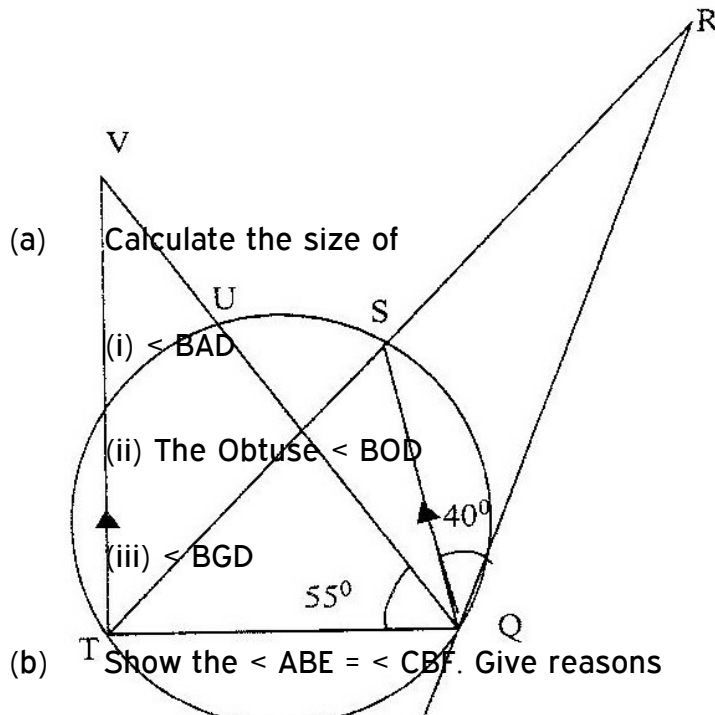

3. In the figure below PQR is the tangent to circle at Q. TS is a diameter and TSR and QUV are straight lines. QS is parallel to TV. Angles SQR = 40° and angle TQV = 55°

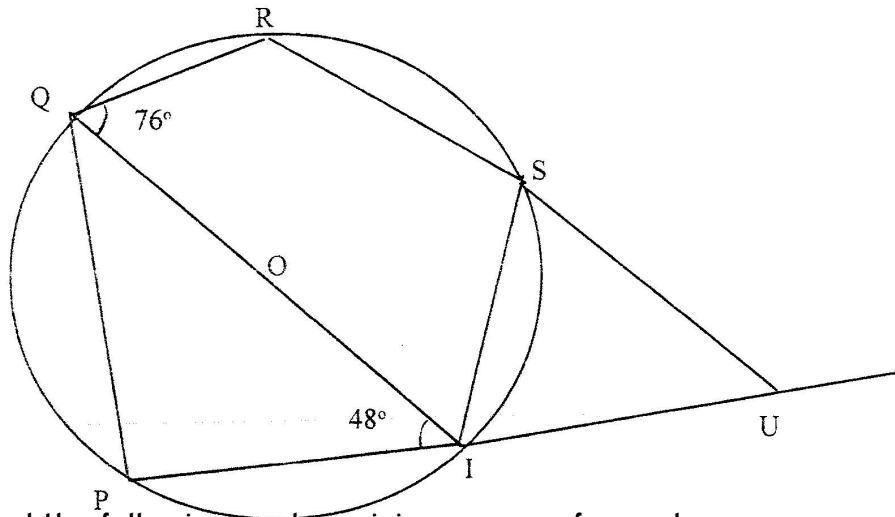

Find the following angles, giving reasons for each answer

- (a) QST
- (b) QRS
- (c) QVT
- (d) UTV

4. In the figure below, QOT is a diameter. $\angle QTR = 48^\circ$, $\angle TQR = 76^\circ$ and $\angle SRT = 37^\circ$

Calculate

- (a) $\angle RST$
- (b) $\angle SUT$
- (c) Obtuse $\angle ROT$

5. In the figure below, points O and P are centers of intersecting circles ABD and BCD respectively. Line ABE is a tangent to circle BCD at B. Angle BCD = 42°

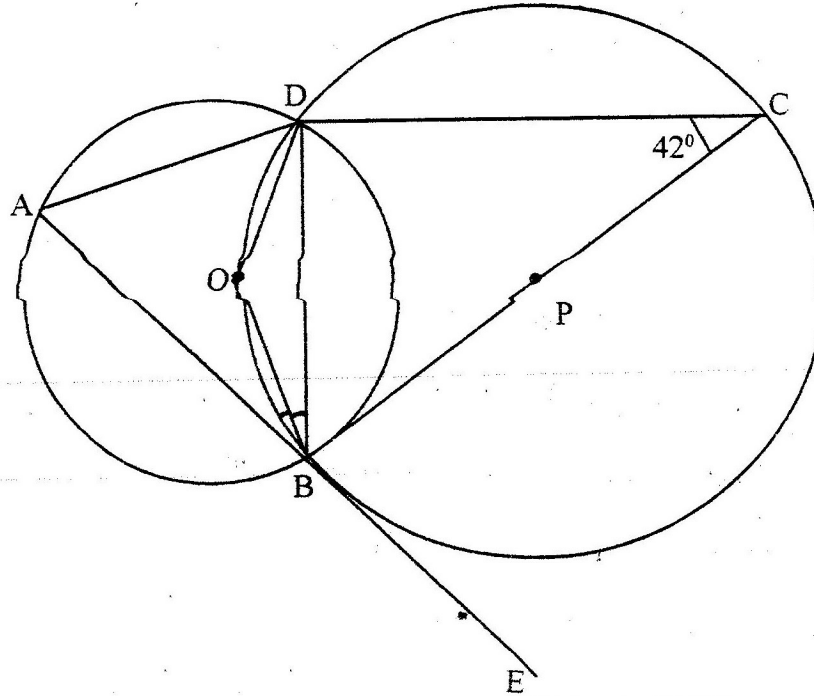

- (a) Stating reasons, determine the size of
- $\angle CBD$
 - Reflex $\angle BOD$
- (b) Show that $\triangle ABD$ is isosceles
6. The diagram below shows a circle ABCDE. The line FEG is a tangent to the circle at point E. Line DE is parallel to CG, $\angle DEC = 28^\circ$ and $\angle AGE = 32^\circ$

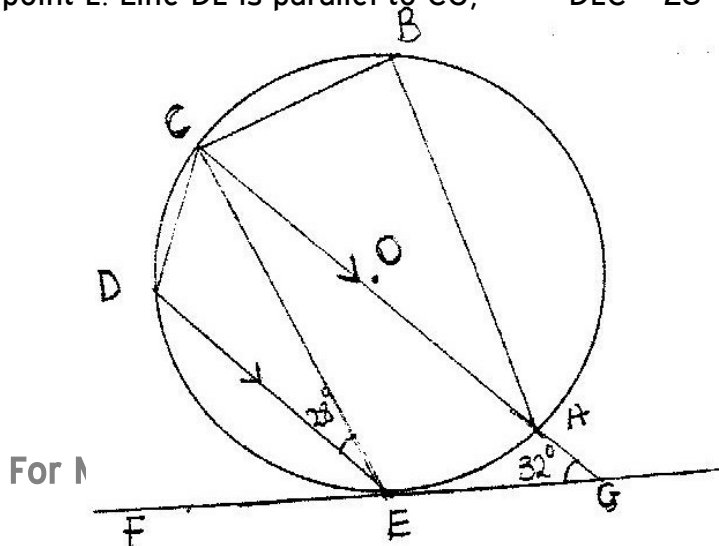

For M

Calculate:

- (a) $\angle AEG$
- (b) $\angle ABC$

7. In the figure below R, T and S are points on a circle centre O PQ is a tangent to the circle at T. POR is a straight line and $\angle QPR = 20^\circ$

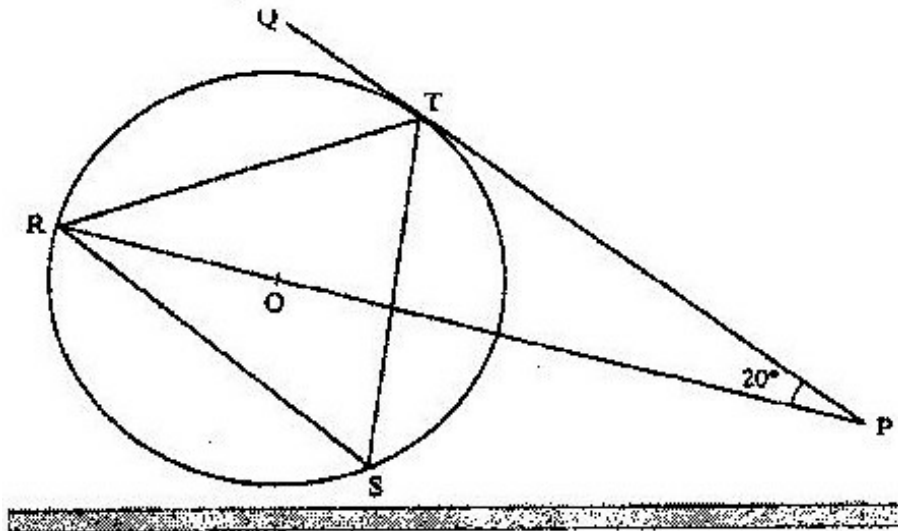

Find the size of $\angle RST$

8. The figure below shows a circle centre O and a point Q which is outside the circle

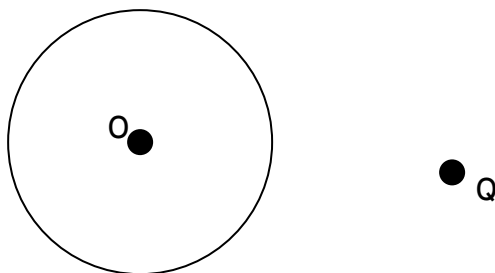

Using a ruler and a pair of compasses, only locate a point on the circle such that angle OPQ = 90°

TOPIC 8

LINEAR MOTION

PAST KCSE QUESTION ON THE TOPIC

1. Two towns P and Q are 400 km apart. A bus left P for Q. It stopped at Q for one hour and then started the return journey to P. One hour after the departure of the bus from P, a trailer also heading for Q left P. The trailer met the returning bus $\frac{3}{4}$ of the way from P to Q. They met t hours after the departure of the bus from P.
 - (a) Express the average speed of the trailer in terms of t
 - (b) Find the ratio of the speed of the bus so that of the trailer.
2. The athletes in an 800 metres race take 104 seconds and 108 seconds respectively to complete the race. Assuming each athlete is running at a constant speed. Calculate the distance between them when the faster athlete is at the finishing line.
3. A and B are towns 360 km apart. An express bus departs from A at 8 am and maintains an average speed of 90 km/h between A and B. Another bus starts from B also at 8 am and moves towards A making four stops at four equally spaced points between B and A. Each stop is of duration 5 minutes and the average speed between any two spots is 60 km/h. Calculate distance between the two buses at 10 am.
4. Two towns A and B are 220 km apart. A bus left town A at 11.00 am and traveled towards B at 60 km/h. At the same time, a matatu left town B for town A and traveled at 80 km/h. The matatu stopped for a total of 45 minutes on the way before meeting the bus. Calculate the distance covered by the bus before

meeting the matatu.

5. A bus travels from Nairobi to Kakamega and back. The average speed from Nairobi to Kakamega is 80 km/hr while that from Kakamega to Nairobi is 50 km/hr, the fuel consumption is 0.35 litres per kilometer and at 80 km/h, the consumption is 0.3 litres per kilometer .Find
- Total fuel consumption for the round trip
 - Average fuel consumption per hour for the round trip.
6. The distance between towns M and N is 280 km. A car and a lorry travel from M to N. The average speed of the lorry is 20 km/h less than that of the car. The lorry takes 1h 10 min more than the car to travel from M and N.
- If the speed of the lorry is x km/h, find x (5mks)
 - The lorry left town M at 8: 15 a.m. The car left town M and overtook the lorry at 12.15 p.m. Calculate the time the car left town M.
7. A bus left Mombasa and traveled towards Nairobi at an average speed of 60 km/hr. after $2\frac{1}{2}$ hours; a car left Mombasa and traveled along the same road at an average speed of 100 km/ hr. If the distance between Mombasa and Nairobi is 500 km, Determine
- The distance of the bus from Nairobi when the car took off (2mks)
 - The distance the car traveled to catch up with the bus
 - Immediately the car caught up with the bus
 - The car stopped for 25 minutes. Find the new average speed at which the car traveled in order to reach Nairobi at the same time as the bus.
8. A rally car traveled for 2 hours 40 minutes at an average speed of 120 km/h. The car consumes an average of 1 litre of fuel for every 4 kilometers.

A litre of the fuel costs Kshs 59

Calculate the amount of money spent on fuel

9. A passenger notices that she had forgotten her bag in a bus 12 minutes after the bus had left. To catch up with the bus she immediately took a taxi which traveled at 95 km/hr. The bus maintained an average speed of 75 km/ hr. determine
- (a) The distance covered by the bus in 12 minutes
 - (b) The distance covered by the taxi to catch up with the bus
10. The athletes in an 800 metre race take 104 seconds and 108 seconds respectively to complete the race. Assuming each athlete is running at a constant speed. Calculate the distance between them when the faster athlete is at the finishing line.
11. Mwangi and Otieno live 40 km apart. Mwangi starts from his home at 7.30 am and cycles towards Otieno's house at 16 km/ h Otieno starts from his home at 8.00 and cycles at 8 km/h towards Mwangi at what time do they meet?
12. A train moving at an average speed of 72 km/h takes 15 seconds to completely cross a bridge that is 80m long.
- (a) Express 72 km/h in metres per second
 - (b) Find the length of the train in metres

FORM 3

TOPIC 1

QUADRATIC EXPRESSIONS AND EQUATIONS

PAST KCSE QUESTIONS ON THE TOPIC

1. The table shows the height metres of an object thrown vertically upwards varies with the time t seconds

The relationship between s and t is represented by the equations $s = at^2 + bt + 10$ where a and b are constants.

t	0	1	2	3	4	5	6	7	8	9	10
s		45.1									

- (a) (i) Using the information in the table, determine the values of a and b

(2 marks)

- (ii) Complete the table (1 mark)

- (b)(i) Draw a graph to represent the relationship between s and t (3 marks)

- (ii) Using the graph determine the velocity of the object when $t = 5$

seconds

2. (a) Construct a table of value for the function $y = x^2 - x - 6$ for $-3 \leq x \leq 4$

- (b) On the graph paper draw the graph of the function

$$Y = x^2 - x - 6 \text{ for } -3 \leq x \leq 4$$

- (c) By drawing a suitable line on the same grid estimate the roots of the

$$\text{equation } x^2 + 2x - 2 = 0$$

3. (a) Draw the graph of $y = 6 + x - x^2$, taking integral value of x in $-4 \leq x \leq 5$. (The grid is provided. Using the same axes draw the graph of $y = 2 - 2x$

- (b) From your graphs, find the values of X which satisfy the simultaneous equations $y = 6 + x - x^2$

$$y = 2 - 2x$$

- (c) Write down and simplify a quadratic equation which is satisfied by the values of x where the two graphs intersect.

4. (a) Complete the following table for the equation $y = x^3 - 5x^2 + 2x + 9$

x	-2	-1.5	-1	0	1	2	3	4	5
x^2		-3.4	-1	0	1		27	64	125
$-5x^2$	-20	-11.3	-5	0	-1	-20	-45		
$2x$	-4	-3		0	2	4	6	8	10
9	9	9	9	9	9	9	9	9	99
		-8.7			9	7		-3	

(b) On the grid provided draw the graph of $y = x^3 - 5x^2 + 2x + 9$ for $-2 \leq x \leq 5$

(c) Using the graph estimate the root of the equation $x^3 - 5x^2 + 2x + 9 = 0$

between $x =$

2 and $x = 3$

(d) Using the same axes draw the graph of $y = 4 - 4x$ and estimate a solution

to the

equation $x^2 - 5x^2 + 6x + 5 = 0$

5. (a) Complete the table below, for function $y = 2x^2 + 4x - 3$

x	-4	-3	-2	-1	0	1	2
$2x^2$	32		8	2	0	2	
$4x - 3$			-11		-3		5
y			-3			3	13

(b) On the grid provided, draw the graph of the function $y = 2x^2 + 4x - 3$ for $-4 \leq x \leq 2$ and use the graph to estimate the roots of the equation $2x^2 + 4x -$

3 = 0 to 1 decimal place.

(2mks)

- (c) In order to solve graphically the equation $2x^2 + x - 5 = 0$, a straight line must be drawn to intersect the curve $y = 2x^2 + 4x - 3$. Determine the equation of this straight line, draw the straight line hence obtain the roots of $2x^2 + x - 5$ to 1 decimal place.

6. (a) (i) Complete the table below for the function $y = x^3 + x^2 - 2x$ (2mks)

x	-3	-2.5	-2	-1.5	-1	-0.5	0	0.5	1	2	2.5
x^3		15.63				-0.13			1		
x^2			4					0.25			6.25
$-2x$						1			-2		
y				1.87				0.63			16.88

- (ii) On the grid provided, draw the graph of $y = x^3 + x^2 - 2x$ for the values of x in the interval $-3 \leq x \leq 2.5$
- (iii) State the range of negative values of x for which y is also negative
- (b) Find the coordinates of two points on the curve other than (0, 0) at which x- coordinate and y- coordinate are equal

7. The table shows some corresponding values of x and y for the curve represented by $Y = \frac{1}{4} x^3 - 2$

X	-3	-2	-1	0	1	2	3
Y	-8.8	-4	-2.3	-2	-1.8	0	4.8

On the grid provided below, draw the graph of $y = \frac{1}{4}x^2 - 2$ for $-3 \leq x \leq 3$. Use the graph to estimate the value of x when $y = 2$

8. A retailer planned to buy some computers from a wholesaler for a total of Kshs 1,800,000. Before the retailer could buy the computers the price per unit was reduced by Kshs 4,000. This reduction in price enabled the retailer to buy five more computers using the same amount of money as originally planned.
- (a) Determine the number of computers the retailer bought
 - (b) Two of the computers purchased got damaged while in store, the rest were sold and the retailer made a 15% profit. Calculate the profit made by the retailer on each computer sold

9. The figure below is a sketch of the graph of the quadratic function $y = k(x+1)(x-2)$

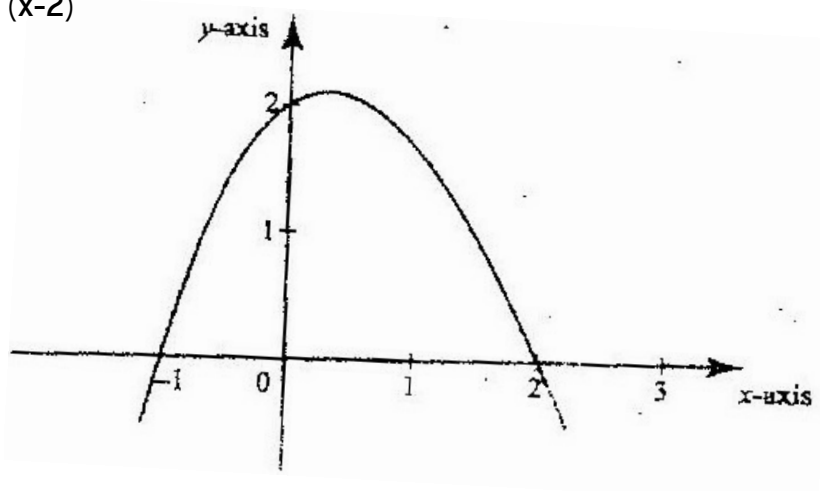

Find the value of k

10. (a) Draw the graph of $y = x^2 - 2x + 1$ for values $-2 \leq x \leq 4$
- (b) Use the graph to solve the equations $x^2 - 4 = 0$ and line $y = 2x + 5$

11. (a) Draw the graph of $y = x^3 + x^2 - 2x$ for $-3 \leq x \leq 3$ take scale of 2cm to represent 5 units as the horizontal axis
- (b) Use the graph to solve $x^3 + x^2 - 6x - 4 = 0$ by drawing a suitable linear graph on the same axes.
12. Solve graphically the simultaneous equations $3x - 2y = 5$ and $5x + y = 17$

TOPIC 2

APPROXIMATION AND ERRORS

PAST KCSE QUESTIONS ON THE TOPIC

1. (a) Work out the exact value of $R = \frac{1}{0.003146 - 0.003130}$
- (b) An approximate value of R may be obtained by first correcting each of the decimal in the denominator to 5 decimal places
- (i) The approximate value
- (ii) The error introduced by the approximation
2. The radius of circle is given as 2.8 cm to 2 significant figures
- (a) If C is the circumference of the circle, determine the limits between which $\frac{C}{r}$ lies
- (b) By taking π to be 3.142, find, to 4 significant figures the line between which the circumference lies.
3. The length and breath of a rectangular floor were measured and found to be 4.1 m and 2.2 m respectively. If possible error of 0.01 m was made in each of the measurements, find the:

(a) Maximum and minimum possible area of the floor

(b) Maximum possible wastage in carpet ordered to cover the whole floor

4. In this question Mathematical Tables should not be used

The base and perpendicular height of a triangle measured to the nearest centimeter

are 6 cm and 4 cm respectively.

Find

(a) The absolute error in calculating the area of the triangle

(b) The percentage error in the area, giving the answer to 1 decimal place

5. By correcting each number to one significant figure, approximate the value of 788×0.006 . Hence calculate the percentage error arising from this approximation.

6. A rectangular block has a square base whose side is exactly 8 cm. Its height measured to the nearest millimeter is 3.1 cm

Find in cubic centimeters, the greatest possible error in calculating its volume.

7. Find the limits within the area of a parallelogram whose base is 8cm and height is 5 cm lies. Hence find the relative error in the area

8. Find the minimum possible perimeter of a regular pentagon whose side is 15.0cm.

9. Given the number 0.237

(i) Round off to two significant figures and find the round off error

(ii) Truncate to two significant figures and find the truncation error

10. The measurements $a = 6.3$, $b = 15.8$, $c = 14.2$ and $d = 0.00173$ have maximum possible errors of 1%, 2%, 3% and 4% respectively. Find the maximum possible

percentage error in $\frac{ad}{bc}$ correct to 1sf.

TOPIC 3

TRIGONOMETRY 1

PAST KCSE QUESTIONS ON THE TOPIC 1

1. Solve the equation

$$\sin \frac{5}{2} = -\frac{1}{2} \text{ for } 0^\circ \leq \theta \leq 180^\circ$$

2. Given that $\sin \theta = \frac{2}{3}$ and θ is an acute angle find:

(a) $\tan \theta$ giving your answer in surd form

(b) $\sec^2 \theta$

3. Solve the equation $2 \sin^2(x-30^\circ) = \cos 60^\circ$ for $-180^\circ \leq x \leq 180^\circ$

4. Given that $\sin(x+30^\circ) = \cos 2x^\circ$ for $0^\circ, 0^\circ \leq x \leq 90^\circ$ find the value of x . Hence find the value of $\cos^2 3x^\circ$.

5. Given that $\sin a = \frac{1}{\sqrt{5}}$ where a is an acute angle find, without using

$\sqrt{5}$

Mathematical tables

(a) $\cos a$ in the form of $a\sqrt{b}$, where a and b are rational numbers

(b) $\tan(90^\circ - a)$.

6. Give that x° is an angle in the first quadrant such that $8 \sin^2 x + 2 \cos x - 5 = 0$

Find:

a) $\cos x$

b) $\tan x$

7. Given that $\cos 2x^\circ = 0.8070$, find x when $0^\circ \leq x \leq 360^\circ$

8. The figure below shows a quadrilateral ABCD in which $AB = 8 \text{ cm}$, $DC = 12 \text{ cm}$, \angle

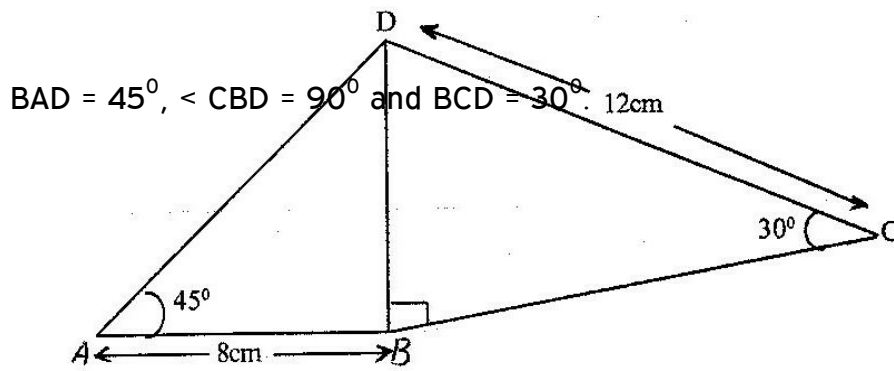

Find:

- (a) The length of BD
- (b) The size of the angle ADB

9. The diagram below represents a school gate with double shutters. The shutters are such opened through an angle of 63° .

The edges of the gate, PQ and RS are each 1.8 m

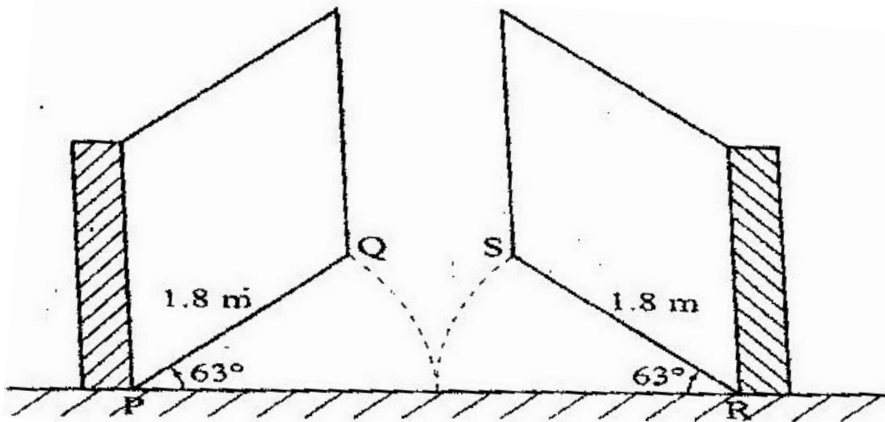

Calculate the shortest distance QS, correct to 4 significant figures

10. The figure below represents a quadrilateral piece of land ABCD divided into three triangular plots. The lengths BE and CD are 100m and 80m respectively. Angle

$\angle ABE = 30^\circ$, $\angle ACE = 45^\circ$ and $\angle ACD = 100^\circ$

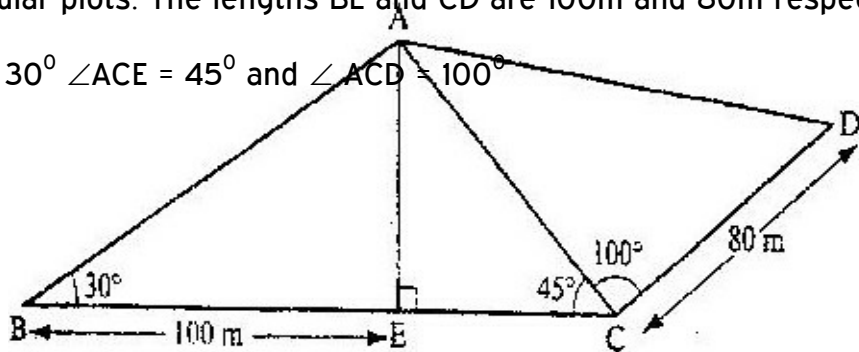

- (a) Find to four significant figures:

- (i) The length of AE
- (ii) The length of AD
- (iii) The perimeter of the piece of land

- (b) The plots are to be fenced with five strands of barbed wire leaving an entrance of 2.8 m wide to each plot. The type of barbed wire to be used is sold in rolls of lengths 480m. Calculate the number of rolls of barbed wire that must be bought to complete the fencing of the plots.

11. Given that x is an acute angle and $\cos x = \frac{2\sqrt{5}}{5}$, find without using mathematical

5

tables or a calculator, $\tan (90 - x)^\circ$.

12. In the figure below $\angle A = 62^\circ$, $\angle B = 41^\circ$, $BC = 8.4$ cm and CN is the bisector of $\angle ACB$.

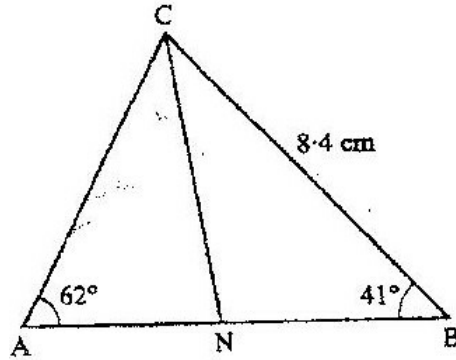

Calculate the length of CN to 1 decimal place.

13. In the diagram below PA represents an electricity post of height 9.6 m. BB and RC represents two storey buildings of heights 15.4 m and 33.4 m respectively. The angle of depression of A from B is 5.5° While the angle of elevation of C from B is 30.5° and $BC = 35$ m.

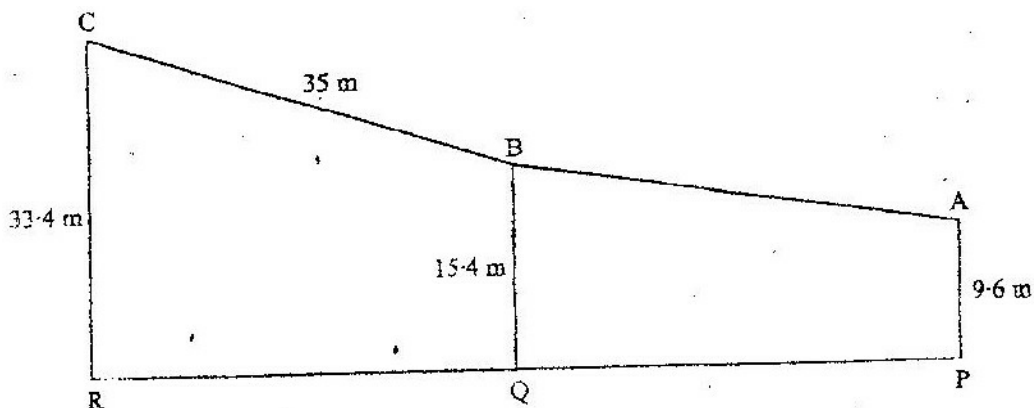

- (a) Calculate, to the nearest metre, the distance AB
- (b) By scale drawing find,
 - (i) The distance AC in metres
 - (ii) $\angle BCA$ and hence determine the angle of depression of A from C

TOPIC 4

SURDS AND FURTHER LOGARITHM

PAST KCSE QUESTIONS ON THE TOPIC

1. Without using logarithm tables, find the value of x in the equation

$$\text{Log } x^3 + \log 5x = 5 \log 2 - \log 2$$

5

2. Simplify $(1 + \sqrt{3})(1 - \sqrt{3})$

Hence evaluate $\frac{1}{1 + \sqrt{3}}$ to 3 s.f. given that $\sqrt{3} = 1.7321$

$$1 + \sqrt{3}$$

3. If $\sqrt{14} - \sqrt{14} = a\sqrt{7} + b\sqrt{2}$

$$\sqrt{7} - \sqrt{2} = \sqrt{7} + \sqrt{2}$$

Find the values of a and b where a and b are rational numbers.

4. Find the value of x in the following equation $49^{(x+1)} + 7^{(2x)} = 350$

5. Find x if $3 \log 5 + \log x^2 = \log 1/125$

6. Simplify as far as possible leaving your answer in form of a surd

$$\frac{1}{\sqrt{14} - 2\sqrt{3}} - \frac{1}{\sqrt{14} + 2\sqrt{3}}$$

7. Given that $\tan 75^\circ = 2 + \sqrt{3}$, find without using tables $\tan 15^\circ$ in the form $p+q\sqrt{m}$, where p, q and m are integers.

8. Without using mathematical tables, simplify

$$\sqrt{\frac{63}{72}} + \sqrt{\frac{32}{28}}$$

9. Simplify $\frac{3}{\sqrt{5} - 2} + \frac{1}{\sqrt{5}}$ leaving the answer in the form $a + b\sqrt{c}$, where a, b and c

$$\sqrt{5} - 2 + \sqrt{5}$$

are rational numbers

10. Given that $P = 3^y$ express the questions $3^{2y-1} + 2 \times 3^{(y-1)} = 1$ in terms of P
Hence or otherwise find the value of y in the equation: $3^{(2y-1)} + 2 \times 3^{(y-1)} = 1$
11. Solve for $(\log^3 x)^2 - \frac{1}{2} \log_3 x = \frac{3}{2}$
12. Find the values of x which satisfy the equation $5^{2x} - 6(5^x) + 5 = 0$
13. Solve the equation
 $\log(x + 24) - 2 \log 3 = \log(9 - 2x)$

TOPIC 5

COMMERCIAL ARITHMETIC

PAST KCSE QUESTIONS ON THE TOPIC

1. A business woman opened an account by depositing Kshs. 12,000 in a bank on 1st July 1995. Each subsequent year, she deposited the same amount on 1st July. The bank offered her 9% per annum compound interest. Calculate the total amount in her account on
- (a) 30th June 1996
- (b) 30th June 1997
2. A construction company requires to transport 144 tonnes of stones to sites A and B. The company pays Kshs 24,000 to transport 48 tonnes of stone for every 28

km. Kimani transported 96 tonnes to a site A, 49 km away.

- (a) Find how much he paid
- (b) Kimani spends Kshs 3,000 to transport every 8 tonnes of stones to site.
Calculate his total profit.
- (c) Achieng transported the remaining stones to sites B, 84 km away. If she made 44% profit, find her transport cost.

3. The table shows income tax rates

Monthly taxable pay	Rate of tax Kshs in 1 K£
1 – 435	2
436 – 870	3
871-1305	4
1306 – 1740	5
Excess Over 1740	6

A company employee earn a monthly basic salary of Kshs 30,000 and is also given taxable allowances amounting to Kshs 10, 480.

- (a) Calculate the total income tax
 - (b) The employee is entitled to a personal tax relief of Kshs 800 per month.
Determine the net tax.
 - (c) If the employee received a 50% increase in his total income, calculate the corresponding percentage increase on the income tax.
4. A house is to be sold either on cash basis or through a loan. The cash price is Kshs.750, 000. The loan conditions area as follows: there is to be down payment

of 10% of the cash price and the rest of the money is to be paid through a loan at 10% per annum compound interest.

A customer decided to buy the house through a loan.

- a)
 - (i) Calculate the amount of money loaned to the customer.
 - (ii) The customer paid the loan in 3 year's. Calculate the total amount paid for the house.
 - b) Find how long the customer would have taken to fully pay for the house if she paid a total of Kshs 891,750.
5. A businessman obtained a loan of Kshs. 450,000 from a bank to buy a matatu valued at the same amount. The bank charges interest at 24% per annum compound quarterly
- a) Calculate the total amount of money the businessman paid to clear the loan in $1\frac{1}{2}$ years.
 - b) The average income realized from the matatu per day was Kshs. 1500. The matatu worked for 3 years at an average of 280 days year. Calculate the total income from the matatu.
 - c) During the three years, the value of the matatu depreciated at the rate of 16% per annum. If the businessman sold the matatu at its new value, calculate the total profit he realized by the end of three years.
6. A bank either pays simple interest as 5% p.a or compound interest 5% p.a on deposits. Nekesa deposited Kshs P in the bank for two years on simple interest terms. If she had deposited the same amount for two years on compound interest terms, she would have earned Kshs 210 more.
- Calculate without using Mathematics Tables, the values of P

7. (a) A certain sum of money is deposited in a bank that pays simple interest at

a certain rate. After 5 years the total amount of money in an account is Kshs 358 400. The interest earned each year is 12 800

Calculate

- (i) The amount of money which was deposited (2mks)
 - (ii) The annual rate of interest that the bank paid (2mks)
- (b) A computer whose marked price is Kshs 40,000 is sold at Kshs 56,000 on hire purchase terms.
- (i) Kioko bought the computer on hire purchase term. He paid a deposit of 25% of the hire purchase price and cleared the balance by equal monthly installments of Kshs 2625. Calculate the number of installments (3mks)
 - (ii) Had Kioko bought the computer on cash terms he would have been allowed a discount of $12\frac{1}{2}\%$ on marked price. Calculate the difference between the cash price and the hire purchase price and express as a percentage of the cash price
 - (iii) Calculate the difference between the cash price and hire purchase price and express it as a percentage of the cash price.

8. The table below is a part of tax table for monthly income for the year 2004

Monthly taxable income In (Kshs)	Tax rate percentage (%) in each shillings
Under Kshs 9681	10%
From Kshs 9681 but under	15%

18801	
From Kshs 18801 but 27921	20%

In the tax year 2004, the tax of Kerubo's monthly income was Kshs 1916.

Calculate Kerubo's monthly income

9. The cash price of a T.V set is Kshs 13, 800. A customer opts to buy the set on hire purchase terms by paying a deposit of Kshs 2280.

If simple interest of 20 p. a is charged on the balance and the customer is required to repay by 24 equal monthly installments. Calculate the amount of each installment.

10. A plot of land valued at Kshs. 50,000 at the start of 1994.

Thereafter, every year, it appreciated by 10% of its previous years value find:

- (a) The value of the land at the start of 1995
- (b) The value of the land at the end of 1997

11. The table below shows Kenya tax rates in a certain year.

Income K £ per annum	Tax rates Kshs per K £
1- 4512	2
4513 - 9024	3
9025 - 13536	4
13537 - 18048	5
18049 - 22560	6
Over 22560	6.5

In that year Muhando earned a salary of Kshs. 16510 per month. He was entitled to a monthly tax relief of Kshs. 960

Calculate

- (a) Muhando's annual salary in K £
 - (b) (i) The monthly tax paid by Muhando in Kshs
14. A tailor intends to buy a sewing machine which costs Kshs 48,000. He borrows the money from a bank. The loan has to be repaid at the end of the second year. The bank charges an interest at the rate of 24% per annum compounded half yearly. Calculate the total amount payable to the bank.
15. The average rate of depreciation in value of a water pump is 9% per annum. After three complete years its value was Kshs 150,700. Find its value at the start of the three year period.
16. A water pump costs Kshs 21600 when new, at the end of the first year its value depreciates by 25%. The depreciation at the end of the second year is 20% and thereafter the rate of depreciation is 15% yearly. Calculate the exact value of the water pump at the end of the fourth year.

TOPIC 6

CIRCLES, CHORDS AND TANGENTS

PAST KCSE QUESTIONS ON THE TOPIC

1. The figure below represents a circle a diameter 28 cm with a sector subtending an angle of 75° at the centre

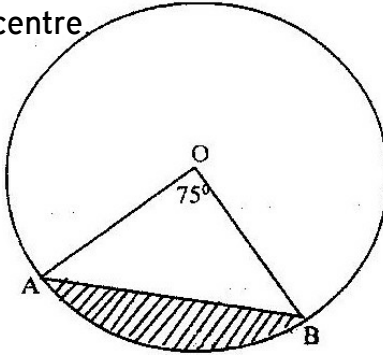

Find the area of the shaded segment to 4 significant figures

(a) \angle PST

2. The figure below represents a rectangle PQRS inscribed in a circle centre O and radius 17 cm. PQ = 16 cm.

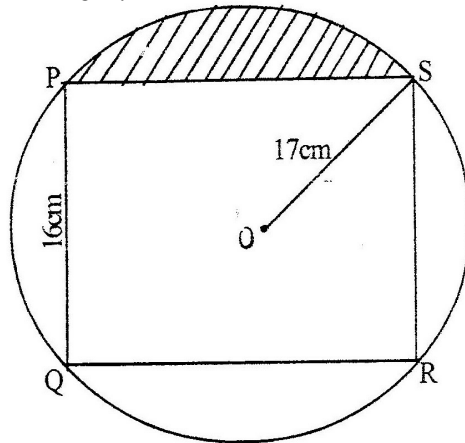

Calculate

- The length PS of the rectangle
 - The angle POS
 - The area of the shaded region
3. In the figure below, BT is a tangent to the circle at B. AXCT and BXD are straight lines. AX = 6 cm, CT = 8 cm, BX = 4.8 cm and XD = 5 cm.

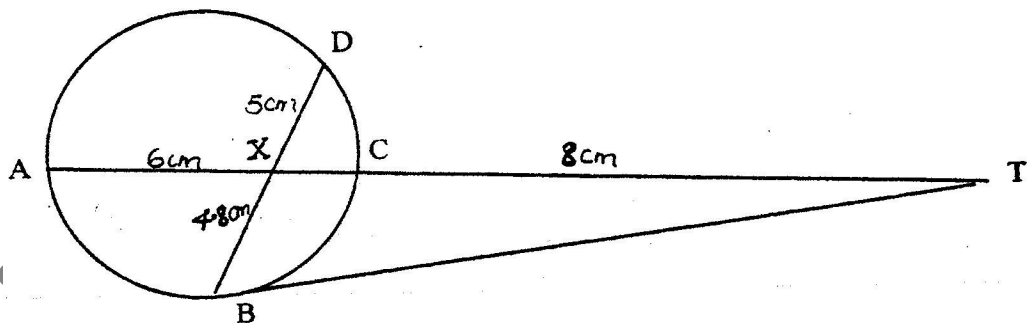

Find the length of

(a) XC

(b) BT

4. The figure below shows two circles each of radius 7 cm, with centers at X and Y. The circles touch each other at point Q.

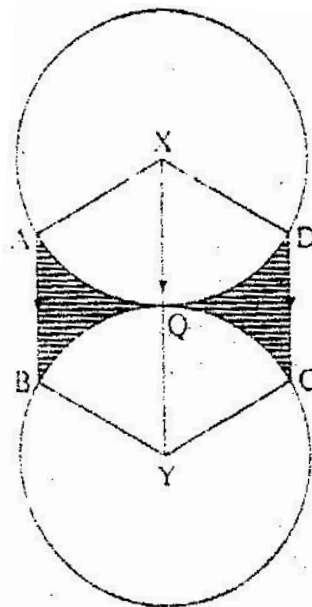

Given that $\angle AXD = \angle BYC = 120^\circ$ and lines AB, XQY and DC are parallel, calculate the area of:

- Minor sector XAQD (Take $\pi^{22/7}$)
 - The trapezium XABY
 - The shaded regions.
5. The figure below shows a circle, centre, O of radius 7 cm. TP and TQ are tangents to the circle at points P and Q respectively. OT = 25 cm.

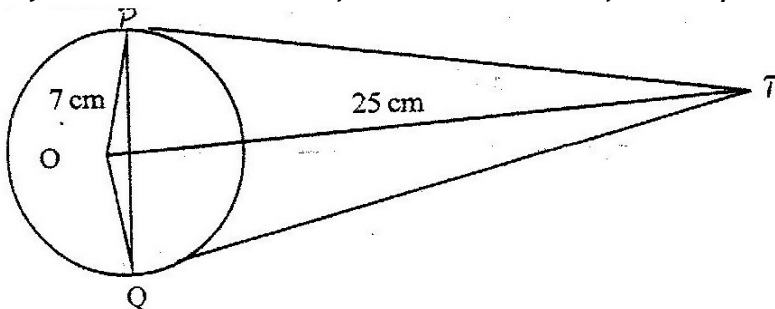

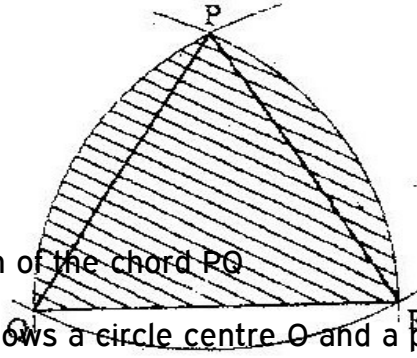

Calculate the length of the chord PQ

6. The figure below shows a circle centre O and a point Q which is outside the circle

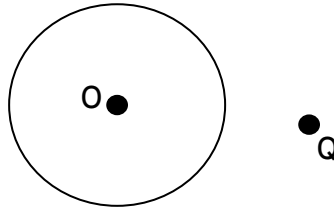

Using a ruler and a pair of compasses, only locate a point on the circle such that angle OPQ = 90°

7. In the figure below, PQR is an equilateral triangle of side 6 cm. Arcs QR, PR and PQ arcs of circles with centers at P, Q and R respectively.

Calculate the area of the shaded region to 4 significant figures

8. In the figure below AB is a diameter of the circle. Chord PQ intersects AB at N. A tangent to the circle at B meets PQ produced at R.

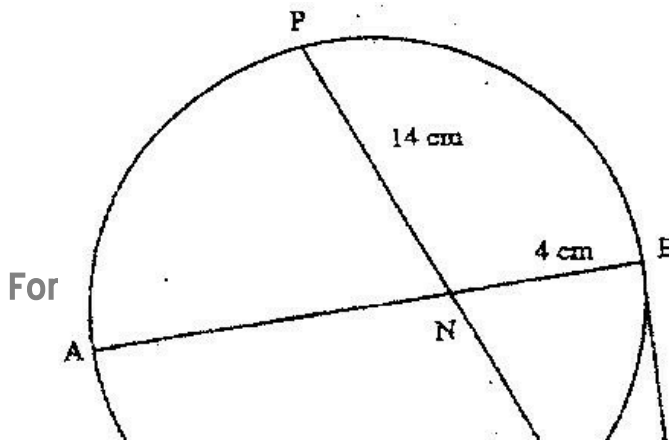

For

Given that $PN = 14$ cm, $NB = 4$ cm and $BR = 7.5$ cm, calculate the length of:

- (a) NR
- (b) AN

TOPIC 7

MATRICES

PAST KCSE QUESTIONS ON THE TOPIC

1. A and B are two matrices. If $A = \begin{pmatrix} 1 & 2 \\ 4 & 3 \end{pmatrix}$ find B given that $A^2 = A + B$
2. Given that $A = \begin{pmatrix} 1 & 3 \\ 5 & 3 \end{pmatrix}$, $B = \begin{pmatrix} 3 & 1 \\ 5 & -1 \end{pmatrix}$, $C = \begin{pmatrix} p & 0 \\ 0 & q \end{pmatrix}$ and $AB = BC$, determine the value of P
3. A matrix A is given by $A = \begin{pmatrix} x & 0 \\ 5 & y \end{pmatrix}$

a) Determine A^2

$$\left(\begin{array}{cc} & \\ & \end{array} \right)$$

b) If $A^2 = \begin{pmatrix} 1 & 0 \\ 0 & 1 \end{pmatrix}$, determine the possible pairs of values of x and y

4. (a) Find the inverse of the matrix $\begin{pmatrix} 9 & 8 \\ 7 & 6 \end{pmatrix}$
- (b) In a certain week a businessman bought 36 bicycles and 32 radios for total of Kshs 227 280. In the following week, he bought 28 bicycles and 24 radios for a total of Kshs 174 960. Using matrix method, find the price of each bicycle and each radio that he bought
- (c) In the third week, the price of each bicycle was reduced by 10% while the price of each radio was raised by 10%. The businessman bought as many bicycles and as many radios as he had bought in the first two weeks. Find by matrix method, the total cost of the bicycles and radios that the businessman bought in the third week.

5. Determine the inverse T^{-1} of the matrix $\begin{pmatrix} 1 & 2 \\ 1 & -1 \end{pmatrix}$

Hence find the coordinates to the point at which the two lines $x + 2y=7$ and $x-y=1$

6. Given that $A = \begin{pmatrix} 0 & -1 \\ 3 & 2 \end{pmatrix}$ and $B = \begin{pmatrix} -1 & 0 \\ 2 & -4 \end{pmatrix}$

Find the value of x if

- (i) $A - 2x = 2B$
- (ii) $3x - 2A = 3B$
- (iii) $2A - 3B = 2x$

7. Find the non-zero value of k for which $\begin{pmatrix} k+1 & 2 \\ 4k & 2k \end{pmatrix}$ is an inverse.
8. A clothes dealer sold 3 shirts and 2 trousers for Kshs. 840 and 4 shirts and 5 trousers for Kshs 1680. Form a matrix equation to represent the above information. Hence find the cost of 1 shirt and the cost of 1 trouser.

TOPIC 8

FORMULAE AND VARIATIONS

PAST KCSE QUESTIONS ON THE TOPIC

1. The volume $V\text{cm}^3$ of an object is given by

$$V = \frac{2}{3} \pi r^3 \left(\frac{1}{s} - 2 \right)$$

Express in term of π , r , s and V

2. Make V the subject of the formula

$$T = \frac{1}{2} m (u^2 - v^2)$$

3. Given that $y = \frac{b - bx^2}{cx^2 - a}$ make x the subject

4. Given that $\log y = \log (10^n)$ make n the subject

5. A quantity T is partly constant and partly varies as the square root of S .

i. Using constants a and b , write down an equation connecting T and S .

ii. If $S = 16$, when $T = 24$ and $S = 36$ when $T = 32$, find the values of the

constants a and b,

6. A quantity P is partly constant and partly varies inversely as a quantity q, given that $p = 10$ when $q = 1.5$ and $p = 20$, when $q = 1.25$, find the value of p when $q = 0.5$

7. Make y the subject of the formula $p = \frac{xy}{x-y}$

$$x-y$$

8. Make P the subject of the formula

$$P^2 = (P - q) (P-r)$$

9. The density of a solid spherical ball varies directly as its mass and inversely as the cube of its radius

When the mass of the ball is 500g and the radius is 5 cm, its density is 2 g per cm^3

Calculate the radius of a solid spherical ball of mass 540 density of 10g per cm^3

10. Make s the subject of the formula

$$\sqrt{P} = r \sqrt{1 - as^2}$$

11. The quantities t, x and y are such that t varies directly as x and inversely as the square root of y. Find the percentage in t if x decreases by 4% when y increases by 44%

12. Given that y is inversely proportional to x^n and k as the constant of proportionality;

- (a) (i) Write down a formula connecting y, x, n and k
- (ii) If $x = 2$ when $y = 12$ and $x = 4$ when $y = 3$, write down two expressions for k in terms of n.
- Hence, find the value of n and k.

- (b) Using the value of n obtained in (a) (ii) above, find y when $x = 5\frac{1}{3}$
13. The electrical resistance, R ohms of a wire of a given length is inversely proportional to the square of the diameter of the wire, d mm. If $R = 2.0$ ohms when $d = 3$ mm. Find the value R when $d = 4$ mm.
14. The volume V cm³ of a solid depends partly on r and partly on r where r cm is one of the dimensions of the solid.
When $r = 1$, the volume is 54.6 cm³ and when $r = 2$, the volume is 226.8 cm³
- (a) Find an expression for V in terms of r
- (b) Calculate the volume of the solid when $r = 4$
- (c) Find the value of r for which the two parts of the volume are equal
15. The mass of a certain metal rod varies jointly as its length and the square of its radius. A rod 40 cm long and radius 5 cm has a mass of 6 kg. Find the mass of a similar rod of length 25 cm and radius 8 cm.
16. Make x the subject of the formula
- $$P = \frac{xy}{z + x}$$
17. The charge c shillings per person for a certain service is partly fixed and partly inversely proportional to the total number N of people.
- (a) Write an expression for c in terms on N
- (b) When 100 people attended the charge is Kshs 8700 per person while for

35 people the charge is Kshs 10000 per person.

- (c) If a person had paid the full amount charge is refunded. A group of people paid but ten percent of organizer remained with Kshs 574000.

Find the number of people.

18. Two variables A and B are such that A varies partly as B and partly as the square root of B given that A=30, when B=9 and A=16 when B=14, find A when B=36.

19. Make p the subject of the formula

$$A = \frac{-EP}{\sqrt{P^2 + N}}$$

TOPIC 9

SEQUENCE AND SERIES

PAST KCSE QUESTIONS ON THE TOPIC

1. The first, the third and the seventh terms of an increasing arithmetic progression are three consecutive terms of a geometric progression. In the first term of the arithmetic progression is 10 find the common difference of the arithmetic progression.
2. Kubai saved Kshs 2,000 during the first year of employment. In each subsequent year, he saved 15% more than the preceding year until he retired.
 - (a) How much did he save in the second year?

- (b) How much did he save in the third year?
- (c) Find the common ratio between the savings in two consecutive years
- (d) How many years did he take to save the savings a sum of Kshs 58,000?
- (e) How much had he saved after 20 years of service?
3. In geometric progression, the first is a and the common ratio is r . The sum of the first two terms is 12 and the third term is 16.
- (a) Determine the ratio $\frac{ar^2}{a + ar}$
- (b) If the first term is larger than the second term, find the value of r .
4. (a) The first term of an arithmetic progression is 4 and the last term is 20. The sum of the term is 252. Calculate the number of terms and the common differences of the arithmetic progression
- (b) An Experimental culture has an initial population of 50 bacteria. The population increased by 80% every 20 minutes. Determine the time it will take to have a population of 1.2 million bacteria.
5. Each month, for 40 months, Amina deposited some money in a saving scheme. In the first month she deposited Kshs 500. Thereafter she increased her deposits by Kshs. 50 every month.
- Calculate the:
- a) Last amount deposited by Amina
- b) Total amount Amina had saved in the 40 months.
6. A carpenter wishes to make a ladder with 15 cross- pieces. The cross- pieces are to diminish uniformly in length from 67 cm at the bottom to 32 cm at the top.

Calculate the length in cm, of the seventh cross- piece from the bottom

7. The second and fifth terms of a geometric progression are 16 and 2 respectively. Determine the common ratio and the first term.
8. The eleventh term of an arithmetic progression is four times its second term. The sum of the first seven terms of the same progression is 175
- (a) Find the first term and common difference of the progression
- (b) Given that p^{th} term of the progression is greater than 124, find the least value of P
9. The n^{th} term of sequence is given by $2n + 3$ of the sequence
- (a) Write down the first four terms of the sequence
- (b) Find s_n the sum of the fifty term of the sequence
- (c) Show that the sum of the first n terms of the sequence is given by
- $$S_n = n^2 + 4n$$

Hence or otherwise find the largest integral value of n such that $S_n < 725$

TOPIC 10

VECTORS

PAST KCSE QUESTIONS ON THE TOPIC

1. The figure below is a right pyramid with a rectangular base ABCD and VO as the height. The vectors $AD = a$, $AB = b$ and $DV = v$

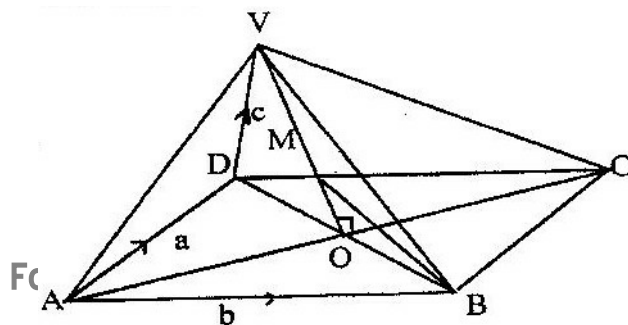

a) Express

(i) AV in terms of a and c

(ii) BV in terms of a , b and c

(b) M is point on OV such that $OM: MV=3:4$, Express BM in terms of a , b and c .

Simplify your answer as far as possible

2. In triangle OAB , $OA = a$ $OB = b$ and P lies on AB such that $AP: BP = 3:5$

(a) Find in terms of a and b the vectors

(i) AB

(ii) AP

(iii) BP

(iv) OP

(b) Point Q is on OP such $AQ = \frac{-5}{8}a + \frac{9}{40}b$

$8a - 40b$

Find the ratio $OQ: QP$

3. The figure below shows triangle OAB in which M divides OA in the ratio $2:3$ and N divides OB in the ratio $4:1$ AN and BM intersect at X

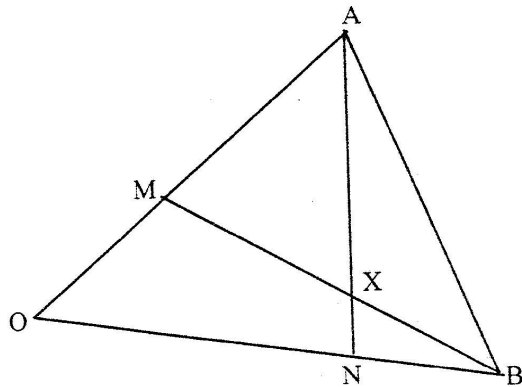

- (a) Given that $OA = a$ and $OB = b$, express in terms of a and b :
- (i) AN
 - (ii) BM
- (b) If $AX = s AN$ and $BX = tBM$, where s and t are constants, write two expressions for OX in terms of a, b, s and t

Find the value of s

Hence write OX in terms of a and b

4. The position vectors for points P and Q are $4i + 3j + 6k$ and $pj + 6k$ respectively. Express vector PQ in terms of unit vectors i, j and k . Hence find the length of PQ , leaving your answer in simplified surd form.

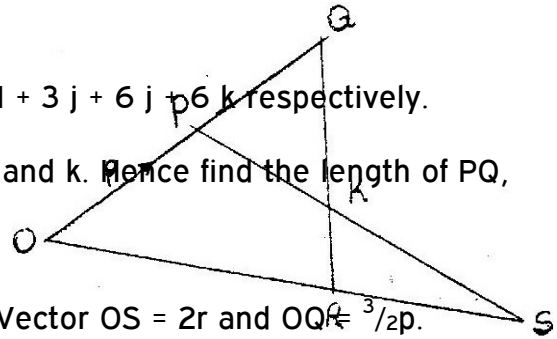

5. In the figure below, vector $OP = p$ and $OR = r$. Vector $OS = 2r$ and $OQ = \frac{3}{2}p$.
- a) Express in terms of p and r (i) QR and (ii) PS
 - b) The lines QR and PS intersect at K such that $QK = m QR$ and $PK = n PS$, where m and n are scalars. Find two distinct expressions for OK in terms of p, r, m and n . Hence find the values of m and n .
 - c) State the ratio $PK: KS$
6. Point T is the midpoint of a straight line AB . Given the position vectors of A and T are $i - j + k$ and $2i + \frac{1}{2}k$ respectively, find the position vector of B in terms of i, j and k
7. A point R divides a line PQ internally in the ratio $3:4$. Another point S , divides the line PR externally in the ratio $5:2$. Given that $PQ = 8$ cm, calculate the

length of RS, correct to 2 decimal places.

8. The points P, Q, R and S have position vectors $2p$, $3p$, r and $3r$ respectively, relative to an origin O. A point T divides PS internally in the ratio 1:6

- (a) Find, in the simplest form, the vectors OT and QT in terms p and r
- (b) (i) Show that the points Q, T, and R lie on a straight line
- (ii) Determine the ratio in which T divides QR

9. Two points P and Q have coordinates $(-2, 3)$ and $(1, 3)$ respectively. A translation map point P to P' $(10, 10)$

- (a) Find the coordinates of Q' the image of Q under the translation
- (b) The position vector of P and Q in (a) above are p and q respectively given

$$\text{that } mp - nq = \begin{pmatrix} -12 \\ 9 \end{pmatrix}$$

Find the value of m and n

10. Given that $q\mathbf{i} + \frac{1}{3}j + \frac{2}{3}k$ is a unit vector, find q

11. In the diagram below, the coordinates of points A and B are $(1, 6)$ and $(15, 6)$ respectively). Point N is on OB such that $3ON = 2OB$. Line OA is produced to L such that $OL = 3OA$

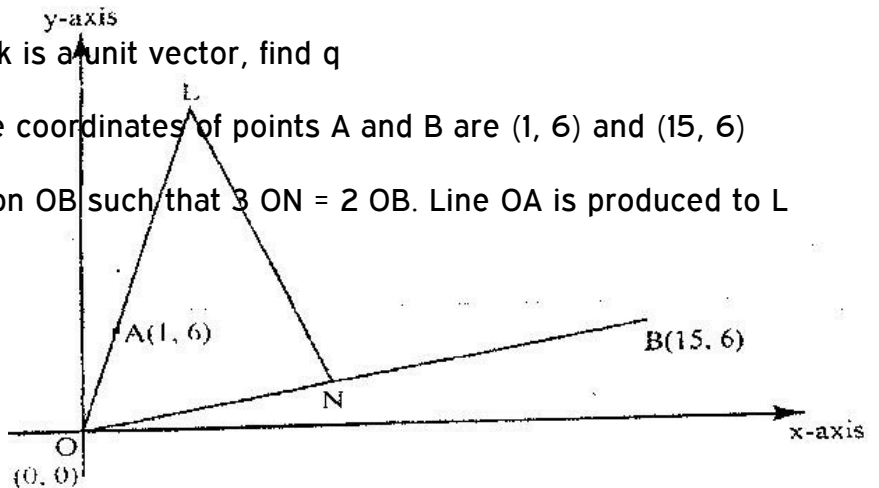

- (a) Find vector LN
- (b) Given that a point M is on LN such that $LM:MN = 3:4$, find the coordinates of M
- (c) If line OM is produced to T such that $OM:MT = 6:1$
 - (i) Find the position vector of T
 - (ii) Show that points L, T and B are collinear

12. In the figure below, $OQ = q$ and $OR = r$. Point X divides OQ in the ratio 1: 2 and Y divides OR in the ratio 3: 4 lines XR and YQ intersect at E.

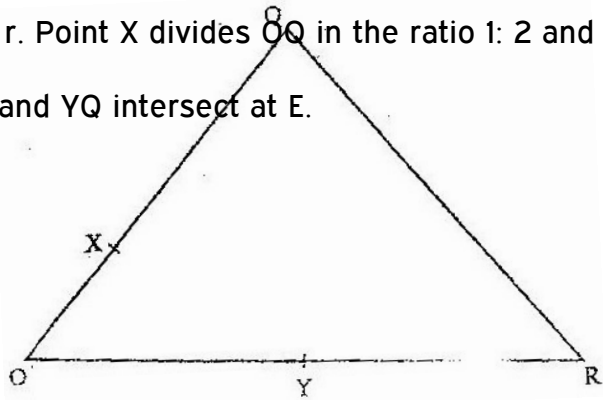

- (a) Express in terms of q and r
 - (i) XR
 - (ii) YQ
 - (b) If $XE = m XR$ and $YE = n YQ$, express OE in terms of:
 - (i) r, q and m
 - (ii) r, q and n
 - (c) Using the results in (b) above, find the values of m and n .
13. Vector q has a magnitude of 7 and is parallel to vector p . Given that $p = 3i - j + 1\frac{1}{2}k$, express vector q in terms of i, j , and k .

14. In the figure below, $OA = 3i + 3j$ ABD $OB = 8i - j$. C is a point on AB such that $AC:CB = 3:2$, and D is a point such that $OB \parallel CD$ and $2OB = CD$ (T17)

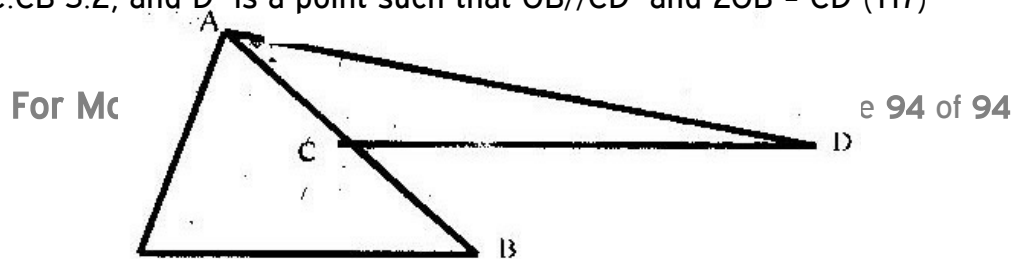

Determine the vector DA in terms of I and j

15. In the figure below, KLMN is a trapezium in which KL is parallel to NM and $KL = 3NM$

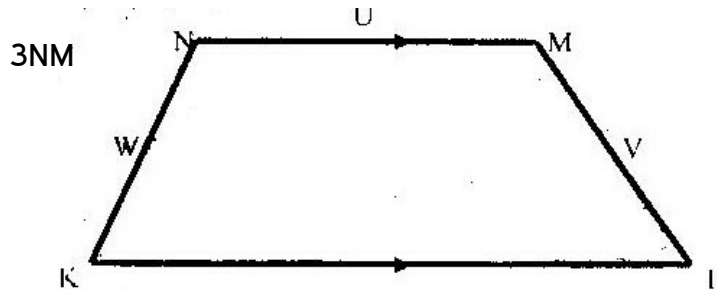

Given that $KN = w$, $NM = u$ and $ML = v$. Show that $2u = v + w$

16. The points P, Q and R lie on a straight line. The position vectors of P and R are $2i + 3j + 13k$ and $5i - 3j + 4k$ respectively; Q divides SR internally in the ratio 2: 1.

Find the

- Position vector of Q
 - Distance of Q from the origin
17. Co-ordinates of points O, P, Q and R are (0, 0), (3, 4), (11, 6) and (8, 2) respectively. A point T is such that the vector OT, QP and QR satisfy the vector equation $OT = QP + \frac{1}{2} QT$. Find the coordinates of T.
18. In the figure below $OA = a$, $OB = b$, $AB = BC$ and $OB: BD = 3:1$

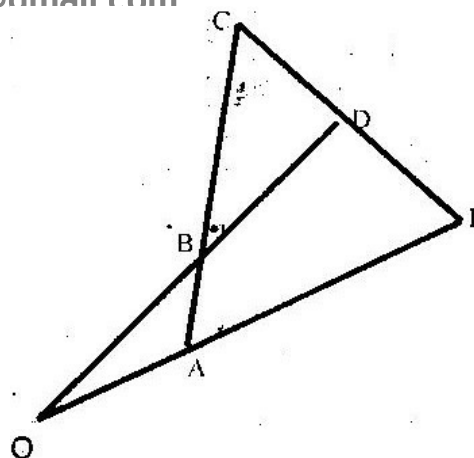

- (a) Determine
- (i) AB in terms of a and b
 - (ii) CD , in terms of a and b
- (b) If $CD:DE = 1:k$ and $OA:AE = 1:m$ determine
- (i) DE in terms of a , b and k
 - (ii) The values of k and m

19. The figure below shows a grid of equally spaced parallel lines

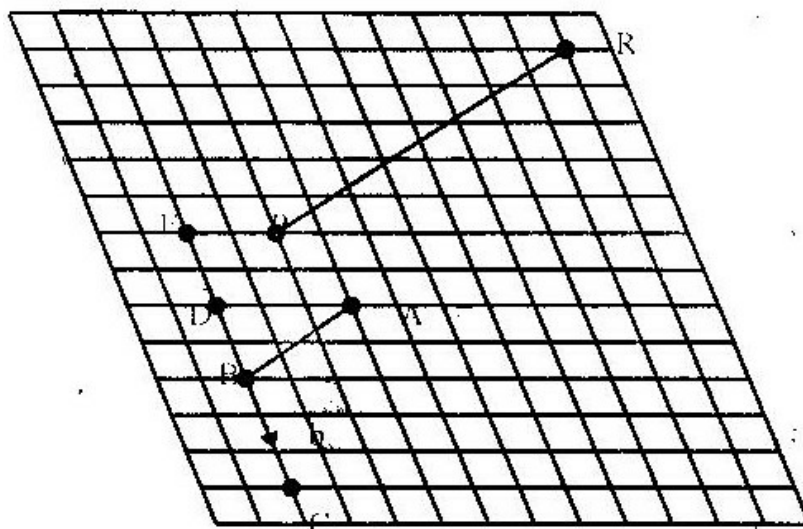

$\overrightarrow{AB} = a$ and $\overrightarrow{BC} = b$

- (a) Express
- (i) \overrightarrow{AC} in terms of a and b
 - (ii) AD in terms of a and b
- (b) Using triangle BEP , express BP in terms of a and b

(c) PR produced meets BA produced at X and $PR = \frac{1}{9}b - \frac{8}{3}a$

By writing PX as kPR and BX as hBA and using the triangle BPX determine the ratio PR: RX

20. The position vectors of points x and y are $x = 2i + j - 3k$ and $y = 3i + 2j - 2k$ respectively. Find XY

21. Given that $X = 2i + j - 2k$, $y = -3i + 4j - k$ and $z = 5i + 3j + 2k$ and that $p = 3x - y + 2z$, find the magnitude of vector p to 3 significant figures.

TOPIC 11

BINOMIAL EXPRESSION

PAST KCSE QUESTIONS ON THE TOPIC

- Write down the simplest expansion $(1 + x)^6$
 - Use the expansion up to the fourth term to find the value of $(1.03)^6$ to the nearest one thousandth.
- Use binomial expression to evaluate $(0.96)^5$ correct to 4 significant figures.
- Expand and simplify $(3x - y)^4$ hence use the first three terms of the expansion to approximate the value of $(6 - 0.2)^4$
- Abdi and Amoit were employed at the beginning of the same year. Their annual salaries in shillings progressed as follows
Abdi: 60000, 64800, 69600
Amoit: 60000, 64800, 69984
 - Calculate Abdi's annual salary increment and hence write down an expression for his annual salary in his n^{th} year of employment?

- (b) Calculate Amoit's annual percentage rate of salary increment and hence write down an expression for her annual salary in her n^{th} year employment?
- (c) Calculate the difference in the annual salary for Abdi and Amoit in their 7th year of employment.

5. Use binomial expression to evaluate

$$\left(2 + \frac{1}{\sqrt{2}}\right)^5 + \left(2 - \frac{1}{\sqrt{2}}\right)^5$$

6. (a) Expand the expression $\left(1 + \frac{x}{2}\right)^5$ in ascending powers of x , leaving the coefficients as fractions in their simplest form.

- (b) Use the first three terms of the expression in (a) above to estimate the value of $\left(1 + \frac{1}{20}\right)^5$

7. (a) Expand $(a - b)^6$
- (b) Use the first three terms of the expansion in (a) above to find the approximate value of $(1.98)^6$

8. Expand $(2 + x)^5$ in ascending powers of x up to the term in x^3 hence approximate the value of $(2.03)^5$ to 4 s.f

9. (a) Expand $(1 + x)^5$
- Hence use the expansion to estimate $(1.04)^5$ correct to 4 decimal places
- (b) Use the expansion up to the fourth term to find the value of $(1.03)^6$ to the nearest one thousandth.

10. Expand and Simplify $(1-3x)^5$ up to the term in x^3
Hence use your expansion to estimate $(0.97)^5$ correct to decimal places.
11. Expand $(1 + a)^5$
Use your expansion to evaluate $(0.8)^5$ correct to four places of decimal
12. (a) Expand $(1 + x)^5$
(b) Use the first three terms of the expansion in (a) above to find the approximate value of $(0.98)^5$

TOPIC 12

PROBABILITY

PAST KCSE QUESTIONS ON THE TOPIC

1. The probabilities that a husband and wife will be alive 25 years from now are 0.7 and 0.9 respectively.
Find the probability that in 25 years time,
(a) Both will be alive
(b) Neither will be alive
(c) One will be alive
(d) At least one will be alive
2. A bag contains blue, green and red pens of the same type in the ratio 8:2:5

respectively. A pen is picked at random without replacement and its colour noted

- (a) Determine the probability that the first pen picked is
 - (i) Blue
 - (ii) Either green or red
 - (b) Using a tree diagram, determine the probability that
 - (i) The first two pens picked are both green
 - (ii) Only one of the first two pens picked is red.
3. A science club is made up of boys and girls. The club has 3 officials. Using a tree diagram or otherwise find the probability that:
- (a) The club officials are all boys
 - (b) Two of the officials are girls
4. Two baskets A and B each contain a mixture of oranges and limes, all of the same size. Basket A contains 26 oranges and 13 limes. Basket B contains 18 oranges and 15 limes. A child selected a basket at random and picked a fruit at a random from it.
- (a) Illustrate this information by a probabilities tree diagram
 - (b) Find the probability that the fruit picked was an orange.
5. In form 1 class there are 22 girls and boys. The probability of a girl completing the secondary education course is $\frac{3}{4}$ whereas that of a boy is $\frac{2}{3}$
- (a) A student is picked at random from class. Find the possibility that,
 - (i) The student picked is a boy and will complete the course
 - (ii) The student picked will complete the course
 - (b) Two students are picked at random. Find the possibility that they are a boy and a girl and that both will not complete the course.

6. Three representatives are to be selected randomly from a group of 7 girls and 8 boys. Calculate the probability of selecting two girls and one boy.
7. A poultry farmer vaccinated 540 of his 720 chickens against a disease. Two months later, 5% of the vaccinated and 80% of the unvaccinated chicken, contracted the disease. Calculate the probability that a chicken chosen random contacted the disease.
8. The probability of three darts players Akinyi, Kamau, and Juma hitting the bulls eye are 0.2, 0.3 and 1.5 respectively.
- (a) Draw a probability tree diagram to show the possible outcomes
 - (b) Find the probability that:
 - (i) All hit the bull's eye
 - (ii) Only one of them hit the bull's eye
 - (iii) At most one missed the bull's eye
9. (a) An unbiased coin with two faces, head (H) and tail (T), is tossed three times, list all the possible outcomes.
- Hence determine the probability of getting:
- (i) At least two heads
 - (ii) Only one tail
- (b) During a certain motor rally it is predicted that the weather will be either dry (D) or wet (W). The probability that the weather will be dry is estimated to be $\frac{7}{10}$. The probability for a driver to complete (C) the rally during the dry weather is estimated to be $\frac{5}{6}$. The probability for a driver to complete the rally during wet weather is estimated to be $\frac{1}{10}$. Complete the probability tree diagram given below.

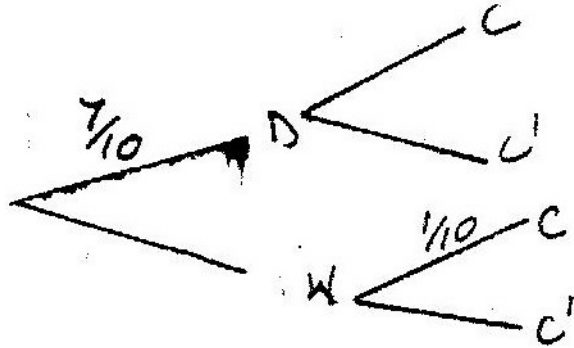

What is the probability that:

- (i) The driver completes the rally?
 - (ii) The weather was wet and the driver did not complete the rally?
10. There are three cars A, B and C in a race. A is twice as likely to win as B while B is twice as likely to win as c. Find the probability that.
- a) A wins the race
 - b) Either B or C wins the race.
11. In the year 2003, the population of a certain district was 1.8 million. Thirty per cent of the population was in the age group 15 – 40 years. In the same year, 120,000 people in the district visited the Voluntary Counseling and Testing (VCT) centre for an HIV test.
- If a person was selected at random from the district in this year. Find the probability that the person visited a VCT centre and was in the age group 15 – 40 years.
12. (a) Two integers x and y are selected at random from the integers 1 to 8. If

the

same integer may be selected twice, find the probability that

(i) $|x - y| = 2$

(ii) $|x - y|$ is 5 or more

(iii) $x > y$

(b) A die is biased so that when tossed, the probability of a number r showing up, is given by $p \propto Kr$ where K is a constant and $r = 1, 2, 3, 4, 5$ and 6 (the number on the faces of the die

(i) Find the value of K

(ii) If the die is tossed twice, calculate the probability that the total score is 11

13. Two bags A and B contain identical balls except for the colours. Bag A contains 4 red balls and 2 yellow balls. Bag B contains 2 red balls and 3 yellow balls.

(a) If a ball is drawn at random from each bag, find the probability that both balls are of the same colour.

(b) If two balls are drawn at random from each bag, one at a time without replacement, find the probability that:

(i) The two balls drawn from bag A or bag B are red

(ii) All the four balls drawn are red

14. During inter – school competitions, football and volleyball teams from Mokagu high school took part. The probability that their football and volleyball teams would win were $\frac{3}{8}$ and $\frac{4}{7}$ respectively.

Find the probability that

- (a) Both their football and volleyball teams
 - (b) At least one of their teams won
15. A science club is made up of 5 boys and 7 girls. The club has 3 officials. Using a tree diagram or otherwise find the probability that:
- (a) The club officials are all boys
 - (b) Two of the officials are girls
16. Chicks on Onyango's farm were noted to have either brown feathers brown or black tail feathers. Of those with black feathers $\frac{2}{3}$ were female while $\frac{2}{5}$ of those with brown feathers were male. Otieno bought two chicks from Onyango. One had black tail feathers while the other had brown find the probability that Otieno's chicks were not of the same gender
17. Three representatives are to be selected randomly from a group of 7 girls and 8 boys. Calculate the probability of selecting two girls and one boy
18. The probability that a man wins a game is $\frac{3}{4}$. He plays the game until he wins. Determine the probability that he wins in the fifth round.
19. The probability that Kamau will be selected for his school's basketball team is $\frac{1}{4}$. If he is selected for the basketball team. Then the probability that he will be selected for football is $\frac{1}{3}$ if he is not selected for basketball then the probability that he is selected for football is $\frac{4}{5}$. What is the probability that Kamau is selected for at least one of the two games?

20. Two baskets A and B each contains a mixture of oranges and lemons. Basket A contains 26 oranges and 13 lemons. Basket B contains 18 oranges and 15 lemons. A child selected a basket at random and picked at random a fruit from it. Determine the probability that the fruit picked was an orange.

TOPIC 13

COMPOUND PROPORTION AND MIXTURES

PAST KCSE QUESTIONS ON THE TOPIC

1. Akinyi bought maize and beans from a wholesaler. She then mixed the maize and beans in the ratio 4:3 she bought the maize at Kshs. 12 per kg and the beans at 4 per kg. If she was to make a profit of 30% what should be the selling price of 1 kg of the mixture?
2. A rectangular tank of base 2.4 m by 2.8 m and a height of 3 m contains 3,600 liters of water initially. Water flows into the tank at the rate of 0.5 litres per second
Calculate the time in hours and minutes, required to fill the tank
3. A company is to construct a parking bay whose area is 135m^2 . It is to be covered with concrete slab of uniform thickness of 0.15. To make the slab cement, ballast and sand are to be mixed so that their masses are in the ratio 1: 4: 4. The mass of m^3 of dry slab is 2, 500kg.
Calculate
 - (a) (i) The volume of the slab
 - (ii) The mass of the dry slab

- (iii) The mass of cement to be used
- (b) If one bag of the cement is 50 kg, find the number of bags to be purchased
- (c) If a lorry carries 7 tonnes of sand, calculate the number of lorries of sand to be purchased.
4. The mass of a mixture A of beans and maize is 72 kg. The ratio of beans to maize is 3:5 respectively
- (a) Find the mass of maize in the mixture
- (b) A second mixture of B of beans and maize of mass 98 kg is mixed with A. The final ratio of beans to maize is 8:9 respectively. Find the ratio of beans to maize in B
5. A retailer bought 49 kg of grade 1 rice at Kshs. 65 per kilogram and 60 kg of grade II rice at Kshs 27.50 per kilogram. He mixed the two types of rice.
- (a) Find the buying price of one kilogram of the mixture
- (b) He packed the mixture into 2 kg packets
- (i) If he intends to make a 20% profit find the selling price per packet
- (ii) He sold 8 packets and then reduced the price by 10% in order to attract customers. Find the new selling price per packet.
- (iii) After selling $\frac{1}{3}$ of the remainder at reduced price, he raised the price so as to realize the original goal of 20% profit overall. Find the selling price per packet of the remaining rice.
6. A trader sells a bag of beans for Kshs 1,200. He mixed beans and maize in the ratio 3: 2. Find how much the trader should he sell a bag of the mixture to realize the same profit?

7. Pipe A can fill an empty water tank in 3 hours while, pipe B can fill the same tank in 6 hours, when the tank is full it can be emptied by pipe C in 8 hours. Pipes A and B are opened at the same time when the tank is empty.

If one hour later, pipe C is also opened, find the total time taken to fill the tank

8. A solution whose volume is 80 litres is made 40% of water and 60% of alcohol. When litres of water are added, the percentage of alcohol drops to 40%

(a) Find the value of x

(b) Thirty litres of water is added to the new solution. Calculate the percentage

(c) If 5 litres of the solution in (b) is added to 2 litres of the original solution, calculate in the simplest form, the ratio of water to that of alcohol in the resulting solution

9. A tank has two inlet taps P and Q and an outlet tap R. when empty, the tank can be filled by tap P alone in $4\frac{1}{2}$ hours or by tap Q alone in 3 hours. When full, the tank can be emptied in 2 hours by tap R.

(a) The tank is initially empty. Find how long it would take to fill up the tank

(i) If tap R is closed and taps P and Q are opened at the same time

(2mks)

(ii) If all the three taps are opened at the same time

(b) The tank is initially empty and the three taps are opened as follows

P at 8.00 a.m

Q at 8.45 a.m

R at 9.00 a.m

(i) Find the fraction of the tank that would be filled by 9.00 a.m

(ii) Find the time the tank would be fully filled up

10. Kipketer can cultivate a piece of land in 7 hrs while Wanjiru can do the same work in 5 hours. Find the time they would take to cultivate the piece of land when working together.

11. Mogaka and Ondiso working together can do a piece of work in 6 days. Mogaka, working alone, takes 5 days longer than Onduso. How many days does it take Onduso to do the work alone.

12. Wainaina has two dairy farms A and B. Farm A produces milk with $3\frac{1}{4}$ percent fat and farm B produces milk with $4\frac{1}{4}$ percent fat.

(a) (i) The total mass of milk fat in 50 kg of milk from farm A and 30kg of milk from farm B.

(ii) The percentage of fat in a mixture of 50 kg of milk A and 30 kg of milk from B

(b) Determine the range of values of mass of milk from farm B that must be used in a 50 kg mixture so that the mixture may have at least 4 percent fat.

13. A construction firm has two tractors T_1 and T_2 . Both tractors working together can complete the work in 6 days while T_1 alone can complete the work in 15 days. After the two tractors had worked together for four days, tractor T_1 broke down. Find the time taken by tractor T_2 complete the remaining work.

14. The points P, Q, R and S have position vectors $2p$, $3p$, r and $3r$ respectively, relative to an origin O. A point T divides PS internally in the ratio 1: 6
- (a) Find in the simplest form, the vectors OT and QT in terms of P and r
- (b) (i) Show that the points Q, T and R lie on a straight line.
 (ii) Determine the ratio in which T divides QR.

TOPIC 14

GRAPHICAL METHODS

PAST KCSE QUESTIONS ON THE TOPIC

1. The table shows the height metres of an object thrown vertically upwards varies with the time t seconds

The relationship between s and t is represented by the equations $s = at^2 + bt + 10$ where b are constants.

t	0	1	2	3	4	5	6	7	8	9	10
s		45.1						49.9			- 80

- (c) (i) Using the information in the table, determine the values of a and b
 (ii) Complete the table
- (b) (i) Draw a graph to represent the relationship between s and t
 (ii) Using the graph determine the velocity of the object when $t = 5$

seconds

2. Data collected from an experiment involving two variables X and Y was recorded as shown in the table below

x	1.1	1.2	1.3	1.4	1.5	1.6
y	-0.3	0.5	1.4	2.5	3.8	5.2

The variables are known to satisfy a relation of the form $y = ax^3 + b$ where a and b are constants

- (a) For each value of x in the table above, write down the value of x^3
- (b) (i) By drawing a suitable straight line graph, estimate the values of a and b
(ii) Write down the relationship connecting y and x
3. Two quantities P and r are connected by the equation $p = kr^n$. The table of values of P and r is given below.

P	1.2	1.5	2.0	2.5	3.5	4.5
r	1.58	2.25	3.39	4.74	7.86	11.5

- a) State a linear equation connecting P and r.
- b) Using the scale 2 cm to represent 0.1 units on both axes, draw a suitable line graph on the grid provided. Hence estimate the values of K and n.
4. The points which coordinates (5,5) and (-3,-1) are the ends of a diameter of a circle centre A
- Determine:

- (a) The coordinates of A

The equation of the circle, expressing it in form $x^2 + y^2 + ax + by + c = 0$

where a, b, and c are constants each computer sold

5. The figure below is a sketch of the graph of the quadratic function $y = k(x+1)(x-2)$

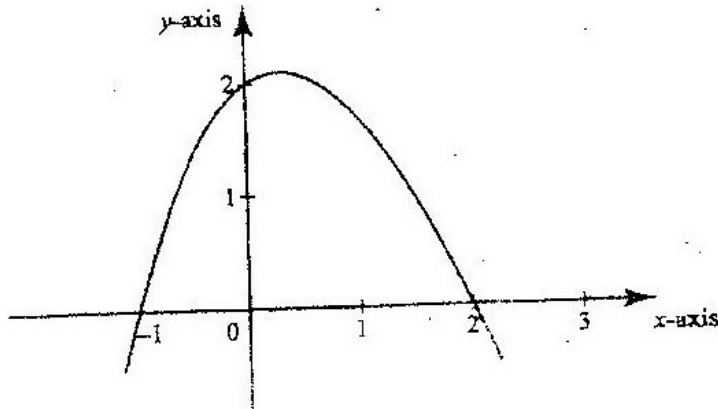

Find the value of k

6. The table below shows the values of the length X (in metres) of a pendulum and the corresponding values of the period T (in seconds) of its oscillations obtained in an experiment.

X (metres)	0.4	1.0	1.2	1.4	1.6
T (seconds)	1.25	2.01	2.19	2.37	2.53

- (a) Construct a table of values of $\log X$ and corresponding values of $\log T$, correcting each value to 2 decimal places
- (b) Given that the relation between the values of $\log X$ and $\log T$ approximate to a linear law of the form $m \log X + \log a$ where a and b are constants
- (i) Use the axes on the grid provided to draw the line of best fit for the

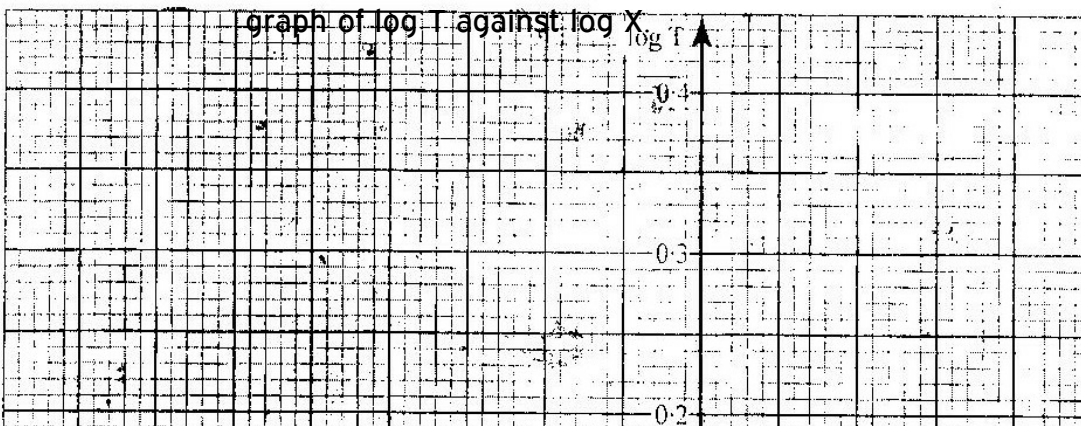

- (ii) Use the graph to estimate the values of a and b
- (iii) Find, to decimal places the length of the pendulum whose period is 1 second.

7. Data collection from an experiment involving two variables x and y was recorded as shown in the table below

X	1.1	1.2	1.3	1.4	1.5	1.6
Y	-0.3	0.5	1.4	2.5	3.8	5.2

The variables are known to satisfy a relation of the form $y = ax^3 + b$ where a and b

are constants

- (a) For each value of x in the table above. Write down the value of x^3
- (b) (i) By drawing a suitable straight line graph, estimate the values of a and

b

(ii) Write down the relationship connecting y and x

8. Two variables x and y , are linked by the relation $y = ax^n$. The figure below shows part of the straight line graph obtained when $\log y$ is plotted against $\log x$.

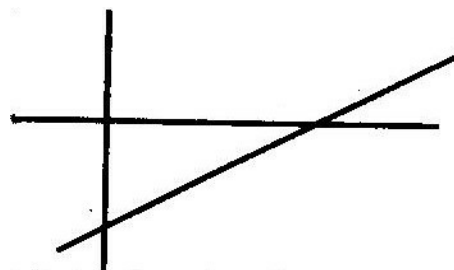

Calculate the value of a and n

9. The luminous intensity I of a lamp was measured for various values of voltage v across it. The results were as shown below

V(volts)	30	36	40	44	48	50	54
L (Lux)	708	1248	1726	2320	3038	3848	4380

It is believed that V and I are related by an equation of the form $I = aV^n$ where a and n are constant.

- (a) Draw a suitable linear graph and determine the values of a and n
- (b) From the graph find
- The value of I when $V = 52$
 - The value of V when $I = 2800$

10. In a certain relation, the value of A and B observe a relation $B = CA + KA^2$ where C and K are constants. Below is a table of values of A and B

A	1	2	3	4	5	6
B	3.2	6.75	10.8	15.1	20	25.2

- (a) By drawing a suitable straight line graphs, determine the values of C and K.
- (b) Hence write down the relationship between A and B
- (c) Determine the value of B when $A = 7$
11. The variables P and Q are connected by the equation $P = ab^q$ where a and b are constants. The value of p and q are given below

P	6.56	17.7	47.8	129	349	941	2540	686
q	0	1	2	3	4	5	6	7

- (a) State the equation in terms of p and q which gives a straight line graph
- (b) By drawing a straight line graph, estimate the value of constants a and b and give your answer correct to 1 decimal place.

FORM FOUR WORK

TOPIC 1

MATRICES AND TRANSFORMATIONS

PAST KCSE QUESTIONS ON THE TOPIC

1. Matrix p is given by $\begin{pmatrix} 1 & 2 \\ 4 & 3 \end{pmatrix}$

- (a) Find P^{-1}
- (b) Two institutions, Elimu and Somo, purchase beans at Kshs. B per bag and maize at Kshs m per bag. Elimu purchased 8 bags of beans and 14 bags of maize for Kshs 47,600. Somo purchased 10 bags of beans and 16 of maize for Kshs. 57,400
- (c) The price of beans later went up by 5% and that of maize remained constant. Elimu bought the same quantity of beans but spent the same total amount of money as before on the two items. State the new ratio of beans to maize.

2. A triangle is formed by the coordinates A (2, 1) B (4, 1) and C (1, 6). It is rotated clockwise through 90° about the origin. Find the coordinates of this image.

3. On the grid provided on the opposite page A (1, 2) B (7, 2) C (4, 4) D (3, 4) is a

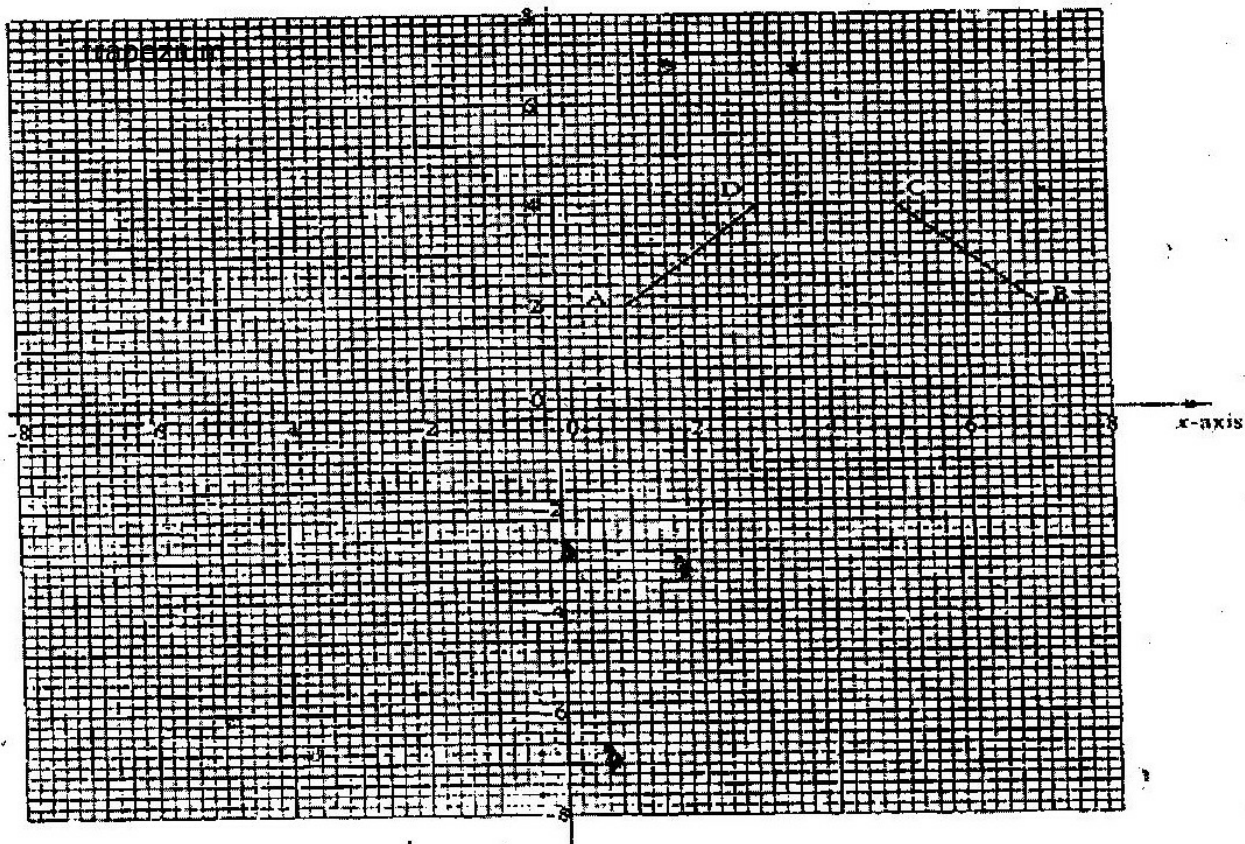

- (a) ABCD is mapped onto A'B'C'D' by a positive quarter turn. Draw the image A'B'C'D' on the grid
- (b) A transformation $\begin{pmatrix} -2 & -1 \\ 0 & 1 \end{pmatrix}$ maps A'B'C'D' onto A''B''C''D''. Find the coordinates of A''B''C''D''

4. A triangle T whose vertices are A (2, 3) B (5, 3) and C (4, 1) is mapped onto triangle T¹ whose vertices are A¹ (-4, 3) B¹ (-1, 3) and C¹ (x, y) by a

Transformation M $\begin{pmatrix} a & b \\ c & d \end{pmatrix}$

- a) Find the: (i) Matrix M of the transformation
(ii) Coordinates of C₁
- b) Triangle T² is the image of triangle T¹ under a reflection in the line y = x.
Find a single matrix that maps T and T₂
5. Triangles ABC is such that A is (2, 0), B (2, 4), C (4, 4) and A''B''C'' is such that A'' is (0, 2), B'' (-4, -10) and C '' is (-4, -12) are drawn on the Cartesian plane

Triangle ABC is mapped onto A''B''C'' by two successive transformations

$$R = \begin{pmatrix} a & b \\ c & d \end{pmatrix} \quad \text{Followed by } P = \begin{pmatrix} 0 & -1 \\ -1 & 0 \end{pmatrix}$$

- (a) Find R
- (b) Using the same scale and axes, draw triangles A'B'C', the image of triangle ABC under transformation R

Describe fully, the transformation represented by matrix R

6. Triangle ABC is shown on the coordinates plane below

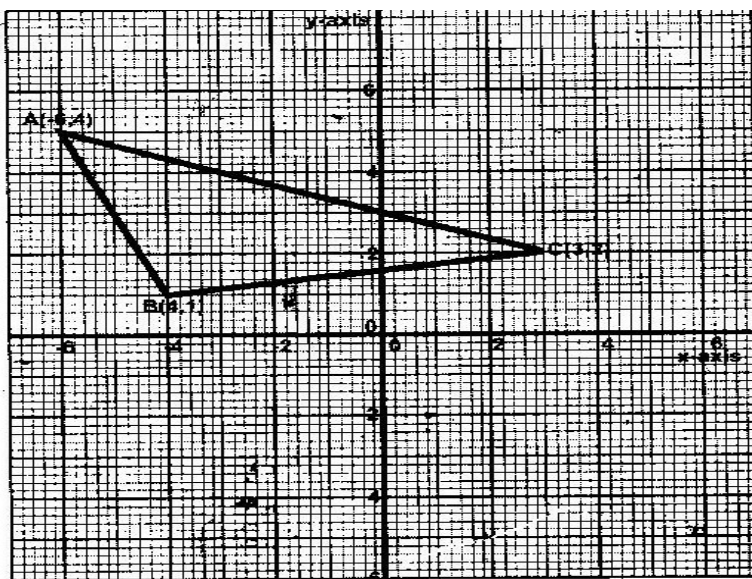

- (a) Given that A (-6, 5) is mapped onto A (6,-4) by a shear with y- axis invariant
- (i) Draw triangle A'B'C', the image of triangle ABC under the shear
- (ii) Determine the matrix representing this shear
- (b) Triangle A B C is mapped on to A'' B'' C'' by a transformation defined by

the matrix $\begin{pmatrix} -1 & 0 \\ 1\frac{1}{2} & -1 \end{pmatrix}$

(i) Draw triangle A'' B'' C''

(ii) Describe fully a single transformation that maps ABC onto A''B'' C''

7. Determine the inverse T^{-1} of the matrix $\begin{pmatrix} 1 & 2 \\ 1 & -1 \end{pmatrix}$

Hence find the coordinates to the point at which the two lines

$$x + 2y = 7 \text{ and } x - y = 1$$

8. Given that $A = \begin{pmatrix} 0 & -1 \\ 3 & 2 \end{pmatrix}$ and $B = \begin{pmatrix} -1 & 0 \\ 2 & -4 \end{pmatrix}$

Find the value of x if

(i) $A - 2x = 2B$

(ii) $3x - 2A = 3B$

(iii) $2A - 3B = 2x$

9. The transformation R given by the matrix

$$A = \begin{pmatrix} a & b \\ c & d \end{pmatrix} \text{ maps } \begin{pmatrix} 17 \\ 0 \end{pmatrix} \text{ to } \begin{pmatrix} 15 \\ 8 \end{pmatrix} \text{ and } \begin{pmatrix} 0 \\ 17 \end{pmatrix} \text{ to } \begin{pmatrix} -8 \\ 15 \end{pmatrix}$$

(a) Determine the matrix A giving a, b, c and d as fractions

(b) Given that A represents a rotation through the origin determine the angle of rotation.

- (c) S is a rotation through 180 about the point (2, 3). Determine the image of (1, 0) under S followed by R.

TOPIC 2

STATISTICS

PAST KCSE QUESTIONS ON THE TOPIC

1. Every week the number of absentees in a school was recorded. This was done for 39 weeks these observations were tabulated as shown below

Number of absentees	0-3	4-7	8-11	12-15	16-19	20-23
(Number of weeks)	6	9	8	11	3	2

Estimate the median absentee rate per week in the school

2. The table below shows high altitude wind speeds recorded at a weather station in a period of 100 days.

Wind speed (knots)	0 - 19	20 - 39	40 - 59	60-79	80- 99	100- 119	120-139	140-159	160-179
Frequency (days)	9	19	22	18	13	11	5	2	1

- (a) On the grid provided draw a cumulative frequency graph for the data
- (b) Use the graph to estimate
- The interquartile range
 - The number of days when the wind speed exceeded 125 knots
3. Five pupils A, B, C, D and E obtained the marks 53, 41, 60, 80 and 56 respectively. The table below shows part of the work to find the standard deviation.

Pupil	Mark x	x - a	(x-a) ²
-------	--------	-------	---------------------

A	53	-5	
B	41	-17	
C	60	2	
D	80	22	
E	56	-2	

- (a) Complete the table
- (b) Find the standard deviation

4. In an agricultural research centre, the length of a sample of 50 maize cobs were measured and recorded as shown in the frequency distribution table below.

Length in cm	Number of cobs
8 – 10	4
11 – 13	7
14 – 16	11
17 – 19	15
20 – 22	8
23 – 25	5

Calculate

- (a) The mean
- (b) (i) The variance
- (ii) The standard deviation
5. The table below shows the frequency distribution of masses of 50 new-born calves in a ranch

Mass (kg)	Frequency
15 – 18	2

19- 22	3
23 – 26	10
27 – 30	14
31 – 34	13
35 – 38	6
39 – 42	2

- (a) On the grid provided draw a cumulative frequency graph for the data
- (b) Use the graph to estimate
- (i) The median mass
 - (ii) The probability that a calf picked at random has a mass lying between 25 kg and 28 kg.

6. The table below shows the weight and price of three commodities in a given period

Commodity	Weight	Price Relatives
X	3	125
Y	4	164
Z	2	140

Calculate the retail index for the group of commodities.

7. The number of people who attended an agricultural show in one day was 510 men, 1080 women and some children. When the information was represented on a pie chart, the combined angle for the men and women was 216° . Find the angle representing the children.
8. The mass of 40 babies in a certain clinic were recorded as follows:

Mass in Kg No. of babies.

1.0 – 1.9	6
2.0 – 2.9	14
3.0 -3.9	10
4.0 – 4.9	7
5.0 – 5.9	2
6.0 – 6.9	1

Calculate

- (a) The inter – quartile range of the data.
 (b) The standard deviation of the data using 3.45 as the assumed mean.

9. The data below shows the masses in grams of 50 potatoes

Mass (g)	25- 34	35-44	45 - 54	55- 64	65 - 74	75-84	85-94
No of potatoes	3	6	16	12	8	4	1

- (a) On the grid provide, draw a cumulative frequency curve for the data
 (b) Use the graph in (a) above to determine
- (i) The 60th percentile mass
 (ii) The percentage of potatoes whose masses lie in the range 53g to 68g
10. The histogram below represents the distribution of marks obtained in a test. The bar marked A has a height of 3.2 units and a width of 5 units. The bar marked B has a height of 1.2 units and a width of 10 units

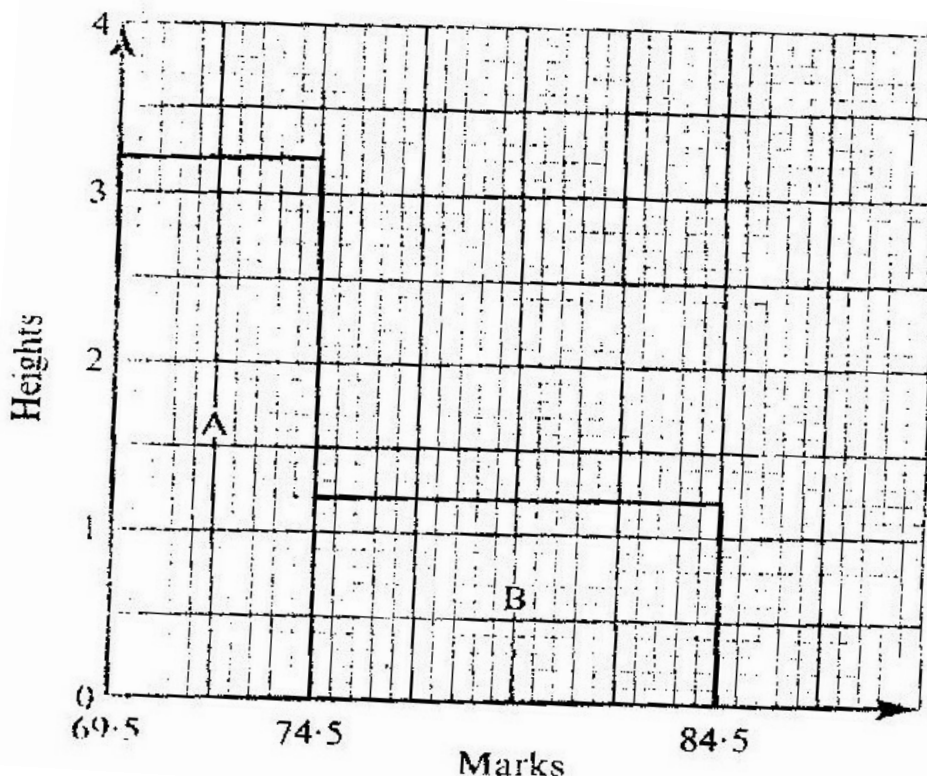

If the frequency of the class represented by bar B is 6, determine the frequency of the class represented by bar A.

11. A frequency distribution of marks obtained by 120 candidates is to be represented in a histogram. The table below shows the grouped marks. Frequencies for all the groups and also the area and height of the rectangle for the group 30 – 60 marks.

Marks	0-10	10-30	30- 60	60-70	70-100
Frequency	12	40	36	8	24
Area of rectangle			180		
Height of rectangle			6		

(a) (i) Complete the table

(ii) On the grid provided below, draw the histogram

(b) (i) State the group in which the median mark lies

(ii) A vertical line drawn through the median mark divides the total area of the histogram into two equal parts

Using this information or otherwise, estimate the median mark

12. In an agriculture research centre, the lengths of a sample of 50 maize cobs were measured and recorded as shown in the frequency distribution table below

Length in cm	Number of cobs
8 – 10	4
11- 13	7
14 – 16	11
17- 19	15
20 – 22	8
23- 25	5

Calculate

(a) The mean

(b) (i) The variance

(ii) The standard deviation

12. The table below shows the frequency distribution of masses of 50 newborn

calves in a ranch.

Mass (kg)	Frequency
15 – 18	2
19- 22	3
23 – 26	10
27 – 30	14
31- 34	13
35 – 38	6
39 - 42	2

- (a) On the grid provided draw a cumulative frequency graph for the data
- (b) Use the graph to estimate
- The median mass
 - The probability that a calf picked at random has a mass lying between 25 kg and 28 kg

14. The table shows the number of bags of sugar per week and their moving averages

Number of bags per week	340	330	x	343	350	34
Moving averages		331	332	y	346	

- (a) Find the order of the moving average
- (b) Find the value of X and Y axis

TOPIC 3

LOC1

PAST KCSE QUESTIONS ON THE TOPIC

1. Using ruler and compasses only, construct a parallelogram ABCD such that $AB = 10\text{cm}$, $BC = 7\text{ cm}$ and $\angle ABC = 105^\circ$. Also construct the loci of P and Q within the parallel such that $AP \leq 4\text{ cm}$, and $BQ \leq 6\text{ cm}$. Calculate the area within the parallelogram and outside the regions bounded by the loci.

2. Use ruler and compasses only in this question

The diagram below shows three points A, B and D

- (a) Construct the angle bisector of acute angle BAD
- (b) A point P, on the same side of AB and D, moves in such a way that $\angle APB = 22\frac{1}{2}^\circ$ construct the locus of P
- (c) The locus of P meets the angle bisector of $\angle BAD$ at C measure $\angle ABC$

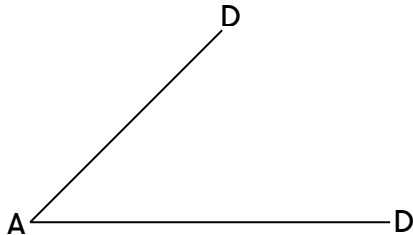

3. Use a ruler and a pair of compasses only for all constructions in this question.
- (a) On the line BC given below, construct triangle $\triangle ABC$ such that $\angle ABC = 30^\circ$ and $BA = 12\text{ cm}$

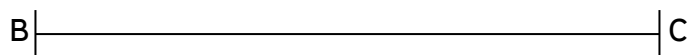

- (b) Construct a perpendicular from A to meet BC produced at D. Measure CD

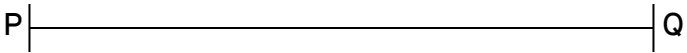
- (c) Construct triangle $A'B'C'$ such that the area of triangle $A'B'C'$ is the three quarters of the area of triangle ABC and on the same side of BC as triangle ABC .
- (d) Describe the locus of A'
4. Use a ruler and compasses in this question. Draw a parallelogram $ABCD$ in which $AB = 8$ cm, $BC = 6$ cm and $\angle BAD = 75^\circ$. By construction, determine the perpendicular distance between AB and CD .
5. In this question use a ruler and a pair of compasses.
- a) Line PQ drawn below is part of a triangle PQR . Construct the triangle PQR in which $\angle QPR = 30^\circ$ and line $PR = 8$ cm
- 
- b) On the same diagram construct triangle PRS such that points S and Q are on the opposite sides of PR such that $PS = PQ$ and $QS = 8$ cm
- c) A point T is on the a line passing through R and parallel to QS . If $\angle QTS = 90^\circ$, locate possible positions of T and label them T_1 and T_2 , Measure the length of T_1T_2 .
6. (a) $ABCD$ is a rectangle in which $AB = 7.6$ cm and $AD = 5.2$ cm. Draw the rectangle and construct the locus of a point P within the rectangle such that P is equidistant from CB and CD (3 marks)
- (b) Q is a variable point within the rectangle $ABCD$ drawn in (a) above such that $60^\circ \leq \angle AQB \leq 90^\circ$
- On the same diagram, construct and show the locus of point Q , by leaving unshaded, the region in which point Q lies.

7. The figure below is drawn to scale. It represents a field in the shape of an equilateral triangle of side 80m

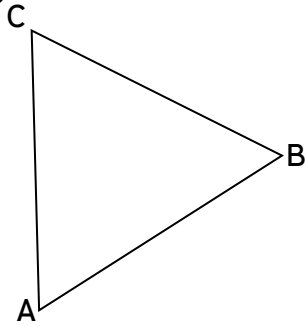

The owner wants to plant some flowers in the field. The flowers must be at most, 60m from A and nearer to B than to C. If no flower is to be more than 40m from BC, show by shading, the exact region where the flowers may be planted.

8. In this question use a ruler and a pair of compasses only

In the figure below, AB and PQ are straight lines

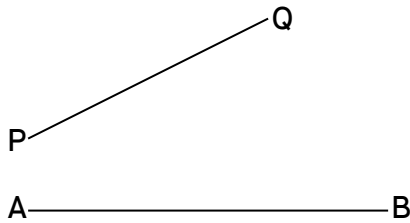

- (a) Use the figure to:
- Find a point R on AB such that R is equidistant from P and Q
 - Complete a polygon PQRST with AB as its line of symmetry and hence measure the distance of R from TS.
- (b) Shade the region within the polygon in which a variable point X must lie given that X satisfies the following conditions
- X is nearer to PT than to PQ
 - RX is not more than 4.5 cm

3. $\angle PXT > 90^\circ$

9. Four points B, C, Q and D lie on same plane. Point B is 42 km due south – west of town Q. Point C is 50 km on a bearing of 560° from Q. Point D is equidistant from B, Q and C.

(a) Using the scale: 1 cm represents 10 km, construct a diagram showing the position of B, C, Q and D

(b) Determine the

(i) Distance between B and C

(ii) Bearing of D from B

10. The diagram below represents a field PQR

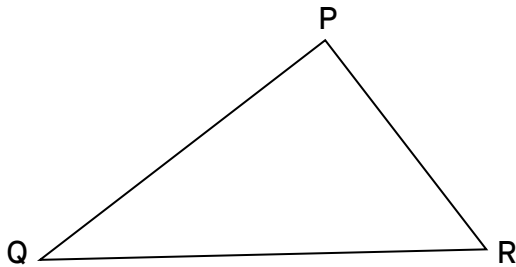

(a) Draw the locus of point equidistant from sides PQ and PR

(b) Draw the locus of points equidistant from points P and R

(c) A coin is lost within a region which is near to point P than R and closer to side PR than to side PQ. Shade the region where the coin can be located.

12. In the figure below, a line XY and three point A,B and C are as given. On the figure construct

- (a) The perpendicular bisector of AB
- (b) A point P on the line XY such that $\angle APB = \angle ACB$

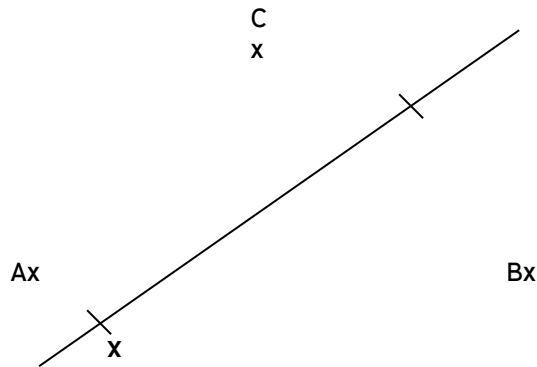

TOPIC 4:

TRIGONOMETRY

PAST KCSE QUESTIONS ON THE TOPIC

1. (a) Complete the table for the function $y = 2 \sin x$

x	0°	10°	20°	30°	40°	50°	60°	70°	80°	90°	100°	110°	120°
Sin	0	0.5000							-				
3x									08660				
y	0	1.00							-1.73				

(b) (i) Using the values in the completed table, draw the graph of

$$y = 2 \sin 3x \text{ for } 0^\circ \leq x \leq 120^\circ \text{ on the grid provided}$$

(ii) Hence solve the equation $2 \sin 3x = -1.5$

2. Complete the table below by filling in the blank spaces

x°	0°	30°	60°	90°	120°	150°	180°	210°	240°	270°	300°	330°	360°
$\cos x^\circ$	1.00		0.50			-0.87		-0.87					
$2 \cos \frac{1}{2} x^\circ$	2.00	1.93				0.52			-1.00				-2.00

Using the scale 1 cm to represent 30° on the horizontal axis and 4 cm to represent 1 unit on the vertical axis draw, on the grid provided, the graphs of $y = \cos x^\circ$ and $y = 2 \cos \frac{1}{2} x^\circ$ on the same axis.

(a) Find the period and the amplitude of $y = 2 \cos \frac{1}{2} x^\circ$

(b) Describe the transformation that maps the graph of $y = \cos x^\circ$ on the graph of $y = 2 \cos \frac{1}{2} x^\circ$

2. (a) Complete the table below for the value of $y = 2 \sin x + \cos x$.

x	0°	30°	45°	60°	90°	120°	135°	150°	180°	225°	270°	315°	360°
2 sin x	0		1.4	1.7	2	1.7	1.4	1	0		-2	-1.4	0
Cos x	1		0.7	0.5	0	-0.5	-0.7	-0.9	-1		0	0.7	1
y	1		2.1	2.2	2	1.2	0.7	0.1	-1		-2	-0.7	1

- (b) Using the grid provided draw the graph of $y=2\sin x + \cos x$ for 0° . Take 1cm represent 30° on the x- axis and 2 cm to represent 1 unit on the axis.
- (c) Use the graph to find the range of x that satisfy the inequalities
 $2 \sin x \cos x > 0.5$
4. (a) Complete the table below, giving your values correct to 2 decimal places.

x	0	10	20	30	40	50	60	70
Tan x	0							
$2x + 300$	30	50	70	90	110	130	150	170
Sin ($2x + 30^\circ$)	0.50			1				

- b) On the grid provided, draw the graphs of $y = \tan x$ and $y = \sin (2x + 30^\circ)$ for $0^\circ \leq x 70^\circ$
- Take scale: 2 cm for 100 on the x- axis
 4 cm for unit on the y- axis

Use your graph to solve the equation $\tan x - \sin (2x + 30^\circ) = 0$.

5. (a) Complete the table below, giving your values correct to 2 decimal places

x°	0	30	60	90	120	150	180
$2 \sin x^\circ$	0	1		2		1	
$1 - \cos x^\circ$			0.5	1			

- (b) On the grid provided, using the same scale and axes, draw the graphs of $y = \sin x^\circ$ and $y = 1 - \cos x^\circ$ for $0 \leq x \leq 180^\circ$

Take the scale: 2 cm for 30° on the x-axis

2 cm for 1 unit on the y-axis

- (c) Use the graph in (b) above to

- (i) Solve equation

$$2 \sin x^\circ + \cos x^\circ = 1$$

- (ii) Determine the range of values x for which $2 \sin x^\circ > 1 - \cos x^\circ$

6. (a) Given that $y = 8 \sin 2x - 6 \cos x$, complete the table below for the missing values of y , correct to 1 decimal place.

x	0°	15°	30°	45°	60°	75°	90°	105°	120°
$y = 8 \sin 2x - 6 \cos x$	-6	-1.8		3.8	3.9	2.4	0		-3.9
$\cos x$									

- (b) On the grid provided, below, draw the graph of $y = 8 \sin 2x - 6 \cos x$ for

$$0^{\circ} \leq x \leq 120^{\circ}$$

Take the scale 2 cm for 15° on the x- axis

2 cm for 2 units on the y – axis

- (c) Use the graph to estimate
- (i) The maximum value of y
 - (ii) The value of x for which $4 \sin 2x - 3 \cos x = 1$
7. Solve the equation $4 \sin (x + 30^{\circ}) = 2$ for $0 \leq x \leq 360^{\circ}$
8. Find all the positive angles not greater than 180° which satisfy the equation
- $$\sin^2 x - 2 \tan x = 0$$
- $\cos x$
9. Solve for values of x in the range $0^{\circ} \leq x \leq 360^{\circ}$ if $3 \cos^2 x - 7 \cos x = 6$
10. Simplify $\frac{9 - y^2}{y}$ where $y = 3 \cos$
11. Find all the values of θ between 0° and 360° satisfying the equation $5 \sin \theta = -4$
12. Given that $\sin (90 - x) = 0.8$. Where x is an acute angle, find without using mathematical tables the value of $\tan x^{\circ}$
13. Complete the table given below for the functions

$y = -3 \cos 2x^{\circ}$ and $y = 2 \sin (\frac{3x}{2}^{\circ} + 30^{\circ})$ for $0 \leq x \leq 180^{\circ}$

x°	0°	20°	40°	60°	80°	100°	120°	140°	160°	180°
$-3\cos 2x^{\circ}$	-3.00	-2.30	-0.52	1.50	2.82	2.82	1.50	-0.52	-2.30	-3.00
$2 \sin (3 x^{\circ} + 30^{\circ})$	1.00	1.73	2.00	1.73	1.00	0.00	-1.00	-1.73	-2.00	-1.73

Using the graph paper draw the graphs of $y = -3 \cos 2x^{\circ}$ and $y = 2 \sin (\frac{3x}{2}^{\circ} + 30^{\circ})$

- (a) On the same axis. Take 2 cm to represent 20° on the x- axis and 2 cm to represent one unit on the y – axis
- (b) From your graphs. Find the roots of $3 \cos 2 x^{\circ} + 2 \sin (\frac{3x}{2}^{\circ} + 30^{\circ}) = 0$

14. Solve the values of x in the range $0^{\circ} \leq x \leq 360^{\circ}$ if $3 \cos^2 x - 7 \cos x = 6$
15. Complete the table below by filling in the blank spaces

x°	0°	30°	60°	90	1°	150°	180	210	24	270	300	330	360
									0				
$\text{Cos}x^{\circ}$	1.00		0.50			-		-					
$2\cos \frac{1}{2} x^{\circ}$	2.00	1.93					0.5						

Using the scale 1 cm to represent 30° on the horizontal axis and 4 cm to represent 1 unit on the vertical axis draw on the grid provided, the graphs of y –

$\cos x^\circ$ and $y = 2 \cos \frac{1}{2} x^\circ$ on the same axis

- (a) Find the period and the amplitude of $y = 2 \cos \frac{1}{2} x^\circ$

Ans. Period = 720° . Amplitude = 2

- (b) Describe the transformation that maps the graph of $y = \cos x^\circ$ on the graph of $y = 2 \cos \frac{1}{2} x^\circ$

TOPIC 5

THREE DIMENSIONAL GEOMETRY

PAST KCSE QUESTIONS ON THE TOPIC

1. The diagram below shows a right pyramid VABCD with V as the vertex. The base of the pyramid is rectangle ABCD, WITH $ab = 4$ cm and $BC = 3$ cm. The height of the pyramid is 6 cm.

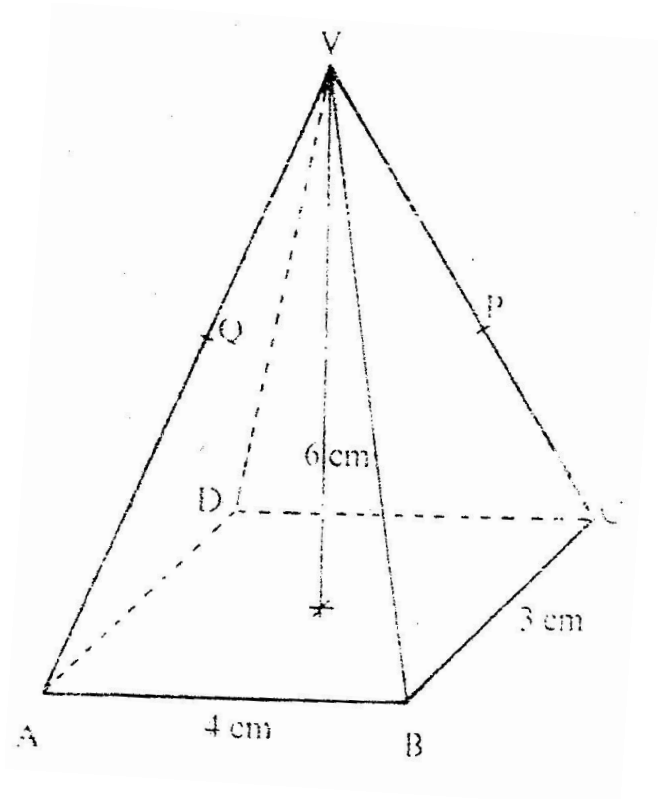

- (a) Calculate the
- (i) Length of the projection of VA on the base
 - (ii) Angle between the face VAB and the base
- (b) P is the mid-point of VC and Q is the mid-point of VD.
Find the angle between the planes VAB and the plane ABPQ

2. The figure below represents a square based solid with a path marked on it.

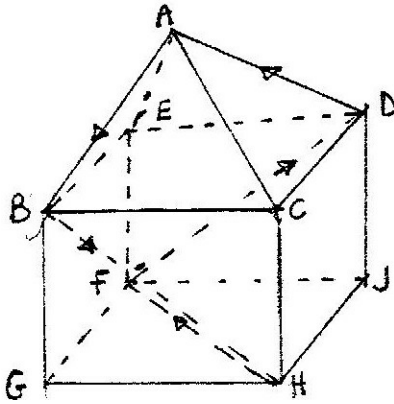

Sketch and label the net of the solid.

3. The diagram below represents a cuboid ABCDEFGH in which $FG = 4.5$ cm, $GH = 8$ cm and $HC = 6$ cm

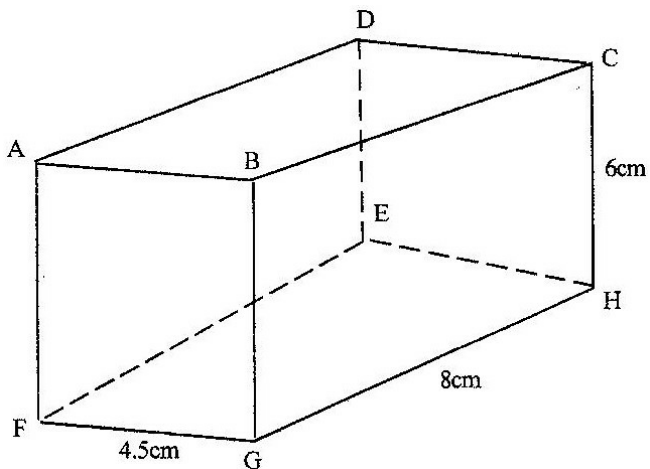

Calculate:

- (a) The length of FC
- (b) (i) The size of the angle between the lines FC and FH
 (ii) The size of the angle between the lines AB and FH
- (c) The size of the angle between the planes ABHE and the plane FGHE
4. The base of a right pyramid is a square ABCD of side $2a$ cm. The slant edges VA, VB, VC and VD are each of length $3a$ cm.
- (a) Sketch and label the pyramid
- (b) Find the angle between a slanting edge and the base
5. The triangular prism shown below has the sides $AB = DC = EF = 12$ cm. the ends are equilateral triangles of sides 10cm. The point N is the mid point of FC.

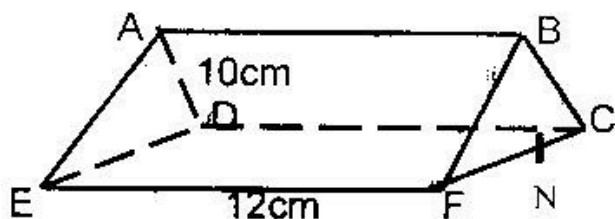

Find the length of:

- (a) (i) BN
 (ii) EN
- (b) Find the angle between the line EB and the plane CDEF

TOPIC 6:

LATITUDES AND LONGITUDES

PAST KCSE QUESTIONS ON THE TOPIC

1. An aeroplane flies from point A ($1^{\circ} 15' S, 37^{\circ} E$) to a point B directly North of A. the arc AB subtends an angle of 45° at the center of the earth. From B, aeroplanes flies due west two a point C on longitude $23^{\circ} W$.)

(Take the value of $n^{22}/7$ as and radius of the earth as 6370km)

- (a) (i) Find the latitude of B
(ii) Find the distance traveled by the aeroplane between B and C
- (b) The aeroplane left at 1.00 a.m local time. When the aeroplane was leaving B, hat was the local time at C?
2. The position of two towns X and Y are given to the nearest degree as X ($45^{\circ} N, 10^{\circ} W$) and Y ($45^{\circ} N, 70^{\circ} W$)

Find

- (a) The distance between the two towns in
(i) Kilometers (take the radius of the earth as 6371)
(ii) Nautical miles (take 1 nautical mile to be 1.85 km)
- (b) The local time at X when the local time at Y is 2.00 pm.
3. A plane leaves an airport A ($38.5^{\circ} N, 37.05^{\circ} W$) and flies dues North to a point B on latitude $52^{\circ} N$.
- (a) Find the distance covered by the plane
- (b) The plane then flies due east to a point C, 2400 km from B. Determine the position of C
- Take the value n of as $n^{22}/7$ and radius of the earth as 6370 km
4. A plane flying at 200 knots left an airport A ($30^{\circ} S, 31^{\circ} E$) and flew due North to an airport B ($30^{\circ} N, 31^{\circ} E$)

- (a) Calculate the distance covered by the plane, in nautical miles
- (b) After a 15 minutes stop over at B, the plane flew west to an airport C (30° N, 13° E) at the same speed.

Calculate the total time to complete the journey from airport C, through airport B.

5. Two towns A and B lie on the same latitude in the northern hemisphere.

When its 8 am at A, the time at B is 11.00 am.

- a) Given that the longitude of A is 15° E find the longitude of B.
- b) A plane leaves A for B and takes $3\frac{1}{2}$ hours to arrive at B traveling along a parallel of latitude at 850 km/h. Find:
- (i) The radius of the circle of latitude on which towns A and B lie.
- (ii) The latitude of the two towns (take radius of the earth to be 6371 km)

6. Two places A and B are on the same circle of latitude north of the equator. The longitude of A is 118° W and the longitude of B is 133° E. The shorter distance between A and B measured along the circle of latitude is 5422 nautical miles.

Find, to the nearest degree, the latitude on which A and B lie

7. (a) A plane flies by the short estimate route from P (10° S, 60° W) to Q (70° N, 120° E) Find the distance flown in km and the time taken if the average speed is 800 km/h.
- (b) Calculate the distance in km between two towns on latitude 50° S with longitudes and 20° W. (take the radius of the earth to be 6370 km)

8. Calculate the distance between M (30°N , 36°E) and N (30°N , 144°W) in nautical miles.
- (i) Over the North Pole
 - (ii) Along the parallel of latitude 30°N
9. (a) A ship sailed due south along a meridian from 12°N to $10^{\circ}30'\text{S}$. Taking the earth to be a sphere with a circumference of 4×10^4 km, calculate in km the distance traveled by the ship.
- (b) If a ship sails due west from San Francisco ($37^{\circ} 47'\text{N}$, $122^{\circ} 26'\text{W}$) for distance of 1320 km. Calculate the longitude of its new position (take the radius of the earth to be 6370 km and $\pi = 22/7$).

TOPIC 7

LINEAR PROGRAMMING

PAST KCSE QUESTIONS ON THE TOPIC

1. A school has to take 384 people for a tour. There are two types of buses available, type X and type Y. Type X can carry 64 passengers and type Y can carry 48 passengers. They have to use at least 7 buses.
- (a) Form all the linear inequalities which will represent the above information.
 - (b) On the grid [provide, draw the inequalities and shade the unwanted region.
 - (c) The charges for hiring the buses are

Type X: Kshs 25,000

Type Y Kshs 20,000

Use your graph to determine the number of buses of each type that should be hired to minimize the cost.

2. An institute offers two types of courses technical and business courses. The institute has a capacity of 500 students. There must be more business students than technical students but at least 200 students must take technical courses. Let x represent the number of technical students and y the number of business students.

(a) Write down three inequalities that describe the given conditions

(b) On the grid provided, draw the three inequalities

(c) If the institute makes a profit of Kshs 2, 500 to train one technical students and Kshs 1,000 to train one business student, determine

(i) The number of students that must be enrolled in each course to maximize the profit

(ii) The maximum profit.

3. A draper is required to supply two types of shirts A and type B.

The total number of shirts must not be more than 400. He has to supply more type A than of type B however the number of types A shirts must be more than 300 and the number of type B shirts not be less than 80.

Let x be the number of type A shirts and y be the number of types B shirts.

(a) Write down in terms of x and y all the linear inequalities representing the information above.

(b) On the grid provided, draw the inequalities and shade the unwanted regions

(c) The profits were as follows

Type A: Kshs 600 per shirt

Type B: Kshs 400 per shirt

- (i) Use the graph to determine the number of shirts of each type that should be made to maximize the profit.
- (ii) Calculate the maximum possible profit.

4. A diet expert makes up a food production for sale by mixing two ingredients N and S. One kilogram of N contains 25 units of protein and 30 units of vitamins. One kilogram of S contains 50 units of protein and 45 units of vitamins. The food is sold in small bags each containing at least 175 units of protein and at least 180 units of vitamins. The mass of the food product in each bag must not exceed 6kg. If one bag of the mixture contains x kg of N and y kg of S

(a) Write down all the inequalities, in terms of x and y representing the information above (2 marks)

(b) On the grid provided draw the inequalities by shading the unwanted regions (2 marks)

(c) If one kilogram of N costs Kshs 20 and one kilogram of S costs Kshs 50, use the graph to determine the lowest cost of one bag of the mixture.

5. Mwanjoki flying company operates a flying service. It has two types of aeroplanes. The smaller one uses 180 litres of fuel per hour while the bigger one uses 300 litres per hour.

The fuel available per week is 18,000 litres. The company is allowed 80 flying hours per week.

(a) Write down all the inequalities representing the above information

(b) On the grid provided on page 21, draw all the inequalities in (a) above by shading the unwanted regions

(c) The profits on the smaller aeroplane is Kshs 4000 per hour while that on the bigger one is Kshs. 6000 per hour. Use your graph to determine the maximum profit that the company made per week.

6. A company is considering installing two types of machines. A and B. The information about each type of machine is given in the table below.

Machine	Number of operators	Floor space	Daily profit
A	2	5m ²	Kshs 1,500
B	5	8m ²	Kshs 2,500

The company decided to install x machines of types A and y machines of type B

(a) Write down the inequalities that express the following conditions

- i. The number of operators available is 40
- ii. The floor space available is 80m²
- iii. The company is to install not less than 3 type of A machine
- iv. The number of type B machines must be more than one third the number of type A machines

(b) On the grid provided, draw the inequalities in part (a) above and shade the unwanted region.

(c) Draw a search line and use it to determine the number of machines of

each

type that should be installed to maximize the daily profit.

TOPIC 8:

CALCULUS

PAST KCSE QUESTIONS ON THE TOPIC

- The shaded region below represents a forest. The region has been drawn to scale where 1 cm represents 5 km. Use the mid – ordinate rule with six strips to estimate the area of forest in hectares. (4 marks)

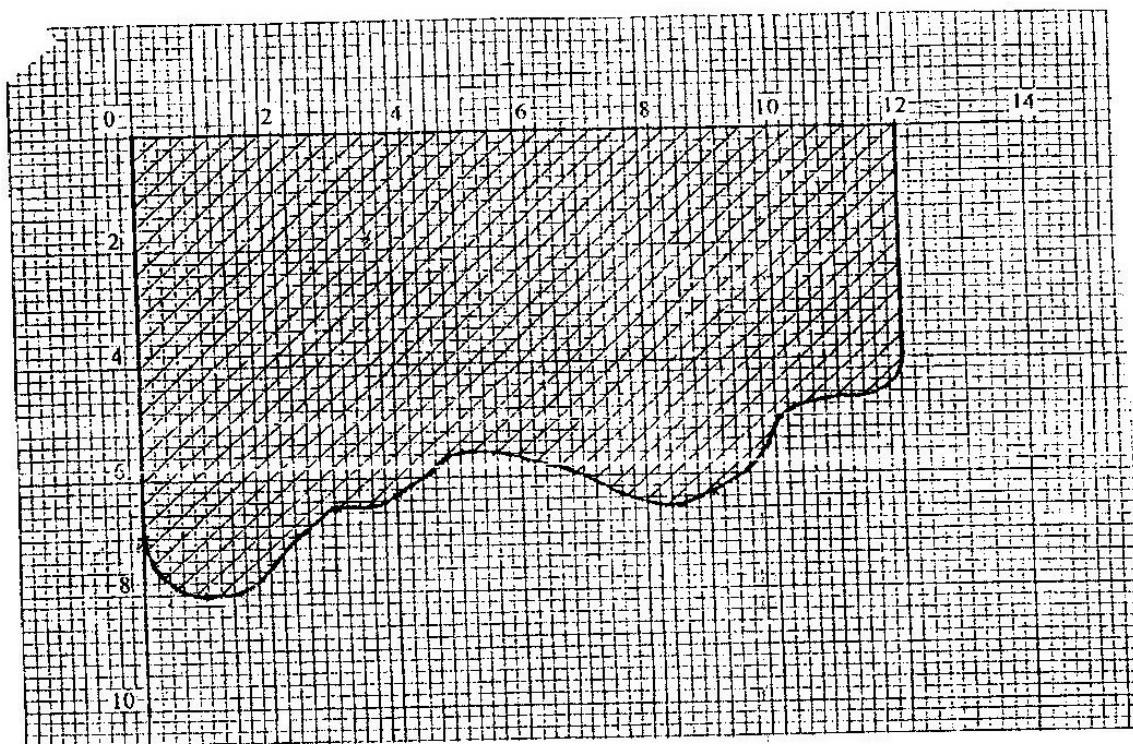

- Find the area bounded by the curve $y=2x^3 - 5$, the x-axis and the lines $x=2$ and $x=4$.

3. Complete the table below for the function $y = 3x^2 - 8x + 10$. (1mk)

x	0	2	4	6	8	10
y	10	6		76		230

Using the values in the table and the trapezoidal rule, estimate the area bounded by the curve $y = 3x^2 - 8x + 10$ and the lines $y=0$, $x=0$ and $x=10$.

4. Use the trapezoidal rule with intervals of 1 cm to estimate the area of the shaded region below.

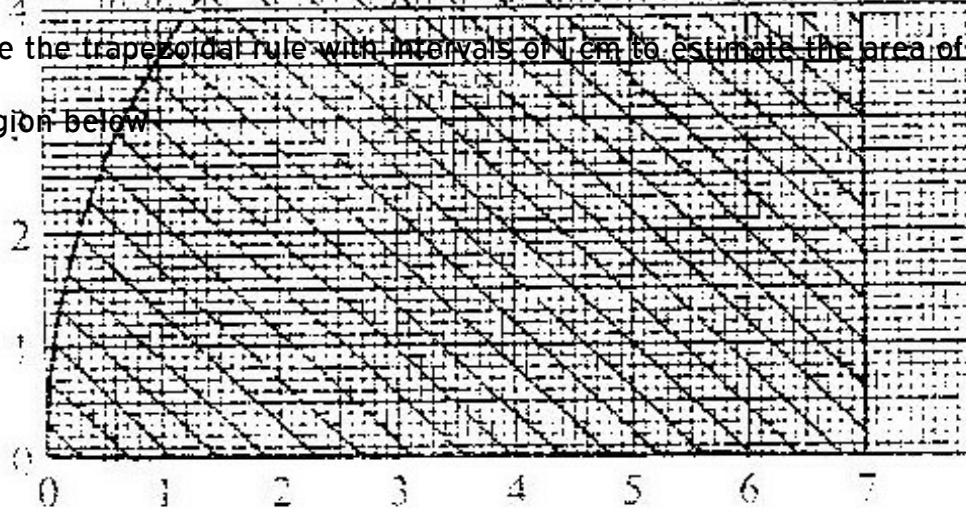

5. (a) Find the value of x at which the curve $y = x - 2x^2 - 3$ crosses the x -axis
- (b) Find $\int (x^2 - 2x - 3) dx$
- (c) Find the area bounded by the curve $y = x^2 - 2x - 3$, the axis and the lines $x = 2$ and $x = 4$.

6. The graph below consists of a non-quadratic part ($0 \leq x \leq 2$) and a quadratic part ($2 \leq x \leq 8$). The quadratic part is $y = x^2 - 3x + 5$, $2 \leq x \leq 8$

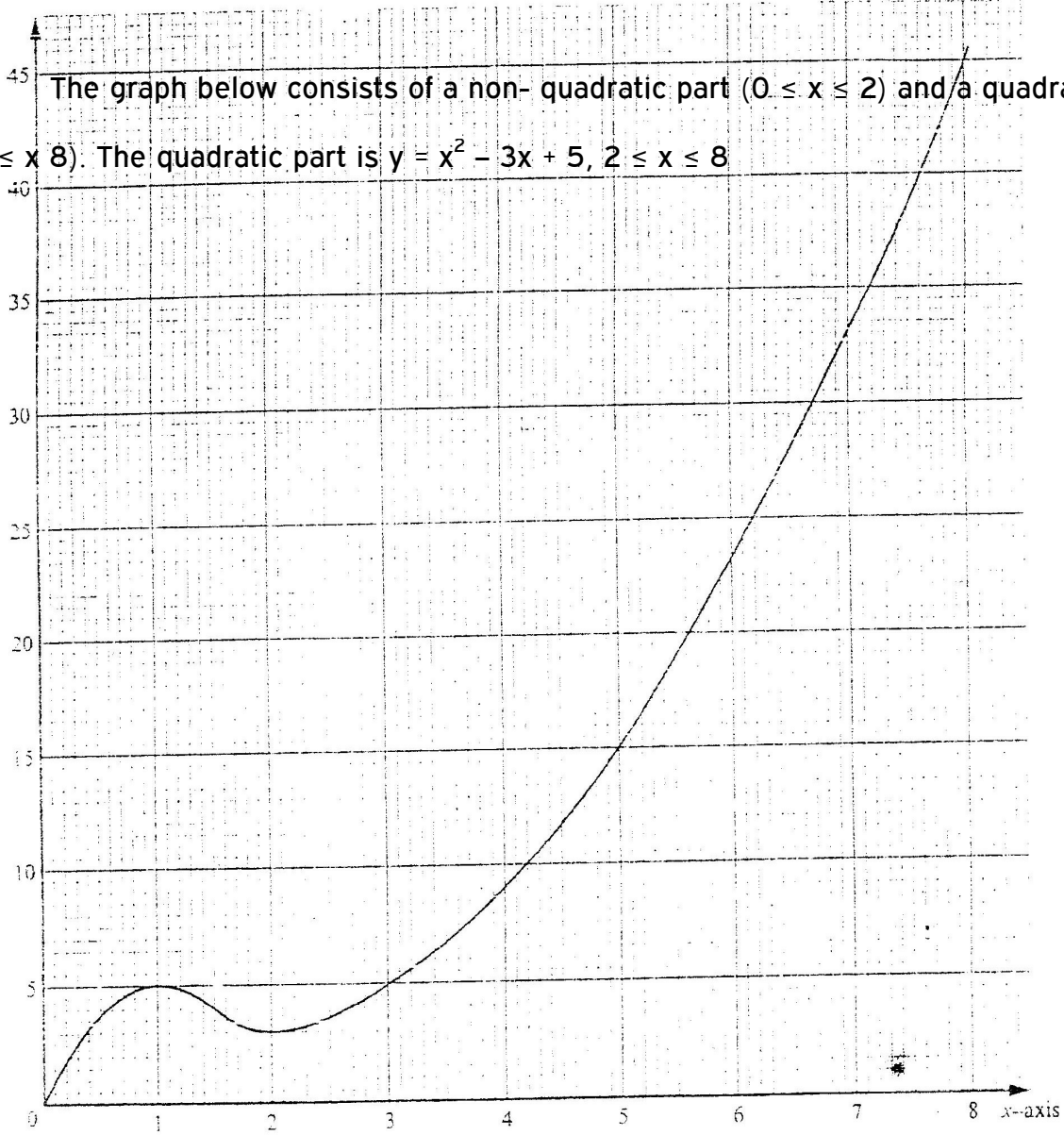

- (a) Complete the table below

x	2	3	4	5	6	7	8
y	3						

(1mk)

(b) Use the trapezoidal rule with six strips to estimate the area enclosed by the

curve, x = axis and the line x = 2 and x = 8 (3mks)

(c) Find the exact area of the region given in (b) (3mks)

(d) If the trapezoidal rule is used to estimate the area under the curve between

x = 0 and x = 2, state whether it would give an under- estimate or an over- estimate. Give a reason for your answer.

7. Find the equation of the gradient to the curve $Y = (x^2 + 1)(x - 2)$ when $x = 2$

8. The distance from a fixed point of a particular in motion at any time t seconds is given by

$$S = t^3 - 5t^2 + 2t + 5$$

$$2t^2$$

Find its:

(a) Acceleration after 1 second

(b) Velocity when acceleration is Zero

9. The curve of the equation $y = 2x + 3x^2$, has x = -2/3 and x = 0 and x intercepts.

The area bounded by the axis x = -2/3 and x = 2 is shown by the sketch below.

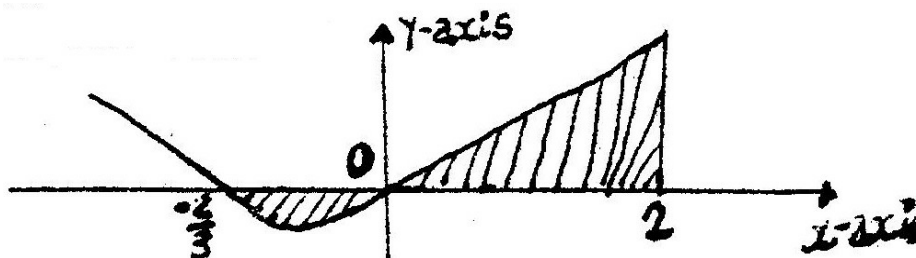

Find:

(a) $(2x + 3x^2) dx$

(b) The area bounded by the curve x – axis, $x = -\frac{2}{3}$ and $x = 2$

10. A particle is projected from the origin. Its speed was recorded as shown in the table below

Time (sec)	0	5	10	15	20	25	30	35
Speed (m/s)	0	2.1	5.3	5.1	6.8	6.7	4.7	2.6

Use the trapezoidal rule to estimate the distance covered by the particle within the 35 seconds.

11. (a) The gradient function of a curve is given by $\frac{dy}{dx} = 2x^2 - 5$

Find the equation of the curve, given that $y = 3$, when $x = 2$

- (b) The velocity, v m/s of a moving particle after seconds is given:

$v = 2t^3 + t^2 - 1$. Find the distance covered by the particle in the interval $1 \leq t \leq 3$

12. Given the curve $y = 2x^3 + \frac{1}{2}x^2 - 4x + 1$. Find the:

- i) Gradient of curve at $\{1, -\frac{1}{2}\}$

isabokemicah@gmail.com

ii) Equation of the tangent to the curve at $\{1, -\frac{1}{2}\}$

13. The diagram below shows a straight line intersecting the curve $y = (x-1)^2 + 4$ at the points P and Q. The line also cuts x-axis at (7, 0) and y axis at (0, 7)

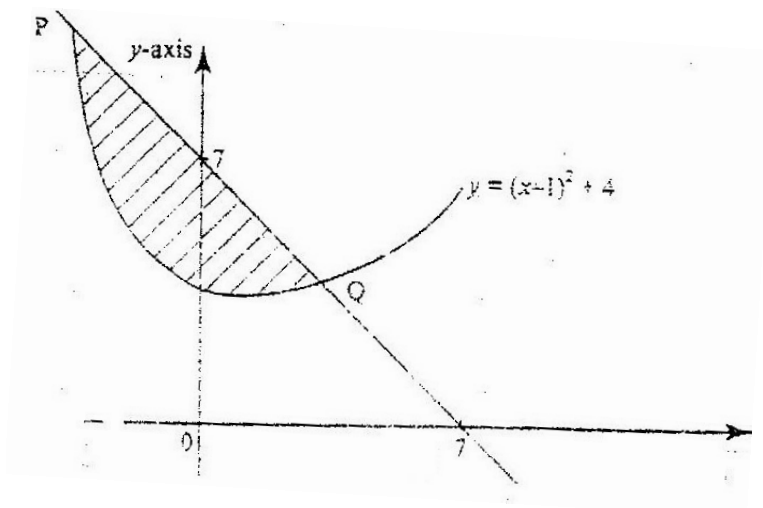

- Find the equation of the straight line in the form $y = mx + c$.
 - Find the coordinates of p and Q.
 - Calculate the area of the shaded region.
14. The acceleration, a ms^{-2} , of a particle is given by $a = 25 - 9t^2$, where t in seconds after the particle passes fixed point O.

If the particle passes O, with velocity of 4 ms^{-1} , find

- An expression of velocity V, in terms of t
 - The velocity of the particle when $t = 2$ seconds
15. A curve is represented by the function $y = \frac{1}{3}x^3 + x^2 - 3x + 2$
- Find: $\frac{dy}{dx}$
 - Determine the values of y at the turning points of the curve
 $y = \frac{1}{3}x^3 + x^2 - 3x + 2$
 - In the space provided below, sketch the curve of $y = \frac{1}{3}x^3 + x^2 - 3x + 2$

16. A circle centre O, has the equation $x^2 + y^2 = 4$. The area of the circle in the first quadrant is divided into 5 vertical strips of width 0.4 cm

- (a) Use the equation of the circle to complete the table below for values of y correct to 2 decimal places

X	0	0.4	0.8	1.2	1.6	2.0
Y	2.00			1.60		0

- (b) Use the trapezium rule to estimate the area of the circle

17. A particle moves along straight line such that its displacement S metres from a given point is $S = t^3 - 5t^2 + 4$ where t is time in seconds

Find

- (a) The displacement of particle at $t = 5$
- (b) The velocity of the particle when $t = 5$
- (c) The values of t when the particle is momentarily at rest
- (d) The acceleration of the particle when $t = 2$

18. The diagram below shows a sketch of the line $y = 3x$ and the curve $y = 4 - x^2$ intersecting at points P and Q.

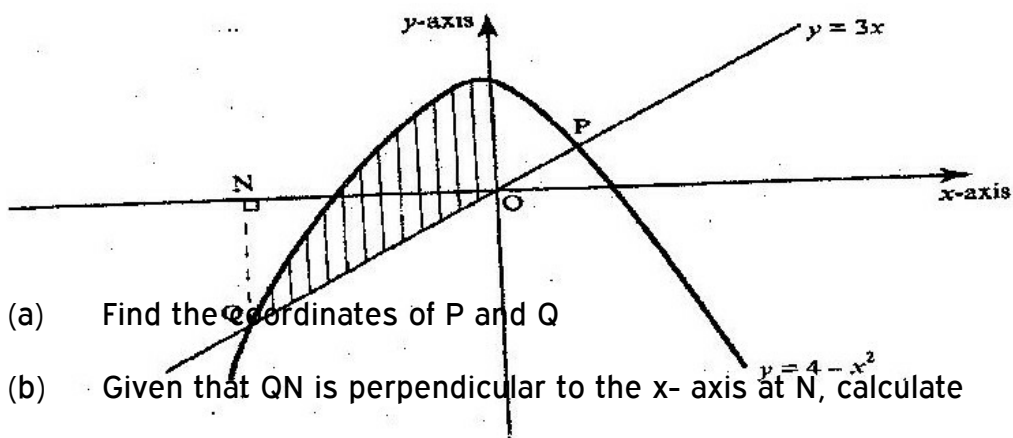

- (a) Find the coordinates of P and Q
- (b) Given that QN is perpendicular to the x-axis at N, calculate

- (i) The area bounded by the curve $y = 4 - x^2$, the x- axis and the line QN (2 marks)
- (ii) The area of the shaded region that lies below the x- axis
- (iii) The area of the region enclosed by the curve $y = 4-x^2$, the line $y - 3x$ and the y-axis.

2007

19. The gradient of the tangent to the curve $y = ax^3 + bx$ at the point (1, 1) is -5
Calculate the values of a and b.

2007

20. The diagram on the grid below represents as extract of a survey map showing two adjacent plots belonging to Kazungu and Ndoe.

The two dispute the common boundary with each claiming boundary along different smooth curves coordinates (x, y) and (x, y₂) in the table below, represents points on the boundaries as claimed by Kazungu Ndoe respectively.

x	0	1	2	3	4	5	6	7	8	9
y ₁	0	4	5.7	6.9	8	9	9.8	10.6	11.3	12
y ₂	0	0.2	0.6	1.3	2.4	3.7	5.3	7.3	9.5	12

- (a) On the grid provided above draw and label the boundaries as claimed by Kazungu and Ndoe.
- (b) (i) Use the trapezium rule with 9 strips to estimate the area of the section of the land in dispute

- (ii) Express the area found in b (i) above, in hectares, given that 1 unit on each axis represents 20 metres

21. The gradient function of a curve is given by the expression $2x + 1$. If the curve passes through the point $(-4, 6)$;

(a) Find:

(i) The equation of the curve

(ii) The vales of x , at which the curve cuts the x - axis

(b) Determine the area enclosed by the curve and the x - axis

22. A particle moves in a straight line through a point P. Its velocity v m/s is given by $v = 2 - t$, where t is time in seconds, after passing P. The distance s of the particle from P when $t = 2$ is 5 metres. Find the expression for s in terms of t .

23. Find the area bonded by the curve $y = 2x - 5$ the x -axis and the lines $x = 2$ and $x = 4$.

23. Complete the table below for the function

$$Y = 3x^2 - 8x + 10$$

X	0	2	4	6	8	10
Y	10	6	-	70	-	230

Using the values in the table and the trapezoidal rule, estimate the area bounded by the curve $y = 3x^2 - 8x + 10$ and the lines $y = 0$, $x = 0$ and $x = 10$

24. (a) Find the values of x which the curve $y = x^2 - 2x - 3$ crosses the axis
 (b) Find $(x^2 - 2x - 3) dx$

- (c) Find the area bounded by the curve $Y = x^2 - 2x - 3$. The x - axis and the lines $x = 2$ and $x = 4$

25. Find the equation of the tangent to the curve $y = (x + 1)(x - 2)$ when $x = 2$

26. The distance from a fixed point of a particle in motion at any time t seconds is given by $s = t - \frac{5}{2}t^2 + 2t + s$ metres

Find its

- (a) Acceleration after t seconds
(b) Velocity when acceleration is zero
27. The curve of the equation $y = 2x + 3x^2$, has $x = -\frac{2}{3}$ and $x = 0$, as x intercepts. The area bounded by the curve, x - axis, $x = -\frac{2}{3}$ and $x = 2$ is shown by the sketch below.

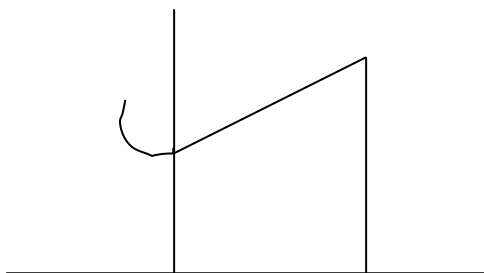

- (a) Find $\int(2x + 3x^2) dx$
(b) The area bounded by the curve, x axis $x = -\frac{2}{3}$ and $x = 2$
28. A curve is given by the equation $y = 5x^3 - 7x^2 + 3x + 2$
- Find the
- (a) Gradient of the curve at $x = 1$

- (b) Equation of the tangent to the curve at the point (1, 3)
29. The displacement x metres of a particle after t seconds is given by $x = t^2 - 2t + 6$,
 $t > 0$
- (a) Calculate the velocity of the particle in m/s when $t = 2$ s
- (b) When the velocity of the particle is zero,
Calculate its
- (i) Displacement
- (ii) Acceleration
30. The displacement s metres of a particle moving along a straight line after t seconds is given by $s = 3t + \frac{3}{2}t^2 - 2t^3$
- (a) Find its initial acceleration
- (b) Calculate
- (i) The time when the particle was momentarily at rest.
- (ii) Its displacement by the time it comes to rest momentarily when
 $t = 1$ second, $s = 1 \frac{1}{2}$ metres when $t = \frac{1}{2}$ seconds
- (c) Calculate the maximum speed attained

For marking schemes

isabokemicah@gmail.com

call 0705525657