

CHEMISTRY

KCSE QUICK REVISION

FOR MORE SIMPLIFIED RESOURCES

CALL Mr Isaboke 0705525657

CONTENTS

1. SIMPLE CLASSIFICATION OF SUBSTANCES
2. THE ATMOSPHERE AND ITS COMBUSTION
3. WATER AND HYDROGEN
4. ACIDS, BASES AND SALTS
5. PERIODIC TABLE AND ITS DERIVATIVES (e.g. structure and bonding)
6. MOLE CONCEPT IN GENERAL
7. CARBON AND ITS DERIVATIVES
8. NITROGEN AND ITS DERIVATIVES
9. SULPHUR AND ITS DERIVATIVES
10. CHLORINE AND ITS DERIVATIVES

ELECTROCHEMISTRY

- 11. REVERSIBLE REACTIONS AND REACTION RATES
- 12. THERMOCHEMISTRY
- 13. INDUSTRIAL CHEMISTRY (INDUSTRIAL PROCESSES)
- 14. METALS (extraction, purification and uses)
- 15. ORGANIC CHEMISTRY
- 16. RADIOACTIVITY

SIMPLE CLASSIFICATION OF SUBSTANCES

ATMOSPHERE AND ITS COMBUSTION

1. Against each mixture write down suitable methods of separation.

- (a) Coloured extracts of grass dissolved in ethanol. A - Paper chromatography.
- (b) Kerosine from Crude oil. A - Fractional distillation
- (c) Paraffin from water. A separating funnel
- (d) Iron filings from Sulphur powder. A - magnet
- (e) Ammonium chloride from Sodium chloride. A - sublimation
- (f) Seawater, to obtain salt. A - Evaporation.
- (g) Blue Copper Sulphate crystals from aqueous copper sulphate. A- Crystallisation - some of the water must be evaporated for crystals to form on cooling the saturated solution to room temperature.

2. Why is fractional distillation suitable for separating crude oil constituents?

A - Because these components have close and different boiling points.

3. Monica a form one student decides to separate powdered calcium carbonate from powdered calcium chloride by shaking the mixture with water and then filtering. Would this procedure succeed? Explain your answer.

A - This procedure would succeed. Calcium carbonate is insoluble in water whereas calcium chloride is very soluble. On filtering the mixture, calcium carbonate would remain on the filter paper whereas calcium chloride solution would pass through.

4. What does distillation mean and what is its importance in chemistry.

A - Distillation occurs when a liquid is heated to form a vapour which is then condensed to reform the liquid. It is an important process in chemistry since it provides a means of purifying liquids.

5. Here is a chromatograph of 3 dyes. Which one of them is not a pure dye?



A

B

C



A

B

C

6. Name

(a) Cleansing agents for removing these stains from your school dress:

(i) Oily and greasy – A – Acetone

(ii) Blood stains – A – Ammonia

(iii) Perspiration stains – A – Ammonia

(b) A drying agent for ammonia gas – A – calcium oxide

(c) A solvent for paint – A – Benzene

(d) A gas which cannot be collected over water – A – Ammonia

(e) A solid that sublimes – A – Iodine.

7. The following represents a paper chromatogram of pure substances P , Q , R , S and a mixture W. Which of the pure substances are in the mixture W?

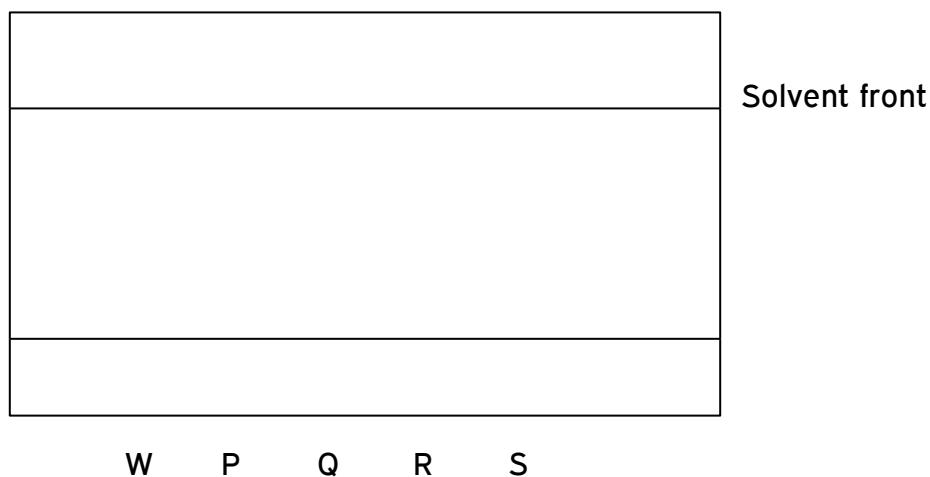

ANS – P and R

8. What do you understand by a saturated solution?

A – This is the solution that can't dissolve any more of the solute at a given temperature.

9. What method can be used to obtain pure crystals from a soluble solid with impurities?

A – Recrystallisation

10. Outline how liquid is dried.

A – A liquid is dried by allowing it to remain in contact with the solid drying agent with which it does not react e.g.

(i) Traces of water can be removed from ethanol by standing it over quicklime.

(ii) Chloroform, diethylene ether can be dried by using anhydrous sodium sulphate.

11. What do impurities do to both Boiling points and melting points of substances?

A – Impurities will lower the melting point of substance, while boiling will either increase or drop depending on the type of impurity.

12. What do you understand by solvent extraction in separation of mixtures?

A – This is the separation of a mixture where a solvent is used because certain

components of the mixture are soluble in this solvent.

13. State how chromatography is applied in real life situation.

A – Chromatography is used to identify substances as well to separate them. For example, a dye used in feed colouring can be identified by chromatographing it alongside known dyes. If they travel at the same rates in a solvent then the food dye is safe. In this way a chemist can find out whether a dye used in our food is a permitted one or an illegal one.

14. When fine chalk is suspended in water and viewed through a microscope the chalk particles appear to move in a random fashion. This motion is a result of;

A – Bombardment of chalk particles by water particles.

15. An increase in temperature causes an increase in the pressure of a gas because;

A – It increases the average velocity of the particles.

16. Crude oil can be separated by fractional distillation because its constituents;

A – Have different boiling points.

17. Where in Kenya is Crystallization method used. State what happens briefly.

A – This method is used in Lake Magadi to get trona and common salt.

Crystals of the salts are formed when a saturated solution is left exposed to the air for some time. As the evening approaches, drastic change of temperatures have a cooling effect on the saturated solution of the salts. This results into crystal formation.

18. The time – temperature graph obtained when ice was heated to its boiling point is given below.

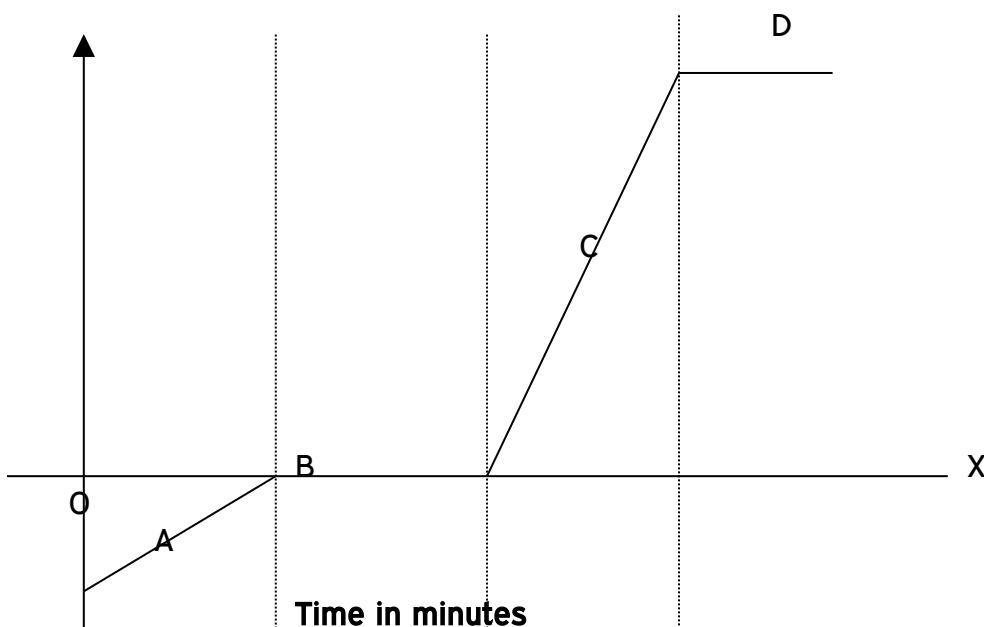

(i) Describe the changes along regions A, B, C and D.

A – Region A – shows ice becoming warm from below 0°C .

B – shows that the temperature remains 0°C as all the ice melts

C – shows water becoming hotter from 0°C to 100°C when it begins to boil.

D – shows water boiling and the temperature remains constant.

(ii) Explain why both B and D levelled off?

A – In B and D regions, the heat supplied is being used to bring about the change in structure from one physical state to another and so the temperature does not rise.

19. Describe briefly how filtration is applied industrially.

A

- (i) A vacuum – cleaner filters dust from the air. The dust particles are trapped in a fabric or paper bag, while the purified air passes through it.
- (ii) In water works, water is filtered before it is pumped to the consumers. This is done by employing simple filtration. Water is allowed to seep through a filter bed of fine sand and gravel in order to remove small particles from it.
- (iii) In the car engine oil is filtered before use.

20. A local brewer at Tarasaa village added water to ethanol and this is all what he had for his customers.

Briefly describe an experiment that you can carry out to help this brewer.

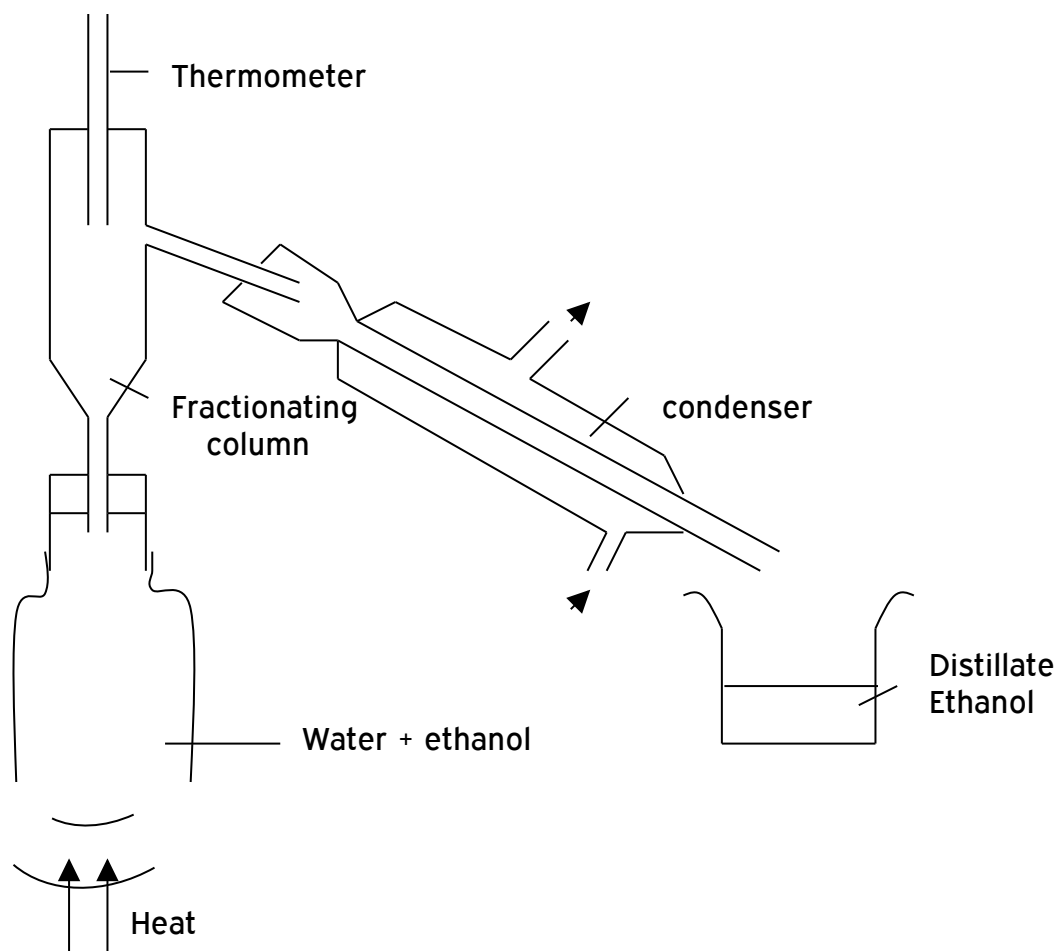

- The above method is fractional distillation, where the differences in the boiling points of the two liquids is used. When the mixture distilled, the liquid with lower boiling point boils out first and is collected.

21. Explain why you can't use concentrated Sulphuric acid and anhydrous calcium chloride to dry ammonia gas.

A



(ii) Ammonia gas forms a complex compound with anhydrous calcium chloride



22.

GAS	Colour physical effect	Solubility in water	Density compared with air	Reaction with Conc. Sulphuric acid
A	Poisonous	Insoluble	Less dense	No reaction
B	Pleasant	Slightly	More dense	No reaction
C	Choking smell	Very soluble	Less dense	Forms salt Yes
D		Insoluble	Little more	No reaction
E	Rotten eggs poisons	Slightly	Heavier	Reacts Yes
F	Pungent	Soluble	More dense	No reaction

- (a) Which of the above gases would you collect over water in the laboratory?
A – B, D & E
- (b) Which of the above gases would you collect over water in a fume cupboard?
A – A
- (c) Which gas would you collect by (i) cupboard delivery (ii) downward delivery?
A – (i) A & C
(ii) B, D, E, & F
- (d) Name the drying agent for gas C and identify the gas.
– Dried using quicklime CaO
– The gas is ammonia (NH₃)
- (e) Which of these gases would you dry by passing through concentrated sulphuric acid?
A – A, B, D & F

23. Distinguish between physical and chemical changes.

ANS - PHYSICAL CHANGE	CHEMICAL CHANGE
1. No new substance formed	1. A new substance is formed
2. Usually the change is easily reversible	2. Usually the change is irreversible
3. Usually no energy is given out or absorbed	3. Usually energy is given out or absorbed
4. The mass of the substance does not alter.	4. The mass of the substance does alter.

24. What is the difference between a compound and a mixture?

A – A compound can be defined as a substance made up of two or more elements combined together by chemical means whereas in a mixture particles of different substances are brought into close contact with each other, but they are not combined with each other chemically.

25. State, with reasons, whether each of the following is a physical or chemical change:

- A – Painting of a wall – Physical – no new substance formed
- B – Freezing of water – Physical – no new substance formed
- C – Burning of charcoal – chemical – new substance formed
- D – Adding of common salt in water – physical
- E – Sublimation of iodine – physical
- F – Rusting of iron – chemical
- G – Burning of a paper – chemical
- H – Electrolysis of water – chemical

26. State the changes that occur when ice is heated as shown below.

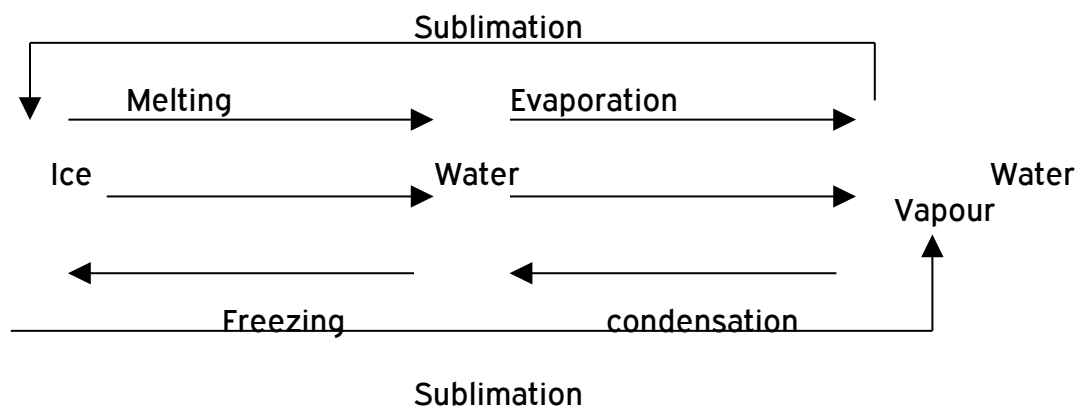

27. What does Kinetic theory of matter state?

A – States that matter is particulate and the particles are in constant motion.

28. Describe an experiment to show matter is particulate.

EXP. 1

A – Put and stir one tablespoonful of sugar in water. Taste the water now. The sugar soon disappears and you cannot see it but the water tastes sweet.

Explanation

Sugar grams separated into single tiny particles too small to be seen. They moved all through water, making it sweet.

EXP. 2

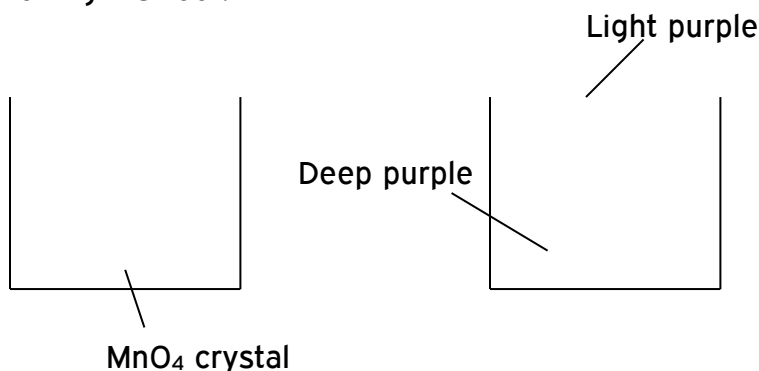

Put a crystal of Potassium Permanganate in water as shown above, Leave the beaker undisturbed for about an hour.

Observation

You will see that the water has turned purple. It is deep purple near the bottom and comparatively slightly purple near the surface.

What has happened?

Small particles of potassium permanganate got permanganate got separated. These particles have spread all over by the bumps of the moving water particles

EXP. 3

BROWNIAN MOVEMENT

– Smoke particles, strongly illuminated are viewed through microscope.

The particles are found to be in random, zigzag motion (called Brownian movement) due to the bombardment of the same by the air particles.

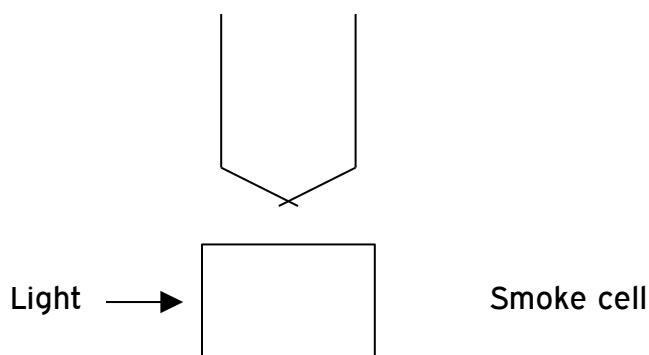

29. Explain sublimation using Kinetic theory of matter.

A – A solid can change directly to a gas, missing out the liquid state, i.e. particles break off the solid with enough energy to exist as gas particles, A gas particle can also slow down enough to become a solid without going through the liquid state.

30. The following are some of the methods used to collect gases. With reasons state which method is suitable for each of the following gases, Ammonia, carbondioxide chloride, oxygen.

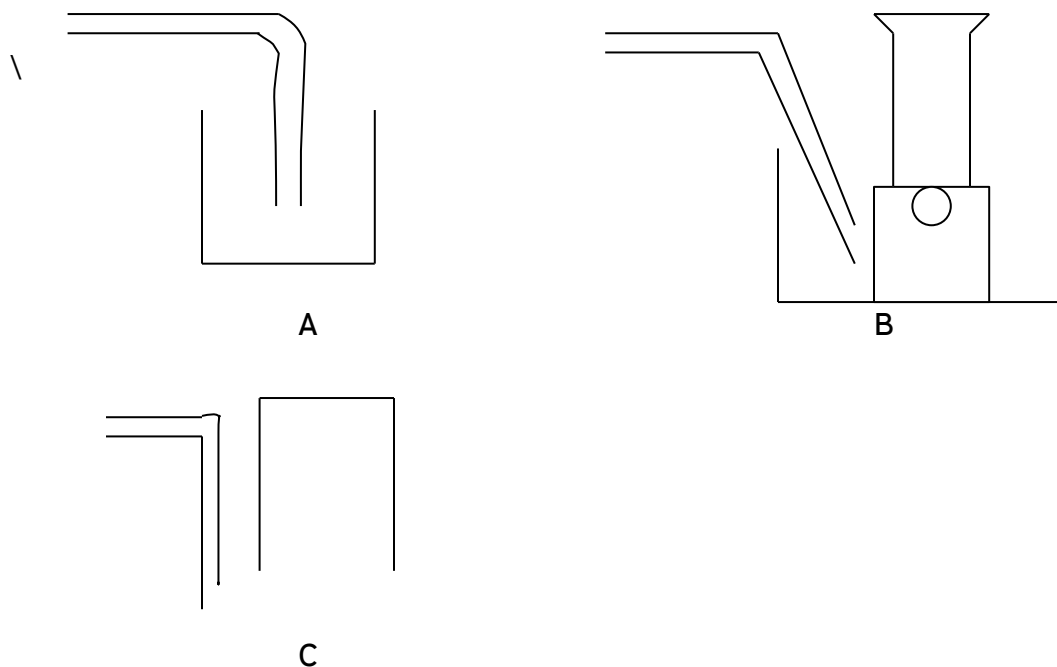

A

(i) Ammonia – method C

Reason – ammonia is less dense than air and therefore collected by upward delivery.

(ii) Carbon dioxide – method A

Reason – CO₂ is dense than air and therefore collected by downward delivery.

(iii) Oxygen – method B – It is slightly soluble in water so it can be collected over water method conveniently.

31. How do you identify pure substances in chemistry.

A – Pure substances have definite sharp melting and boiling points and therefore their purity can be determined by measuring these temperatures.

32. Describe two Industrial applications of fractional distillation.

A

(i) Refining of crude oil (Petroleum)

- In Kenya, the crude oil that comes in tankers from the middle East to Mombasa is refined at changamwe.

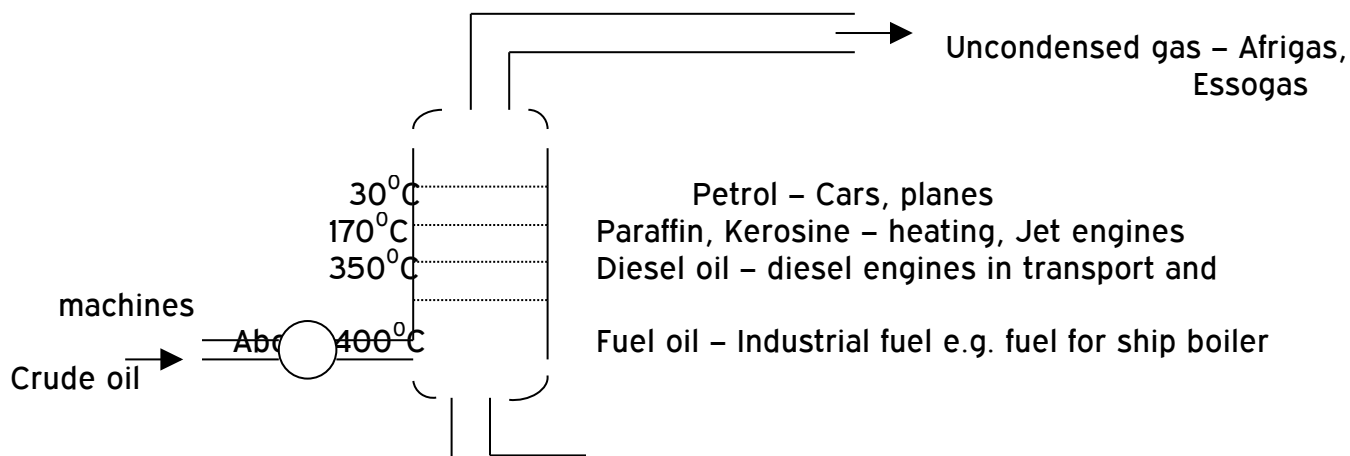

Heater
to vaporize the oil

Bitumen (Asphalt) – road making, water
proofing

- The crude oil is completely vaporised by a furnace and the vapour passes into a fractionating column a tower made up of a number of compartments which get cooler going up the column. As the vapour rises up the column, different substances condense in different compartments and the liquids formed are drawn off. The lower the boiling point of a substance, the further it will travel up the column before condensing.

(iii) Fractional distillation of Air.

A – When a gas is compressed and then suddenly allowed to expand, the expansion results in cooling. By this method, air can be cooled sufficiently to liquefy it.

- Air is freed from carbon dioxide, water vapour, dust particles etc and then compressed at 200 atmospheres pressure. It is then successively cooled until liquid air is obtained (at -200°C . or 73K). Liquid air is a transparent, pale blue liquid.
- When this liquid air is fractionally distilled, nitrogen having lower boiling point (-195°C or 78K) begins to evaporate first. Oxygen having higher boiling point (-183°C – or 90K) comes off later. This way about 99.5% pure oxygen is obtained.

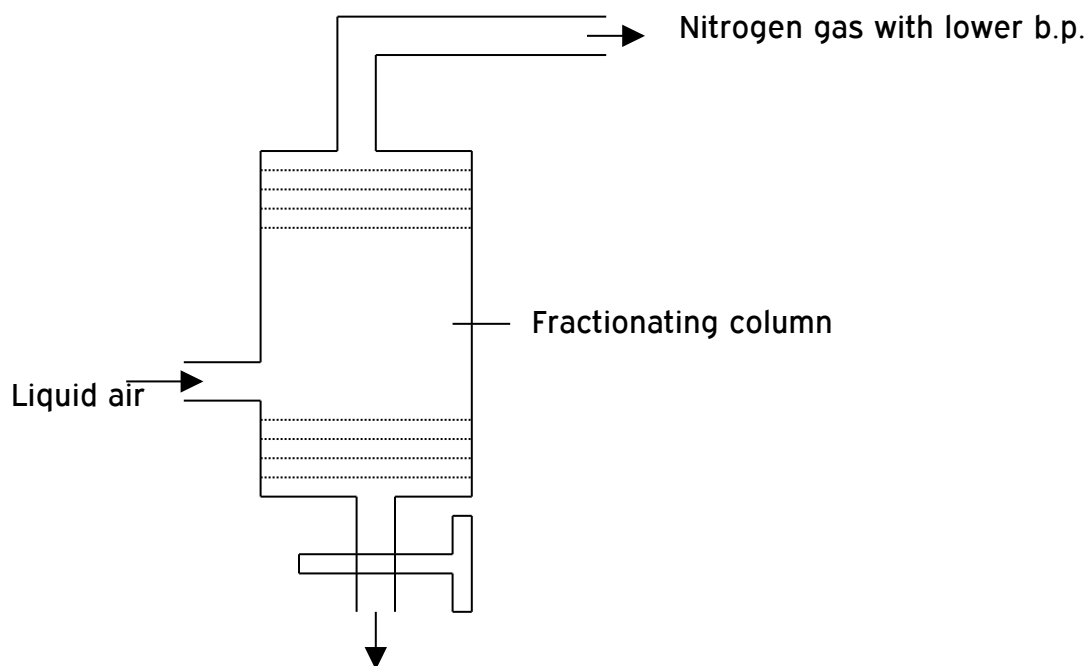

Oxygen – gas with higher b.p.

33. Below are three diagrams representing the three stages of matter. Label them appropriately.

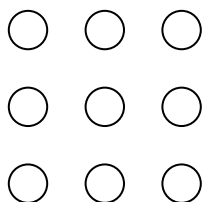

Liquid

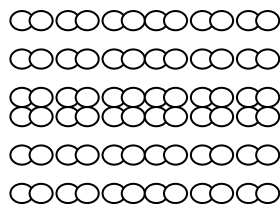

Solid

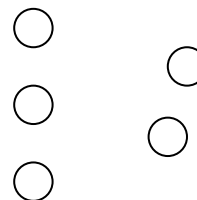

Gas

34. Why is that gases don't have definite shape?

- Particles in gases are far apart and free to move randomly in all directions.

35. Using Kinetic theory of matter explain condensation process.

- When a gas is cooled, the particles lose energy and hence slow down gradually. As they slow down they easily attract their neighbouring particles and cluster together to form a liquid.

36. Briefly explain how ice-cream vendors use solid carbon dioxide (dry ice) to keep the ice-cream frozen.

- Solid carbon dioxide absorbs heat energy from the ice – cream and changes to gas. This keeps the ice – cream cold.

37. What principle do refrigerators work on.

- Absorption of heat energy from the surroundings by a liquid or dry ice in the refrigerators. Whatever is in the cabinet cools down gradually as this loss of heat continues.

38. Why is it necessary to adhere strictly to the laboratory safety rules?

- This will enable the students carry out most of the experiments safely.

39. Name the process used to separate two solids both soluble in the same solvent; when the solids are both present in the mixture.

Fractional crystallizations.

40. Below is an arrangement which was used to prepare gas.

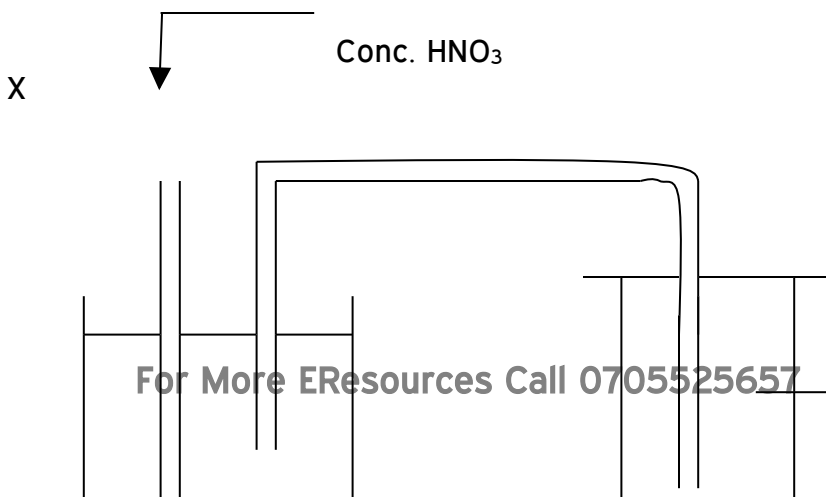

Gas X

Copper turnings

(i) Which one property of gas X can you tell from the method of preparation?

Denser than air

(ii) Identify gas X

Nitrogen dioxide

(iii) Why is Lead (II) nitrate more suitable than other nitrates for the preparation of gas X?

- Lead II nitrate crystallizes without water of crystallisation and is not hygroscopic.

41. The diagram below are of some methods used to collect gases in the laboratory.

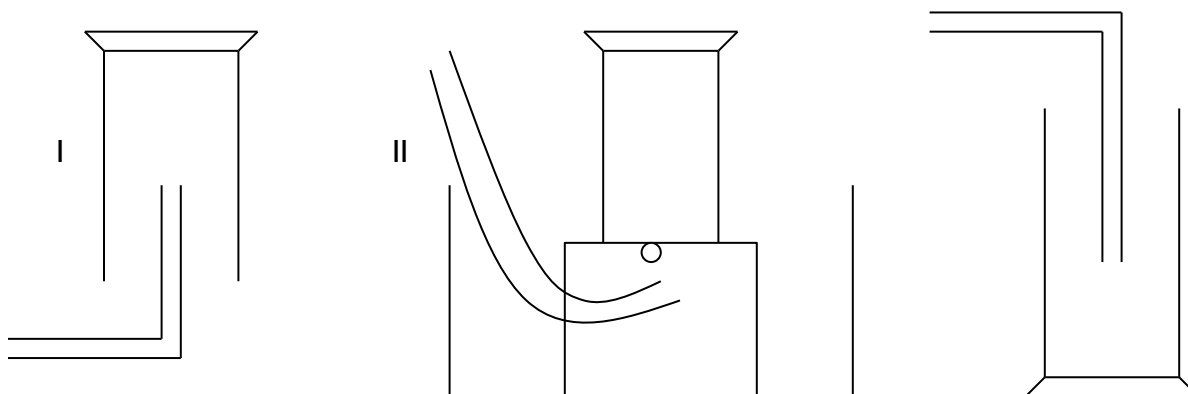

Complete the table below indicating the most suitable method for the collection of the gases given.

GAS	METHOD OF COLLECTION
HYDROGEN	I
HYDROGEN CHLORIDE	III

42. A student had the following four solids mixed and wanted separate them. The substances are given hypothetical letters to represent them;

W,X,Y and Z. The following are some of the characteristics of the solids. To obtain clean dry Y from the mixture he added water and stirred.

Substance	Solubility in water	Solubility in ethanol
W	Yes	No
X	Yes	No
Y	No	No
Z	No	Yes

- (a) (i) Explain why he did this.
This is because substance W and X would dissolve in the mixture and remain with Y and Z.
- (ii) What two steps must be carried out next to obtain clean dry Y?
He would then have to filter the mixture and remain with Y and Z. Then he would heat the two and because Z melts and the vapourises he would remain with Y or he could dissolve the two in ethanol the Z would dissolve and he would filter to get Y.
- (b) (i) To obtain pure W and X solids, water must not be added to mixture, why?
This is because they are both soluble in water and if they are mixed one wouldn't get a pure solid.
- (ii) How best would you separate the two solids W and X?
I would take the two substances W and X then heat them and because substance W sublimes on heating then would get the two separate substance W can then be cooled to change to solid again.
- (c) (i) To obtain solid Z from the mixture of W and Z it would not be wise to heat why?
This is because substance Z and W on heating form vapours and this vapour could eventually react and one can not get a pure substance.
- (ii) What should you add to the mixture of W and Z so as to help you with the separation?
You should add either water because W dissolves in water while Z doesn't so you can add then filter.
- (iii) What two steps would you carry out to obtain on pure sample of Z?
You would first mix water to the sample and W and since W dissolve Z will be filtered. After filtration you heat sample Z and then it vapourises and you collect it dry. Heating here helps in collecting the sample dry.

43. What is the difference between the melting point of a pure substance and that of an impure substance?

The melting point of an impure substance is lower than that of a pure substance and the latter is sharp while the former occur in a range.

2. ATMOSPHERE AND ITS COMBUSTION

1. What is air?

A – Air is a mixture of many gases such as N₂ – 78%, O₂ – 21%, 0.03%, and Noble gases

1%.

Water vapour, polluting gases and dust and smoke.

2. What evidence is there to show that there is water vapour in the air?

A – Take two drinking glasses. Ensure that their outside surfaces are dry. Pour equal quantity of water into both of them. Then in one of them put some pieces of ice cubes. Wait for some time and examine them.

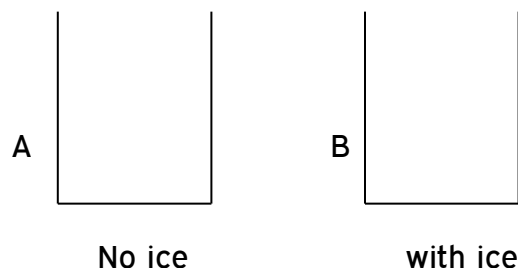

Observations

The glass with ice has colder surface and a lot of moisture condensed on its surface on its outside.

Conclusion

- This moisture on the outside of the cold glass must have come from the air. Therefore air contains water vapour which condenses on the cooler surface.
- To prove that this moisture is actually water, anhydrous copper II Sulphate on it which and after the reaction, white Copper II Sulphate turns blue.

3. Describe an experiment to show that Carbon dioxide is available in the atmosphere.

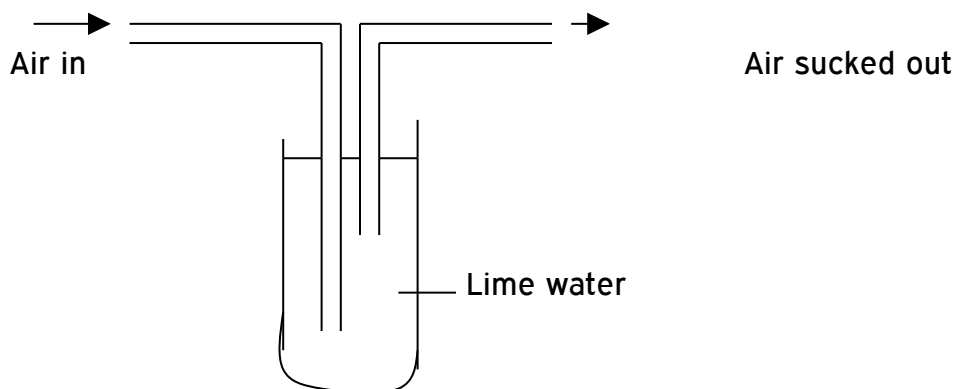

Procedure

Suck air through the apparatus as shown above for about five minutes. Make your observation as the sucking continues.

Observation

As the sucking of the air continues, lime water is found to turn milky as more air passes through it.

Conclusion

It is only Carbon dioxide that turns lime water milky or forms white precipitate of calcium carbonate.

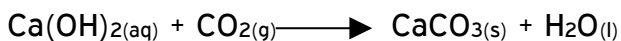

4. **Study the experiment below and answer this questions that follow.**

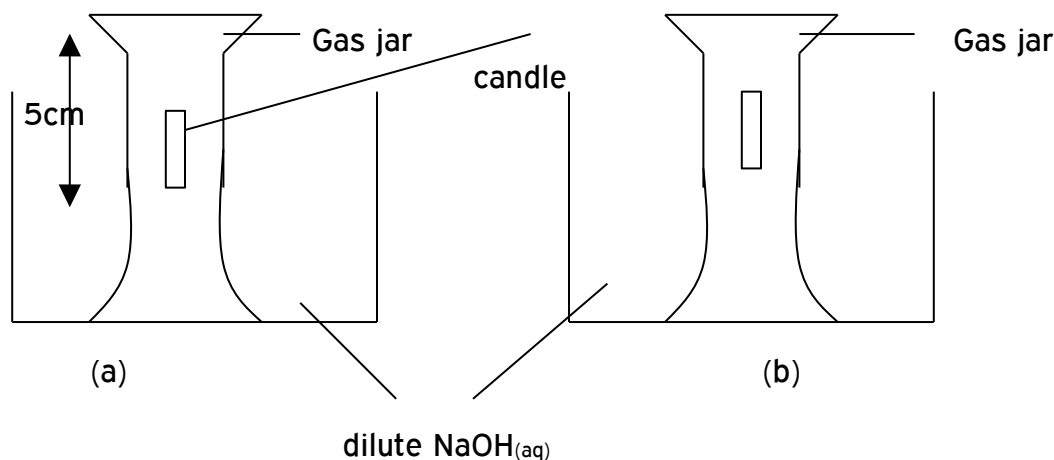

The above experiment was carried to study what happens when candle burns in a fixed amount of air. After burning of the candle the $\text{NaOH}_{(aq)}$ level in the jar rose (b) and the candle went off.

- (i) Why do you think the solution level rose inside the gas jar, filling only a part of it?
A – The solution inside the gas jar rose to take up the space which was occupied by the active part of air.
- (ii) Why did the candle go out after burning only for a while?
A – The candle went out because in a fixed amount of air only a part of it was used up called the 'active air' with the rest 'inactive air' which doesn't support combustion.

5. **Describe an experiment to determine the percentage by volume of oxygen in the air.**

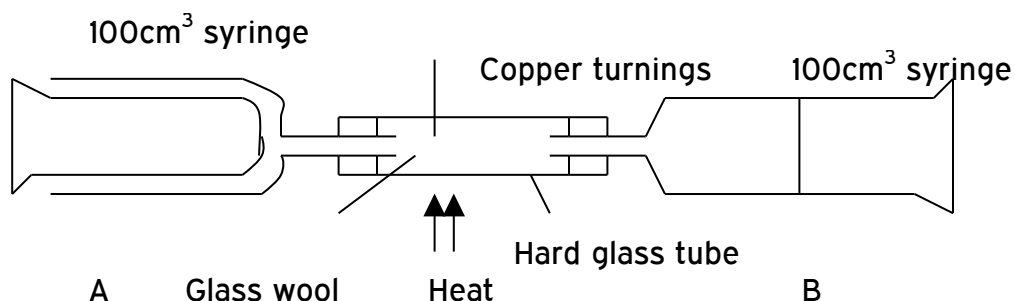

- a) The apparatus are up as shown above. The glass syringe each has a capacity of 100cm^3 .
- b) At the beginning of the experiment, take 100cm^3 of air in syringe A and no air in syringe B.
The hard glass tube is full of copper turnings.
- c) Heat the Copper turnings strongly and drive the air slowly through them from syringe A to the syringe B. Then push the air backwards from B to A. Continue passing the air

backwards forwards between the two syringes.

- d) The oxygen in the air combines with hot copper to form black copper II oxide.

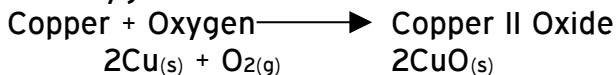

- e) After about five minutes, stop heating and allow the apparatus to cool. Push the remaining air back into syringe A and measure the volume of air left.
- f) Repeat heating, pushing air slowly to and from one syringe to the other. Cool again and measure the volume again.
- g) When there is no further change in the volume of air left, i.e. no more copper II oxide is being formed, stop heating.
- h) Let the apparatus cool and take the final measure of air. The amount of oxygen in air is equal to decrease in volume of the air.

Original amount of air in syringe A = 100cm^3

Amount of air left in syringe A = 79cm^3

Amount of air used up (oxygen) = $(100-79)\text{cm}^3 = 21\text{cm}^3$

Percentage of oxygen in air = 21%

6. Why is there any increase when a metal like magnesium is burned in air?

A – When magnesium is burned in air, it chemically combines with oxygen gas to form a compound called magnesium oxide which is heavier than the metal i.e. the white ash is heavier than the original piece of magnesium.

Thus when an element is heated or burnt in air, it combines with oxygen from air and gains in weight.

7. (i) What is rust?

A – Is hydrated Iron III Oxide ($\text{Fe}_2\text{O}_3 \cdot \text{XH}_2\text{O}$)

(ii) What are the conditions necessary for rusting?

A – Iron

- Water
- Oxygen

(iii) List some methods used to prevent rusting.

- Painting
- Electroplating
- Galvanization
- Oiling and greasing in plating
- Chromium plating
- Alloying
- Anodizing

(iv) On what basis are the methods used above designed?

A – The methods for preventing rusting are based on the fact that Iron needs to be kept out of contact with air and water.

8. Describe an experiment to investigate the "active part of air".

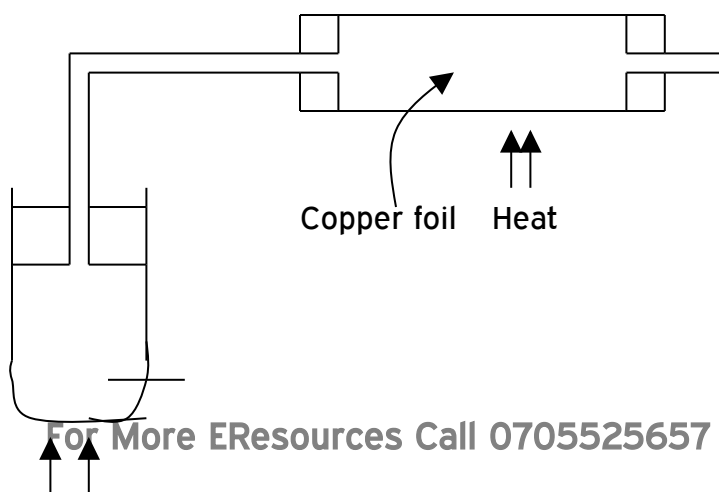

Heat

Procedure

Arrange the apparatus as shown above.

Heat Potassium Permanganate for a few seconds before heating the copper foil.

Now heat both the Permanganate and copper. Record your observations.

Observation

When copper is heated in both air and oxygen it turns black. This implies that oxygen must be present in air and is responsible for turning copper black when heated.

Oxygen is therefore the active of air and is responsible for rusting of iron as well

Potassium Permanganate was heated first in this experiment to produce oxygen which drove out all the air in the apparatus.

9. What gases are a common pollutant in the atmosphere.

A

- Sulphur dioxide
 - Nitrogen chloride
 - Carbon monoxide
- } Gases

Solids { Solid particles – produced by inefficient combustion of fuels.

Smoke, consists of carbon, tar, salts.

These particles are very small and so, they can enter the lungs and be retained there.

- This promotes respiratory problems and increase the risk of lung cancer.

10. What appropriate measures are being taken to reduce atmospheric pollution?

A

- (i) Improvement of combustion of fuel in petrol and diesel engine.
- (ii) Introduction of better processing of fuels to make them free from sulphur compounds.
- (iii) Introduction of better and more efficient filter systems in industries.
- (iv) Introduction of smokeless solid fuels or fuels like hydrogen.

11. Write down a chemical equation to show how oxygen is prepared in the lab.

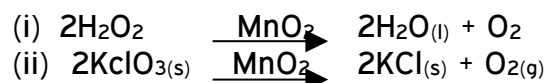

12. List the properties of oxygen gas.

Physical

- Colourless & odourless & tasteless
- It is slightly denser than air

- It is slightly soluble in water
- BP – 183°C

Chemical properties

- Neutral to litmus
- Relights a glowing splint but doesn't burn (test for oxygen) i.e. It isn't combustible
- It forms oxides with metals and non-metals.

13. What is the role of manganese (IV) oxide in the preparation of oxygen gas?

- It simply speeds up the rate of decomposition of hydrogen peroxide to yield oxygen. Hence it is a catalyst.

14. FILL THE TABLE BELOW STATING WHAT HAPPENS IN EACH COLUMN WHEN ELEMENTS ARE BURNT IN OXYGEN.

Element	How it burns oxygen	Product	Colour of product in Litmus solution
Sodium	Bright Golden yellow flame	Na ₂ O ₂	Blue
Sulphur	Bright blue flame	SO ₂	Red
Phosphorus	White flame	P ₂ O ₅	Red
Carbon	Red glow	CO ₂	Red
Iron	Yellow sparks	FeO	-
Magnesium	Bright white flame	MgO	Blue
Copper	Blue flame	CuO	-
Calcium	Bright red flame	CaO	Blue

15. Distinguish between acidic and basic oxides.

- Acidic oxides are oxides of non-metals which dissolve in water to form acidic solutions while basic oxides are those of metals of which some dissolve in water to form alkaline solution which turn red litmus paper blue. It is important to note that not all basic oxides dissolve in water.

16. An experiment on competition for oxygen was carried out and results were tabulated in the table below. Use information in the table to answer the questions that follow.

Oxide \ Element	MgO	CO ₂	CuO	PbO	ZnO	Fe ₂ O ₃
Magnesium	No reaction	MgO + C	MgO + Cu	MgO + Pb	MgO + Zinc	MgO + Fe
Carbon	No reaction	CO	CO ₂ + Cu	CO ₂ + Pb	CO ₂ + Zn	CO ₂ + Fe
Lead	No reaction	No reaction	PbO + Cu	No reaction	No reaction	No reaction
Zinc	No reaction	No reaction	ZnO + Cu	ZnO + Pb	No reaction	ZnO + Fe
Iron	No reaction	No reaction	Fe ₂ O ₃ + Cu	Fe ₂ O ₃ + Pb	No reaction	No reaction

- (i) What is the best conclusion that can be drawn on the basis of the above results?
- More active elements take oxygen from the less active ones.

(ii) What is the order of reactivity of elements in this experiment?

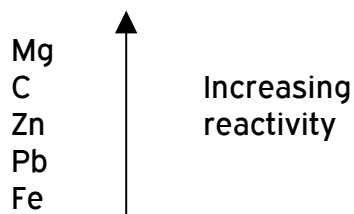

(iii) What are the products formed where a reaction occurred?

- An oxide of the more reactive element and the element of the less reactive of the two.

(iv) If you were given an oxide copper how would you obtain copper metal from it?

- I would simply heat the copper oxide with an element carbon to obtain the brown copper metal after reduction.

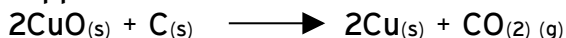

17. List six commercial uses of oxygen.

- In the oxy-acetylene flame
- In the oxy-hydrogen flame
- As an aid to breathing
- In still production
- Fuel – liquid oxygen is used to burn the fuel in some space rockets.
- Explosives – liquid oxygen mixed with charcoal and petrol is used as explosive in mines.

18. Give the name of a metallic oxide (different in each case) which?

(i) On heating yields oxygen and a lower oxide of the same metal.



(ii) Is yellow when hot and white when cold.



(iii) Is easily converted to a metal on heating.



(iv) Does not dissolve in water but a base.



(v) Dissolve in water to form an alkali – Na_2O_2 , CaO

19. Pollution is a health hazard which is directly proportional to the level of industrialisation in developing countries. Give evidence to justify this proclamation.

The following are sources of pollutants.

- (a) Exhaust gases and dust from industries such as; paper, sugar and cement industries.
- (b) Exhaust emissions from motor vehicles.
- (c) Some activities in the "Jua kali" industry such as burning tyres to get wires and threads.
- (d) Nuclear reactors have become an important source of energy. But radiation from nuclear stations can pose a great danger to the environment as was seen during the Chernobyl nuclear reaction disaster of 1986 in USSR.
- (e) Aerosols such as insecticides and perfume sprays containing chlorofluorocarbons (cfc) used as propellants. The CFC's are gradually accumulating in the atmosphere and it has been proven that they react with the ozone layer depleting it. This means that man likely to be exposed to harmful radiations from the sun.

20. What is water of crystallization.

- This is the definite amount of water held within the crystal structure of $\text{CuSO}_4 \cdot 5\text{H}_2\text{O}$, $\text{Na}_2\text{CO}_3 \cdot 10\text{H}_2\text{O}$.

21. Where is the competition for oxygen reaction applied industrially?

- This type of reaction is applied in the extraction of some metal e.g. Lead, Iron, Zinc and Copper are below carbon in the activity series or are less reactive than carbon. These metal therefore are obtained by reducing their heated oxides with carbon (coke) or carbon monoxide.

22. Carbon dioxide doesn't support combustion, yet burning of magnesium ribbon introduced in jar of carbon dioxide continues to burn. Explain this, giving the chemical equation involved.

- When a burning magnesium is introduced into a gas jar containing carbon dioxide, the intense heat burning magnesium produces, decomposes the carbon dioxide gas into carbon and oxygen. This oxygen now supports the continuous burning of magnesium.

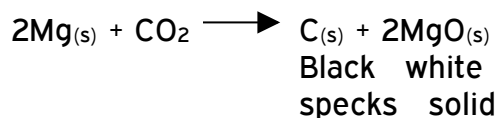

WATER + HYDROGEN

1. List four sources of water.

- Rainfall
- Rivers
- Seas
- Boreholes
- Wells

2. Describe an experiment to show that water is an oxide of hydrogen.

- Water is formed when hydrogen combines with oxygen. Hydrogen can be generated by the reaction between dilute hydrochloric acid on Zinc metal.

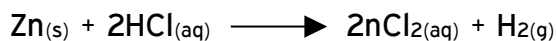

- The gas is dried by passing it through anhydrous calcium chloride.

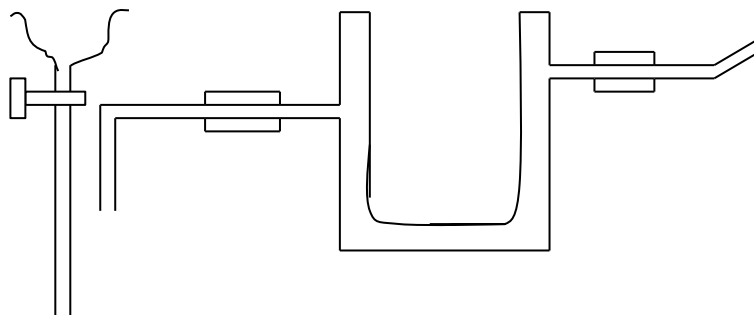

- So hydrogen is burned in air and the vapour formed condensed. The liquid formed changes the blue Cobalt II chloride paper to pink indicating that the liquid is water.

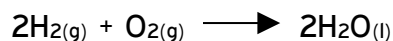

3. A form one pupil lit a bunsen burner with its air hole fully open. The regions of the flames were labelled as shown below.

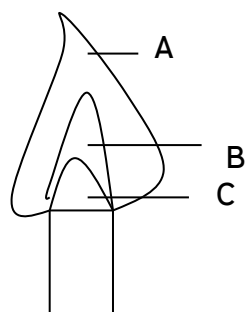

- (a) Name part (A) Light blue / Pale blue
 (b) Which region is the hottest A
 (c) Which colour is region C? Colourless

4. Paper chromatography of a plant extract gave the following results.

SOLVENT	NO. OF SPOTS
X	4
Y	1
W	2

Which Solvent is the most suitable for purifying the extract? Explain.

Solvent X – because most of the dyes in the extract dissolve in it. Hence more spots are seen on the paper.

5. The apparatus below was used in an experiment to burn hydrogen in air.

5(i)(a) Name substance X and M.

X – Anhydrous calcium chloride

M – Water

(ii) What is the use of substance X in this experiment.

- It is for drying purposes.

(iii) (b)

Explain why it is necessary to pass hydrogen through the Q1 apparatus for some time before lighting it up?

- To expel any oxygen trapped within the apparatus which would otherwise cause hydrogen gas burn explosively damaging the apparatus.

6.

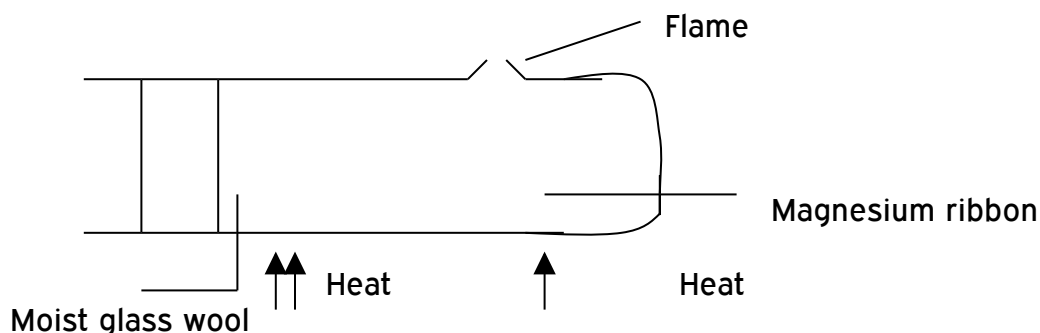

- What gas is burning at A?
Hydrogen

7. (a) Name a gas that will reduce copper II Oxide.

Hydrogen

(b) Describe what you would see when the reaction occurs.

- The black copper II Oxide is reduced to a brown copper metal and drops of a colourless liquid are seen to condense on the colder areas of the combustion tube.

(c) Write an equation for the reaction.

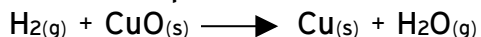

(d) Will this reagent reduce magnesium oxide?

Explain your answer

Hydrogen won't reduce magnesium oxide because magnesium metal is higher in the reactivity series than hydrogen therefore this reaction will not be feasible.

8. In an experiment, dry hydrogen chloride gas was passed through heated Zinc turnings as shown in the diagram below. The gas produced was then passed through heated Lead II Oxide.

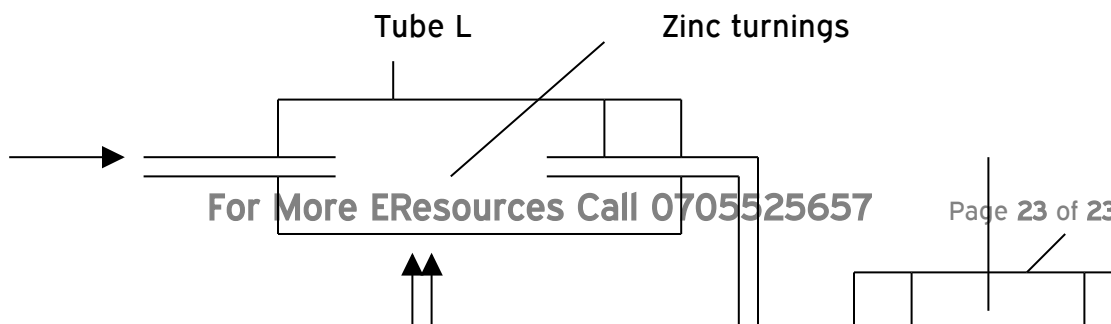

Dry HCl (g)

PbO

|

Tube V

Heat

Gas

Heat

Flask
Z

Water

- (i) What is the function of the water in the flask?
 - To dissolve the unreacted Hydrogen chloride gas.
- (ii) Write equations for the reactions that took place in the tubes.

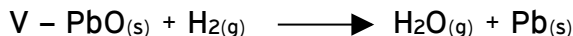
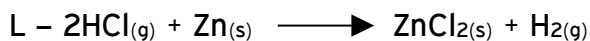

- (iii) How would the total mass of tube V and its contents compare before and after the experiment? Explain.
- After the experiment the total mass of tube V would be less than its initial mass owing to the reduction of PbO by hydrogen gas which takes away the oxygen thus lowering the total mass.

9. An experiment was set up as shown in the diagram below.

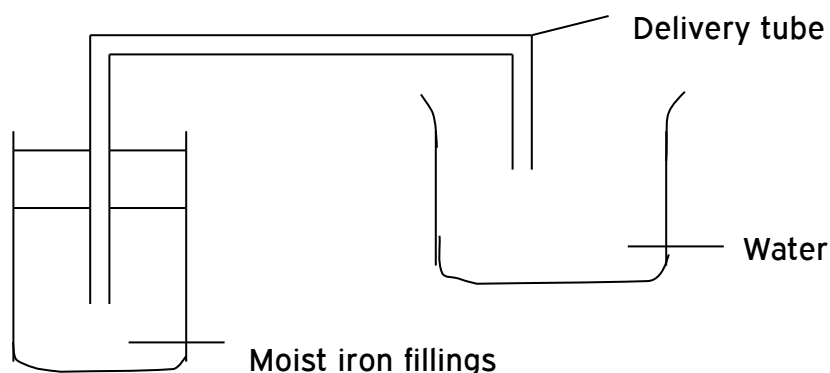

Explain what is observed after a few days.

- Iron will rust and water level in the delivery tube will rise to occupy the space left behind by the oxygen (active part of air) that was used by the rusting iron.

10. The diagram below represents a paper chromatogram of two sugars A and B.

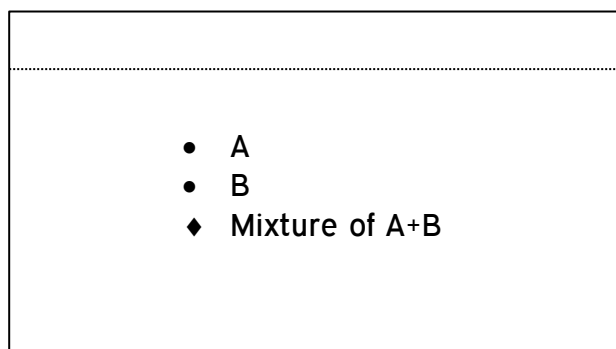

State one property of A that makes it move faster than B towards the solvent front.

- A is very soluble in the solvent used and doesn't stick to the paper like B.

11. The diagram below shows apparatus set up to study the effect of burning a candle in air.

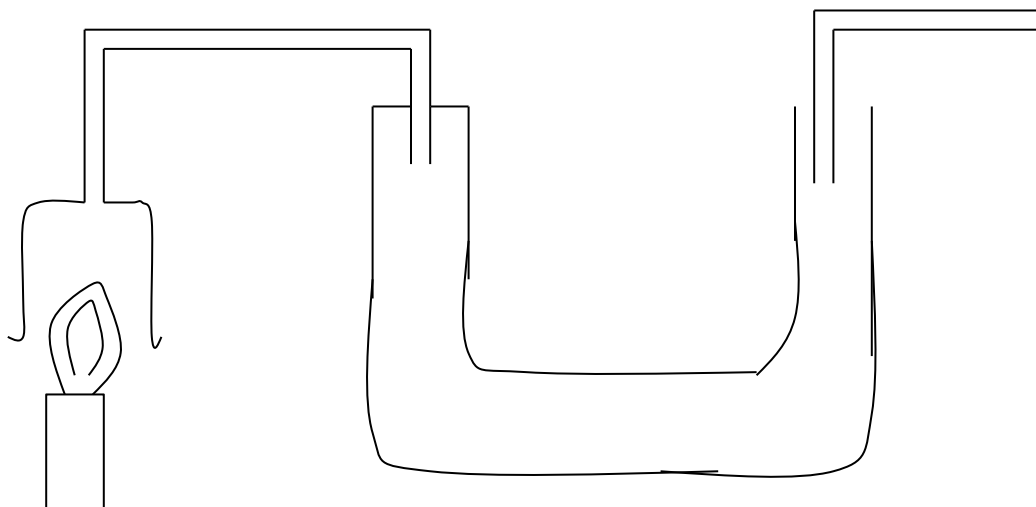

- (i) Explain why the candle will not continue to burn unless the suction pump is turned on.
- Suction pump causes a continuous flow of air into the apparatus from outside thus providing oxygen from the air which supports burning of the candle. Without the suction pump the candle will burn for a while and go off for lack of oxygen.
- (ii) The weight of the u-tube B increases considerably while the candle is burning. Give a reason for this.
- Concentrated Sulphuric acid is hygroscopic and therefore absorbed water formed from the burned candle thus making the weight of the u-tube increase.
- (iii) Is the burning of the candle the only reason for the increase in weight of B? Explain your answer.

- No. The incoming air contains some water vapour which is also absorbed by the acid besides there is some carbon which will contribute to the weight increase.
 - (iv) From the above, which element can you conclude is contained in the candle?
 - Hydrogen.
 - (v) Which substance is absorbed by the Lime water in C?
 - CO₂ gas
 - (vi) What observation would you make the Lime water in C?
 - White precipitate of calcium carbonate is formed
- $$\text{Ca(OH)}_{2(\text{aq})} + \text{CO}_{2(\text{g})} \rightarrow \text{CaCO}_{3(\text{s})}$$
- (vii) Which other element is therefore contained in the candle?

12.

The above experiment was carried out to investigate the reaction between steam and magnesium. Answer the question that follow.

- (i) Why is the wet sand heated?
 - To produce steam which will react with the magnesium ribbon.
- (ii) What was observed when steam was passed over hot magnesium ribbon?
 - Magnesium burned brightly in steam to form white magnesium oxide powder
- (iii) Name gas y – Hydrogen.
- (iv) How would you confirm its identity?
 - It would burn with a 'pop' sound if a burning splint is brought near the mouth of the tube. This confirms beyond any doubts that the gas is hydrogen.

13. Below are the main sources of water pollution. Explain how each of them affects the environment?

- (i) Sewage
- (ii) Fertilisers
- (iii) Chemicals/Pesticides
- (iv) Oil and detergents

(i) **Sewage**

- Dissolve oxygen in water is used by bacteria and thus most of the living organisms in water die and this water becomes cloudy and smelly.

(ii) **Fertilizers**

- Rain washes fertilizers into rivers and lakes and thus bacteria grow faster and again use up all oxygen dissolve in water.

(iii) **Chemicals / Pesticides**

- Acids, alkalis, dyes and spraying chemicals are poisonous to animals and plants.

- (iv) Oil forms layers on water and detergents form foam in water and thus no more oxygen dissolved in water from atmosphere.

14. The flow chart below shows the treatment of water in water supply systems.

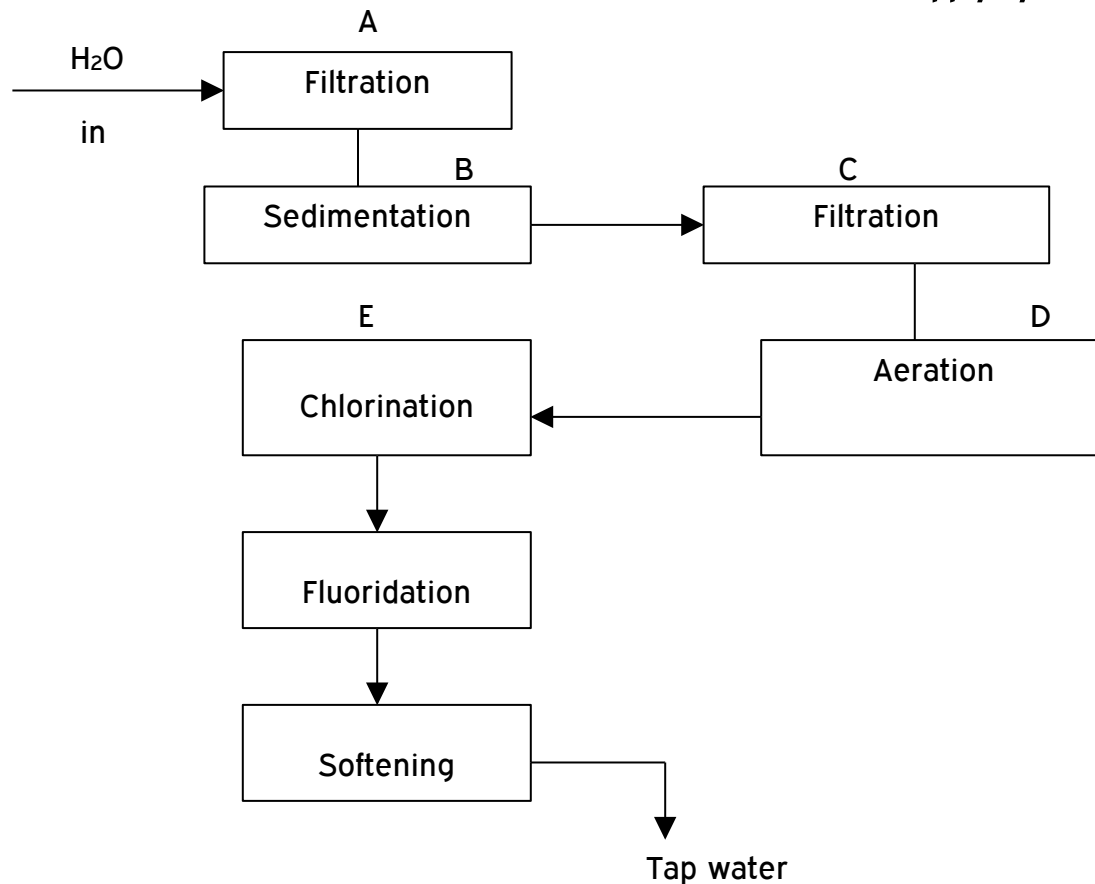

(i) Suggest a suitable substances that can be used in filtration chambers A and C.

- Stones
- Gravel
- Coarse and fine sand

(ii) Aluminium sulphate (Alum) is used in the sedimentation chamber B. Explain the action of aluminium sulphate.

- It is a coagulant which makes the suspended particles clamp together and settle on the bottom of the storage tanks.

(iii) Why is aeration important here.

- This helps in the killing of some bacteria by oxidation and effects of sunlight.

(iv) Why is chlorination necessary?

- Chlorine is used here as a germicide to make water quite safe to drink.
- (v) Explain the importance of fluoridation.
- There is medical evidence that the presence of about one part per million (P.P.M) of sodium fluoride in drinking water reduces the decay of children's teeth. That is why some water works use Sodium fluoride.
- (vi) Water pollution which can be a health hazard may be divided into three categories depending on their cause. List them down and briefly the causes and their remedies.

State.

- (i) **Physical pollution of water** – This mainly refers to suspended matter and turbidity – from soil erosion and colloidal waste.
 - This can be corrected by addition of coagulants such as Alum.
- (ii) **Biological pollution** – This is due to the presence of bacteria, protozoa, viruses and parasites. Infections like cholera, typhoid and dysentery have been traced to contaminated water supplies.
 - Addition of chlorine kills them and makes the water safe to drink.
- (iii) **Chemical pollution** – This is from industries and agriculture (acids, alkali + heavy metal cations, soap production, food processing fertilisers etc).
 - The heavy metals are precipitate by adding calcium hydroxide.
 - Fertilisers, the use is strictly controlled.
 - Most detergents now marketed are biodegradable and can be washed into lakes and rivers without any harmful effect.
- (iv) **Thermal pollution** – This arises from the use of water by manufacturing and power plants.
 - This results to the decrease of dissolved oxygen and oxygen is required by all plant and animals life.
 - Factories like Pan African Mill, Webuye have a good sophisticated treatment plant which involves cooling of water so that as it results to the river is in acceptable standard.

15. Define and give one example of each of the following; water of crystallization, efflorescence, hygroscopic, deliquescence.

What happens when blue copper II Sulphate crystals are left in a desiccator?

- **Water of crystallization** – is the definite amount of water contained in a crystal e.g. $\text{COCl}_2 \cdot 6\text{H}_2\text{O}$, $\text{Na}_2\text{CO}_3 \cdot 10\text{H}_2\text{O}$ etc.
- **Efflorescence** – is the process of losing water of crystallisation into the atmosphere when exposed to the air, $\text{Na}_2\text{SO}_4 \cdot 10\text{H}_2\text{O}$, $\text{Na}_2\text{CO}_3 \cdot 10\text{H}_2\text{O}$ \rightarrow $\text{Na}_2\text{CO}_3 \cdot \text{H}_2\text{O} + 9\text{H}_2\text{O}$
 $\text{CuSO}_4 \cdot 5\text{H}_2\text{O}$ etc.
- **Hydroscopic substance** – This one would absorb water from the atmosphere but doesn't dissolve in it to form a solution. E.g. concentrated Sulphuric acid, ethanol, CaO, CuO, etc.
- **Deliquescence** – is the process by which some salts absorb water from the atmosphere and dissolve in the water to form a solution e.g. NaNO_3 , CaCl_2 , FeCl_3 , NaOH etc.
- When blue Copper II sulphate crystal are left in a desiccator, they lose water of crystallization and change from blue to white.



16.

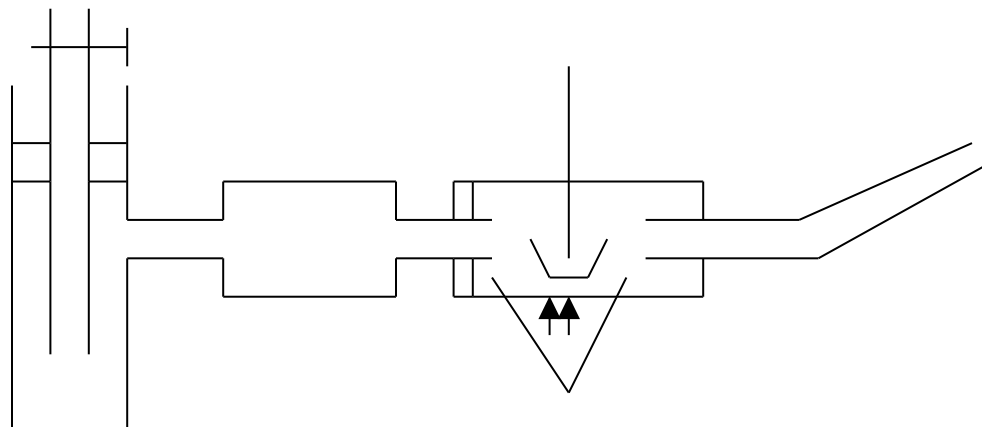

The powder D is copper oxide in a porcelain boat; which is heated in combustion

(a) What is the chemical A?

Zinc granules.

(b) What is the chemical B?

Dilute Hydrochloric acid.

(c) From which of the two A and B, is the gas hydrogen liberated.

B

(d) Write an equation for the reaction between A and B.

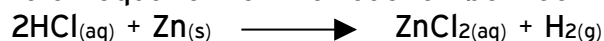

(e) What is the colour of the powder D?

(i) At the beginning of the experiment?

B

(ii) At the end of the experiment?

Brown

(f) What happens to the anhydrous copper sulphate during the experiment? What does it show?

- It turns from white to blue.

- This shows that some water molecules have been formed after CuO was reduced by the hydrogen.

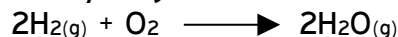

(g) What is the substance in the tube C and what is the function?

C- Anhydrous Calcium Chloride

- It is a drying agent.

(h) What is the name of the reaction between copper oxide and hydrogen? Write the equation for this reaction.

- Redox reaction



Reduction

(i) Name one solid substance which has a similar function to that of hydrogen in this experiment.

- Carbon

(j) In the experiment the following figures were obtained.

Mass of porcelain boat = 7.8g

Mass of boat + copper oxide = 9.8g

Mass of boat + the substance remaining

When cool = 9.0g

(i) What is the mass of copper oxide?

Mass of copper oxide = $9.8 - 7.8$

= 2.0g

(ii) What is the substance left when cool?

Copper metal

(iii) What is the mass of oxygen present in this mass of copper oxide?

$9.8 - 9.0 = 0.8\text{g}$

(iv) What is the percentage by mass of oxygen in this sample of copper oxide.

Mass of copper oxide = 2.0g

Mass of oxygen = 0.8g

Percentage by mass of oxygen =

$\frac{0.8}{2.0} \times 100 = \underline{40\%}$

2.0

17. (i) How is hydrogen manufactured on a large scale? Give three industrial uses of the gas.

(i) It is produced as by-product in the cracking of oils.

(ii) In the electrolysis of brine.

(iii) In the action of steam on hydrocarbons such as methane in the presence of nickel catalyst at 800°C to yield water gas. When this gas is treated with more steam, CO_2 and more hydrogen is formed. Then CO_2 is removed by dissolving it in water in pressure.

Three Industrial uses of hydrogen

(i) Synthesis of Ammonia, hydrogen chloride and methanol.

(ii) In the manufacture of margarine and cooking fats – hydrogenation process.

(iii) In the oxy-hydrogen blow pipe and atomic hydrogen torch, used to produce high temperatures for welding etc.

(ii) Oxygen and nitrogen are obtained from air by fractional distillation. Why can this method be used for this purpose yet cannot be used to obtain hydrogen and oxygen from water?

Air is a mixture which can be separated by physical means – fractional distillation, water is a compound of oxygen and hydrogen and these two can't be separated by distillation but by a chemical means like electrolysis.

18. (a) Explain what is meant by "hard water".

- Hard water does not form lather easily with soap as it contains dissolved solids (salts of calcium and magnesium).

(b) Give the names and formulae of compounds which cause temporary hardness and those which cause permanent hardness.

- Temporary hardness (T.H) can be caused by calcium hydrogen carbonate, $\text{Ca}(\text{HCO}_3)_2$

and magnesium hydrogen

Carbonate, $\text{Mg}(\text{HCO}_3)_2$

- Permanent hardness (P.H) can be caused by the presence of calcium sulphate (CaSO_4) and Magnesium Sulphate (MgSO_4), Calcium Chloride (CaCl_2) and Magnesium Chloride (MgCl_2)

(c) Explain, giving ionic equations, how boiling removes temporary hardness only which the addition of washing soda removes both types of hardness.

T.H is that which can be removed by simply boiling. When T.H water is boiled, a deposit of insoluble carbonate is formed.

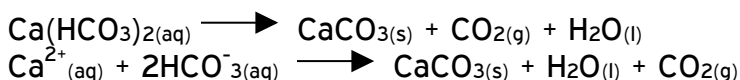

P.H. is that which can't be removed by boiling as Sulphates/Chlorides of calcium and magnesium do not decompose on heating. It can be removed by addition of Sodium Carbonate (Washing soda) when insoluble Carbonate is precipitated.



(d)(i) You are given a clear liquid in a beaker. Explain how you would confirm that the liquid is pure water.

- A few drops of the liquid are added to white Copper II Sulphate. Which turns blue, showing the presence of water.
- The determination of its b.p (100°C at sea level) shows that it is pure water. When evaporated to dryness, no residue is left. This also shows that the liquid is pure water.

(ii) If the liquid in (i) above is soft water, how would you convert it into water possessing temporary hardness.

- Add Calcium Carbonate powder to the sample of water and bubble carbon dioxide gas through it.

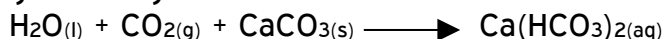

- The formation of $\text{Ca}(\text{HCO}_3)_2(\text{aq})$ means the presence of temporary hardness.

(iii) In what way is hard water a nuisance when used in certain industries as a source of steam power? State one advantage of hard water.

- Scale (deposit of CaCO_3) is formed in steam boilers ('fur' in kettles). Heat does not pass through the scale easily; there is wastage of energy.

Advantage

- Ca^{2+} ions are needed by the body for bones and teeth formation
- Shells of animals and eggs of many contain Calcium Carbonate, and some comes from hard water.

(iv) Explain why the ability of temporary hard water to conduct electricity falls when the water is boiled but it is not much affected when the T.H is removed by addition of washing soda.

- As the water is boiled, T.H is being removed i.e. Ca^{2+} and HCO_3^{-} ions are being removed. As the quantity of ions in solution decreases, the conductivity of electricity falls. At the end, there will be calcium carbonate, water and carbon dioxide which

don't conduct electricity.

- When washing soda (Sodium Carbonate) is added, Calcium Carbonate is precipitated but the solution contains Sodium hydrogen Carbonate i.e. there are Na^+ and HCO_3^- ions in solution which conduct electricity.

(v) **Name a method by which hard water can be softened easily and conveniently at home. State briefly how it works.**

- Ion exchange – Hard water is run through a resin in which the Ca^{2+} and Mg^{2+} ions are exchanged for Na^+ ions which do not react with soap.

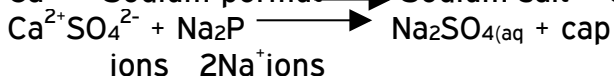
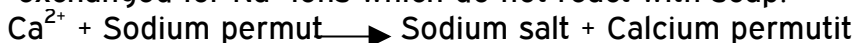

- When all the Na^+ ions in the permutit have been replaced by Ca^{2+} and Mg^{2+} ions, the resin is regenerated by passing a solution of fairly concentrated common salt (brine) down it. So another ion exchange takes place as shown below.

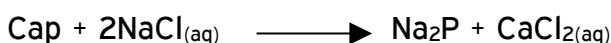

19. (i) **Name the materials used to prepare soaps and soapless detergents.**

- Animal fats or vegetable oils
- Caustic soda (NaOH)

(ii) **Why are soaps now outnumbered by synthetic (soapless) detergents?**

- Soapless or synthetic detergents are made from petroleum by-products e.g. ethene and benzene and consist of molecules which are similar in form and action to those of soap after being reacted with Conc. H_2SO_4 and NaOH. Both have molecules with a long covalent 'tail' and an ionic 'head' e.g.

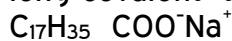

Chain head.

- Hard water consumes soap before, lather is formed. This is because Calcium/Magnesium stearate salts are insoluble and form scum, unlike soap, calcium and magnesium salts of synthetic detergent are soluble in water and thus do not form scum. Moreover, soaps are made from greatly needed raw foods. Many varieties synthetic detergents are possible, some of them for specific purposes.

20. **Explain briefly the following observations about a sample of hard water (a) when boiled it formed some white precipitate (b) even after boiling the water formed scum with soap (c) Sodium Carbonate made the water completely soft.**

- This water had both temporary and permanent hardness. Boiling removed only T.H and that's why these was still scum formed. Sodium Carbonate removed the P.H. which is never affected by boiling.

ACIDS, BASES AND SALTS

1. **What are acids?**

These are solutions formed by dissolving some non-metallic oxides in water whose PH is below 7 and the same turns blue litmus paper red.

2. What are bases?

These are soluble metal oxides which form alkaline solution with water, the same turns red litmus paper blue.

3. What are salts?

These are the substances formed when hydrogen ions of acids are partially or wholly replaced by metal ions or an ammonium radical. They also have metallic and non-metallic parts.

4. What are indicators?

These are substances which have one colour in acidic solutions and another colour in alkaline solutions.

5. (i) Lemons, vinegar, rhubarb and acid drops all contain acids. How would you describe their taste?

- They are sour.

(ii) What are bicarbonate of soda and milk of magnesium usually used for?

- These two are used to neutralise acid in the stomach.

(iii) Why is it better to use indicators rather than the sense of taste when testing for acids and alkalis.

- Acids corrode and bases are caustic and may burn your tongue hence it is advisable to use indicators which are convenient because no risk taking is involved and will simply show one colour in acidic solution and another colour in an alkaline solution.

6. (i) Define an acid.

- This is defined as a compound containing hydrogen, all or part of which may be replaced by a metal (or a metallic radical) to give a salt.

(ii) Define a base.

- This is a substance which reacts with an acid to form a salt and water only.

7. State how you can determine the strength of acids and alkalis.

This can be measured by using a universal indicator along with a PH scale. The different colours of the universal indicator correspond to different PH values, usually ranging from 0 to 14.

8. (a) List four of each group and specify whether strong or weak.

(i) Acids

- HCl – Hydrochloric acid – strong
- H₂SO₄ – Sulphuric acid – strong
- H₄C₂O₂ – Acid – weak
- HNO₃ – Nitric acid – strong
- H₈C₆O₇ – Citric acid – weak

(ii) Alkaline solutions

- NH_4OH – ammonia solution – weak
- NaOH – Sodium hydroxide – strong
- $\text{Ca}(\text{OH})_2$ – Calcium hydroxide – strong
- KOH – Potassium hydroxide – strong

(b) State the uses of four alkaline solutions.

- Ammonia solution – In laundry work
- Calcium hydroxide – treating soil which is too acidic to be fertile.
- Magnesium hydroxide – indigestion tablets. (laxatives)
- Sodium hydroxide – oven cleaners to making soap.

9. (i) **What is neutralisation?**

- Is a process whereby a certain amount of acid is required to cancel out or destroy a fixed resulting solution is neutral. A salt and water are formed.

(ii) **What is the importance of acid-base neutralisation?**

- Acids of ten cause problems in life and to be on the save side, cauncelling their effects using alkaline solution is the answer.

(i) Our stomach contains HCl of PH volume 2. When there is excess acid formed in the stomach, we have painful stomachache. This is indigestion and neutralization is used as a remedy. An antacid tablet containing milk of magnesia is taken to relieve the sufferers from pain.

(ii) Acids may build up in soil causing the soil to go acidic or sour farmers may not be able to grow good crops if the soil is too acid. Hence the use of lime serves as the remedy for it rises the soil PH.

(iii) Acids can build up, especially in the teeth, and cause tooth decay. These acids are produced by bacteria feeding on food particles trapped between the teeth. Colgate, close-up etc are all basic

(iv) Protective layers on some metals are destroyed by acids, causing the underneath surface to corrode.

10. (i) **List five methods used to prepare salts in the laboratory regardless of whether the salts are soluble or insoluble.**

- Direct synthesis
- Double decomposition
- Neutralization method
- The insoluble base method with acids
- Metal – acid reaction method
- Metal carbonate – acid reaction method.

(ii) **What is the basicity of an acid?**

- This is the number of hydrogen atoms in one molecule of it which are replaceable by a metal.

(iii) Define the following terms.

(a) Normal salt

A normal salt is one in which all of the replaceable hydrogen of an acid has been replaced by a metal or ammonium radical.

(b) Acid salt.

An acid salt is one in which only part of the replaceable hydrogen of an acid has been replaced by a metal or ammonium radical.

(c) Basic salts.

A basic salt is one which contains metal oxide or hydroxide.

(d) Amphoteric substances

These are substances which may act as both acids and bases.

11. (i) What do you understand by hydrolysis of a salt? Give examples.

- Hydrolysis is the reaction of a compound with water such that the hydroxyl group of the latter remains intact.

e.g. Iron III chloride is acidic because of hydrolysis. Hydrated ions are formed from the water.

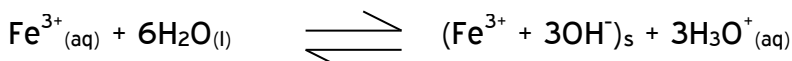
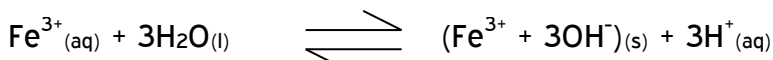
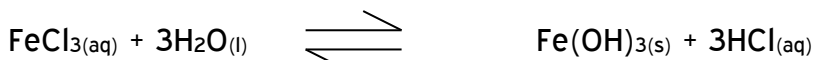

Also – A solution of Na_2CO_3 is alkaline again because of hydrolysis.

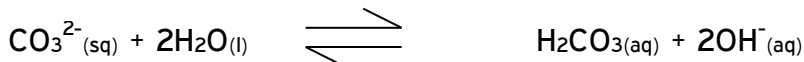
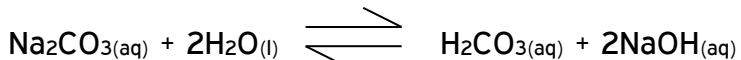

12. Study the equation below and answer the questions that follow:

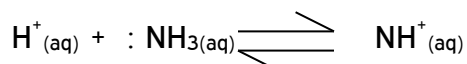

(a) Which of the three species is a lewis base. Explain.

: NH_3 – is a lewis base because it has a pair of electrons while H^+ is a lewis acid for it requires two electrons to attain a stable configuration.

(b) Which of the three species is a base according to theory bronsted – lowry.

: NH_3 – is a base for it is a proton acceptor.

13. (i) The following table shows the PH values of solutions A,B,C and D

Solution	PH value
A	9.8
B	2.0
C	5.2
D	12.0

Which one of the solutions $\text{NaOH}_{(\text{aq})}$, $\text{CH}_3\text{COOH}_{(\text{aq})}$, $\text{HCl}_{(\text{aq})}$ and $\text{NH}_3_{(\text{aq})}$ corresponds to solutions A, B, C and D.

A – $\text{NH}_3_{(\text{aq})}$, C – $\text{CH}_3\text{COOH}_{(\text{aq})}$
 B – $\text{HCl}_{(\text{aq})}$, D – $\text{NaOH}_{(\text{aq})}$

(ii) Explain why sulphuric acid is referred to as a dibasic acid.
 Contains two replaceable hydrogen atoms.

14. A student extracted an indicator from flowers of a plant. The indicator changed red when in aqueous solution of PH 2.7 and yellow at 4.9. Would it be used for titrating dilute hydrochloric acid against dilute sodium hydroxide? Explain.

- No, PH range is narrow and changes only in acidic conditions.

15. A weak base containing a few drops of methyl orange indicator was titrated with a strong acid and the curve below was obtained.

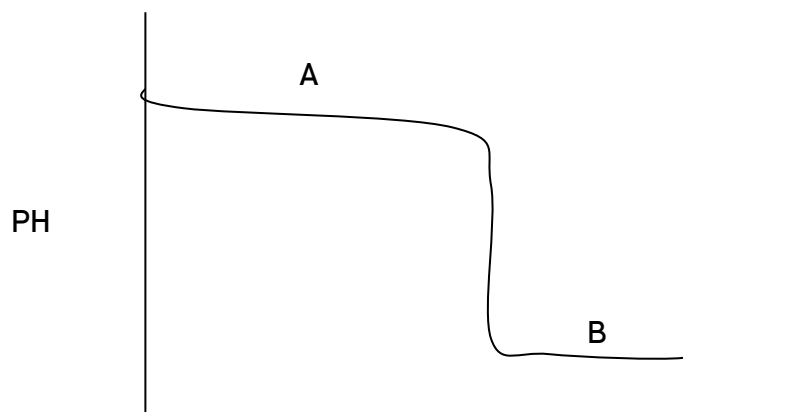

(a) What will be the colour of the indicator at
 (i) A – yellow (ii) B – red

Explain why the PH value decreases.

- Hydroxide ions are removed and the solution becomes acidic.

16. Hydrogen Sulphuric gas is slightly soluble in water. The reaction is given by the equation below.

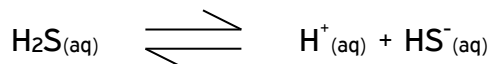

(a) What does the equation above show the behaviour of hydrogen sulphide gas when dissolved in water.

- It is acidic.

(b) Write an equation for the reaction between little solution of hydrogen Sulphide and an excess Sodium hydroxide solution.



17. The graph below shows the changes in PH as sodium hydroxide was added to a solution of hydrochloric acid.

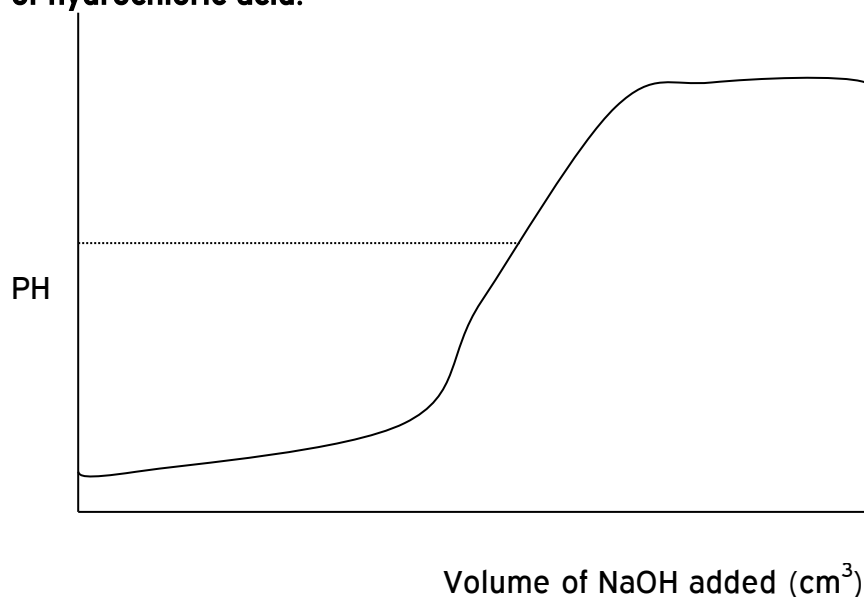

(a) Explain what happens at B.

- Complete neutralisation of hydrochloric by Sodium hydroxide occurs.

(b) What would be the colour of:

(i) Methyl orange at A?

Pink

(ii) Phenolphthalein at C?

Red

18. Explain why dilute Sulphuric acid is a stronger acid than the concentrated one.

- Since strength depends on the degree of ionisation, then it follows that the completely and in this case it is dilute Sulphuric acid. Therefore dilute Sulphuric acid is stronger than the concentrated one ($\text{H}_2\text{SO}_{4(\text{l})}$).

19. What do you understand by the term solubility of a solute in a solvent.

- The solubility of a solute in a solvent is the number of grammes of solute required to saturate 100 grammes of solvent at that temperature.

20. Define the following terms.

(i) Saturated solution.

- Is one which contains as much solute can be dissolved at the temperature concerned, in the presence of undissolved solute.

(ii) Supersaturated solution.

- Is one which contains more solute than a saturated solution at the same temperature.

(iii) Fractional crystallisation.

- Is the process whereby substances are separated by the repeated partial

crystallisation of a solution.

(iv) **Water of crystallisation.**

- Is that definite quantity of water with which some substances are associated on crystallising from an aqueous solution.

(v) **Suspension.**

- Is a mixture of a finely divided solid and a liquid in which it will not dissolve.

21. Study the graph given below on the solubility of Sodium Chloride and Potassium Chlorate and answer the questions that follow:

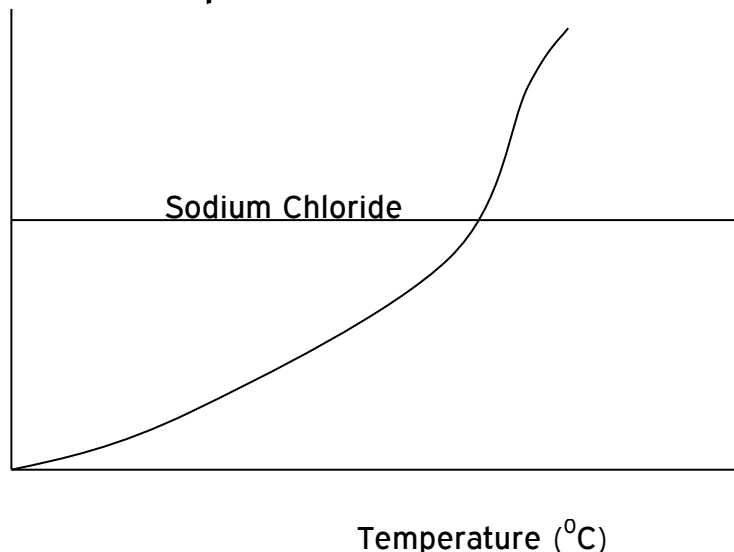

(a) Which of the two salts is less soluble in hot water.

Sodium Chloride

(b) At what temperature are the two salts equally soluble in water?

75°C

(c) State what happens when a mixture of 30g of Sodium Chloride and 30g of Potassium Chlorate (V) in 100 g of water cooled from 100°C to 20°C.

- Crystals of Potassium (V)
- No Sodium Chloride crystals formed.

22. The table below show the solubilities of two salts P and Q at different temperatures.

Temp °C		10	20	30	40	50
Solubility	P	4.6	7.0	9.8	13.0	16.9
In g/100f of water	Q	10.2	14.6	20.1	27.4	25.0

A soluble contained 15g each of P and Q at 50°C. On cooling this solution to 10°C, what total mass of crystals would be obtained.

$$\text{Salt P} - 15.0 - 4.6 = 10.4\text{g}$$

$$\text{Salt Q} - 15.0 - 10.2 = + 4.8 \text{ g}$$

$$\text{Total} = \underline{15.2\text{g}}$$

23. These are three types of solubility curves which can be produced. Study them and give examples for each type.

- (i) Curves for those salts having their solubilities increasing with temperature e.g. KClO_3 KNO_3 etc.
- (ii) Curves for those salts whose solubilities are less in hot than in cold water e.g. CaSO_4 , Ca(OH)_2 etc.
- (iii) Curves for those salts whose solubilities change very slightly with an increase in temperature etc NaCl.

24. Study the information below and answer the questions that follows:

	Solubility in cold water	Boiling point
Ammonium Chloride	Soluble	Sublimes at low temperatures
Potassium nitrate	Soluble	Very high
Lead bromide	Insoluble	Low

Explain how you would obtain a sample of Potassium nitrate from a mixture of the three.

- Filter out Lead bromide salt.
- Crystallise the two soluble salts
- Then carry out sublimation to separate $\text{NH}_4\text{Cl}_{(s)}$ and $\text{KNO}_{3(s)}$

25. Determine the solubility of a substance P in 100cm³ of water at room temperature from the following data.

- (i) Mass of evaporating basin = 25.0g
- (ii) Mass of evaporating basin + Saturated solution of P = 55.0
- (iii) Mass of evaporating basin + Solid P (after evaporating) = 30.0g
N/B: Assume density of water to be 1g/cm³

$$\text{Mass of solution of P} = 55 - 25 = 30\text{g}$$

$$\text{Mass of Solid P} = 30 - 25 = 5\text{g}$$

$$\text{Mass of water} = 30 - 5 = 25\text{g}$$

$$\therefore 5\text{g of P dissolved in } 25\text{g of H}_2\text{O}$$

How many grams will dissolve in 100g of water

$$5\text{g} - 25\text{g of H}_2\text{O}$$

$$x - 100\text{g}$$

$$\frac{500}{25} = 20\text{g}/100\text{g of H}_2\text{O}$$

$$25$$

Therefore the solubility of solid P is 20g/100g of H₂O at room temperature.

26. Briefly comment on the role of the solvent. Give examples to support your answer.

- Solvents help to make substances ionise. On ionisation in the aqueous solutions the same become electrolytes.

E.g. – HCl molecules in water dissociate into hydrogen ions and chloride ions. The hydrogen ions combine with water molecules to form hydroxonium ions, H₃O⁺



- Conversely, the same HCl molecules in methylbenzene remain in their molecular form. Methylbenzene is not a proton acceptor. Consequently, the solution has no effect on litmus, does not react with metals and does not conduct electricity.

PERIODIC TABLE AND ITS DERIVATIVES

1. An element X has atomic number 20 while element Y has atomic number 8.

(a) Write down the electron arrangement for

X - 2 : 8 : 8 : 2

Y - 2 : 6

(b) What type of bond would be formed when X and Y react?

Ionic / electrovalent

2. (a) The grid below represents part of the periodic table. The letters do not represent the actual chemical symbols of the elements.

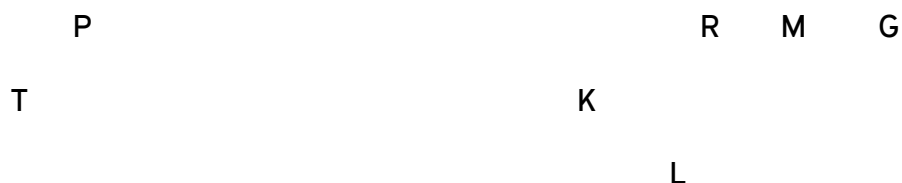

(i) **Select the least reactive element. Explain your answer.**

G – Has stable electronic configuration (2:8:8)

(ii) **What type of structure would the chloride of P have? Explain your answer.**

Giant ionic structure.

(iii) **Which of the element P and G has a larger atomic radius? Explain your answer.**

- P has a greater atomic radius than G
- From P to G nucleus attraction for electrons increases and this decreases size of atom.

(iv) **How does the reactivity of element M compare with that of element L? Explain your answer.**

- M is more reactive than L
- M has a smaller atomic radius and attraction of electrons by its nucleus is greater than that of L.

(b) (i) **It was found that the aqueous solution of an oxide of T has a higher PH value than an aqueous solution of an oxide of R of the same concentration. Explain this observation.**

- T is a metal and reacts with oxygen to form a basic oxide where as R is a non-metal and reacts with oxygen to form an acidic oxide.

(ii) **Would you expect the molten compound formed when P reacts with M conduct electricity? Explain your answer.**

- P is a metal and M is a non-metal
- They react by ionic bonding
- The compound formed is ionic and when in molten state conduct electricity.

3. **The table below gives information on five elements represented by letters Q, R, D, E and G. Study it and answer the questions below.**

Element	Electronic configuration
Q	2:8:1
R	2:8:3
D	2:8:6

E	2:8:8
G	2:7

- (a) (i) Give the formula of the compound formed when Q reacts with D.
 $Q + D \rightarrow Q_2D$
- (ii) What is the type of bonding in the compound formed in (i) above?
 Electrovalent / ionic
- (iii) Draw a dot and cross diagram to show the structure of the compound formed in (i) above?

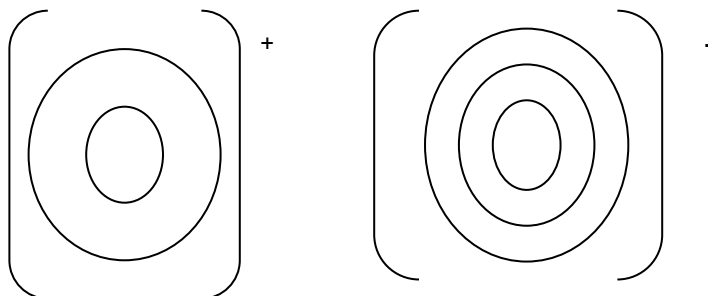

- (iv) Hydrochloric acid reacts with the compound formed in (i) above. Write a balanced chemical equation to show the reaction.

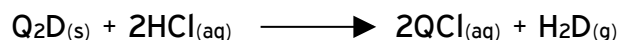

- (v) Predict the reaction between E and Q.
 No reaction
 Give reasons for the answer.
 - Because element E has its outer most energy level completely filled up.

- (b) Given the two particles ${}^{19}_9X$ and ${}^{20}_9X$

- (i) Indicate the number of neutrons in ${}^{19}_9X$

$$\text{neutrons} = 19 - 9 = 10$$

- (ii) Indicate the number of electrons in ${}^{20}_9X$

$$\text{electrons} = 9$$

- (iii) What phenomenon does X show.
 - X is Isotopic
- (iv) A mixture of the two types of X above contains 67% of 19 and 33% of 20. Calculate the

- (ii) Which one of the element will react most vigorously with water? X
 (iii) Write the formular of the compound formed when Y reacts with V

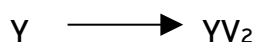

- (iv) Of the two solvents, water and methybenzene which one will be suitable for the compound in (iii) above? Explain your answer.
- Water – A Polar solvent
 - Compound YV_2 is an ionic one and wont dissolve in methybenzene an organic solvent.
- (v) Explain why element R can be conveniently places in both group one as well as in group 7 of the periodic table.
- R – fits in group one since it will loose the only electron to form a positive ion. Just like any other member of the group.
 - It will also fit in group seven as only one (e) electron to attain the noble gas and acquire negative charge just like any member of the halogen family.

7. (a) Study the information in the table below and answer the questions that follow. The letters do not represent the actual symbols of the elements.

Elements	Atomic number	M.P °C	Formular of Chloride	M.P °C Chloride
G	11	98	GCl	801
H	12	650	HCl ₂	715
J	14	1410	JCl ₄	-70
K	16	113	K ₂ Cl ₂	-80
L	20	851	LCl ₂	780

- (i) Which elements are metals? Give a reason.

G: 2:8:1 H: 2:8:2 and L: 2:8:8:2

- From their electronic configuration they can be placed on the left hand side of periodic table – (metallic side)
- The melting point of their chlorides are high helping the presence of an ionic bond in the chlorides and for an ionic bond to be formed there must a metal and non-metal. This bond requires a lot of heat to

break hence high melting points.

- (ii) **Write the formula of the compound formed when element H reacts with element K**

H – 2:8:2

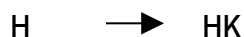

K – 2:8:6

- (iii) **Explain why the melting point of J is higher than that of K.**

J – has a giant atomic structure with very strong covalent bonds which will require a lot of heat (1410) to break while in the case K 113^oC is required to break the simple molecular structure which comes about due to the combination of covalent bonds and weak van der waals forces.

- (iv) **What is the Oxidation state of J in its chloride?**

JCl₄ – total oxidation number = 0

- Every chloride has $\bar{1}$ charge

- Let x be the oxidation number J

$$\therefore x + 4(-1) = 0$$

$$x - 4 = 0$$

$$x = 4$$

J – has an oxidation number of 4 and its chloride

- (v) **How does the:**

I. Melting point of the fluoride of G compare with that of its chloride?

Explain.

- The melting point of the fluoride of G will be slightly higher than that of the chlorides owing to the small size of the ions enabling them approach each closely in the solid crystal. Therefore the ionic bond is stronger in the case of fluorides than in the chlorides. Hence the high melting point.

- (v) **How does the:**

II. Reactivity of H and L with water compare? Give an explanation.

- L will react more vigorously with water as compare to it and water.
- The atomic size of L is larger than that of H, thus making it easy for L to loose its two valency electrons to react with water. In H the atomic size is smaller and the valency electrons are firmly bound by the nucleus thus making the element almost unreactive with cold water.

8. The grid below represents part of the periodic Table. Study it and answer the questions that follow. The letters are not the actual symbols of the elements.

			Q			
O			W	R	S	
T					U	
V					Z	

- (i) Which element will require the least amount of energy to remove one of the outermost electrons? V
- (ii) Select the most reactive non-metal. S
- (iii) Which of the elements has the greatest tendency of forming covalent compound? Explain.
Q – Is in group four and requires a total of four electrons to attain a stable structure. Since it can't lose or gain four electrons, the only alternative it is left with is to share electrons other elements and in so doing it forms covalent bonds with other elements for stability purpose.
- (iv) What name is given to the family of elements to which elements O, T and V belong?
Alkali metals.
- (v) An element W has atomic number 15. Indicate the position of W on the grid.

W – 2 : 8 : 5
Period – 3
Group – 3
Group – 5

on the grid.

- (vi) Explain why the atomic radius of S is smaller than that of R.
- The electrostatic attraction in S is stronger than the R because S has more protons in the nucleus and electrons on the outermost energy level.
As a result S decreases in size.
- (b) Study the information given in the table below and answer the questions that follow.

Formula of compound	NaCl	MgCl	AlCl ₃	SiCl ₄	PCl ₅	SCl ₆
BP ^o C	1470	1420	Sublime s	60	75	60

MP ^o C	800	710		70	90	80
-------------------	-----	-----	--	----	----	----

(i) Give two chloride that are liquids at room temperatures. Give a reason for the answer.

SiCl4 and PCl5

- Are covalent and also have weak Van der Waals forces.

(ii) Give a possible reason why AlCl3 has a much lower melting point than MgCl2 although both AL and Mg are metals.

AlCl3 has some covalency character unlike MgCl2 which is purely ionic hence high melting point.

(iii) Which one of the chlorides would remain in liquid state for the highest temperature range? Show how you arrive at your answer.

9. Complete the table below.

Isotope	Number of		
	Protons	neutrons	electrons
59 CO 27	27	32	27

10. The order of reactivity of metals PR and T starting with the most reactive is R, T, P. By using a tick () to indicate that a reaction occurs and a cross (X) to indicate to reaction, complete the table below to show what happens when the metals are each added to solution containing ions of P, R and T.

Metal	Aqueous solutions containing ions of metal.		
	P	R	T
P	X		
R		X	
T			

11. An element M has a boiling point of 4830^oC and turns in air to form an acidic gas. Suggest a likely structure for element M. Explain your answer.

- Giant covalent / atomic

- A lot of heat will be required to break the strong covalent bonds hence the high boiling of 4830^oC.

12. The table below gives elements represented by letters T, U, V, W, X, Y and their atomic numbers.

Element	T	U	V	W	X	Y
Atomic number	12	13	14	15	16	17

Electron arrangement	2 : 8 : 2	2 : 8 : 3	2 : 8 : 4	2 : 8 : 5	2 : 8 : 6	2 : 8 : 7
----------------------	--------------	--------------	-----------	--------------	--------------	--------------

Use the information in the table to answer the questions below:

(a) Complete the above table by giving the electron arrangement of each of the elements.

(b) In which period of the periodic table do these elements belong? Give a reason.

- They belong to period three
- They have three energy levels each.

(c) How does atomic radius of V compare with that of X? Explain.

- Atomic radius of X is smaller than that of V because electrostatic attraction in X is stronger due to high proton intensity in the nucleus and electrons going to the same orbital.

(d) Give the formula of the compound that could be formed between U and W.

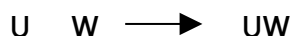

(e) What type of bonding will be present in compound formed T and Y? Explain.

- T Y TY_2 – electrovalent bond.
- The two elements a metal and non-metal and therefore there is a complete transfer electrons. Hence ionic bond.

(f) Arrange the species T, T⁺, T⁻ in increasing order of the size.



(g) Which of the ions X²⁺ and X²⁻ is the most stable? Explain.

- X²⁻ is the most stable because it has the configuration of a noble gas 2 : 8 : 8.

(h) Give the formula of:

- (i) An acidic oxide formed when one of the elements in the table is heated in air.



- (i) A basic oxide formed when one of the elements in the table is heated in air.



13. The electron arrangement of ions X³⁺ and Y²⁻ are 2,8 and 2,8,8 respectively.

(a) Write the electron arrangement of the elements.

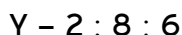
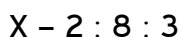

(b) Write the formula of the compound that would be formed between X and Y.

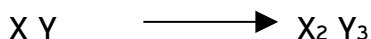

14. The table below gives information on four elements represented by letter K, L, M and N. Study it and answer the questions that follow. The letters do not represent the actual symbols of the elements.

Element	Electro arrangement	Atomic radius (nm)	Ionic radius (nm)
K	2 : 8 : 2	0.136	0.065
L	2 : 8 : 7	0.099	0.181
M	2 : 8 : 8 : 1	0.203	0.133
N	2 : 8 : 8 : 2	0.174	0.099

(a) Which two elements have similar chemical properties? Explain.

K and N – Have the same number of electrons on their outmost energy level and as such their chemical properties are similar since those electrons are the ones involved.

(b) What is the most likely formular of the oxide of L.



(c) Which element is a non-metal? Explain.

L – belongs to the halogen family since it has seven electrons on its outermost energy level. Its ionic radius is larger than the atomic one and this is found in non-metals.

(d) Which one of the elements is the strongest reducing agent? Explain.

M – It has the largest atomic radius and therefore looses its one outermost energy level electron with a lot of ease. Thus it is the strongest reducing agent.

(e) Explain why the ionic radius of N is less than that of M.

N – Ion was formed after atom N loosing two electrons resulting to the shrinking of the ion because the protons are intact. M ion formed after loosing one election. Here the shrinking isn't as pronounced as in N.

(f) Explain why the ionic radius of L is bigger than its atomic radius.

L – is gaining electrons, offseting the balance between electrons and protons. Electrons increase and outnumber the protons and as a result the ionic bulges out abit. Thus increase in the size of the ion.

15. The table below gives the atomic numbers of elements W,X,Y and Z. The letters do not represent the actual symbols of the elements.

--	--	--	--	--

Element	W	X	Y	Z
Atomic number	9	10	11	12

(a) Which one of the elements is least reactive? Explain.

X – 2 : 8 – it is a noble gas configuration.

(b) (i) Which two elements would react most vigorously with each other?

W and Y

(ii) Give the formula of the compound formed when the elements in (i) above react.

YW

16. Study the table below and answer the questions that follow.

Element	Atomic number	R.A.M	MP ^o C
Aluminium	13	27.0	
Calcium	20	40.0	850
Carbon	6	12.0	3730
Hydrogen	1	1.0	-259
Magnesium	12	24.3	650
Neon	10	20	-249
Phosphorus	15	31.0	44.2 (white) 590 (red)
Sodium	11	23	97.8

(a) Complete the table by filling in the missing atomic numbers and atomic mass.

(b) Write the electron arrangement for the following ions:

(i) Ca⁺ - 2 : 8 : 8 : 1

(ii) $P^{3-} - 2 : 8 : 8$

(c) What is the melting point of hydrogen in degree Kelvin?

$$(-259^{\circ}\text{C} + 273)\text{K} = 14\text{K}$$

(d) Which of the two allotropes of phosphorus has a higher density? Explain.

- The red allotrope
- Has a higher $mp^{\circ}\text{C}$ than the white one. The higher the density the higher the intensity of the intermolecular forces and the higher the MP

(e) The mass numbers of the three Isotopes of magnesium are 24, 25, and 26. What is the mass number of the most abundant Isotope of magnesium? Explain.

24 – is nearest to the R.A.M 24.3 and this means it is the most abundant.

(f) Give the formular of the compound formed between aluminium and carbon.



(g) Explain the difference in the melting points of magnesium and sodium.

Both are metals but then the MP of mg is higher because its metallic bond is stronger than in sodium. This strength depends on the number of valency electrons. There more the valency electrons, the stronger the bond.

17. Below is a table of some properties of the chlorides of the elements in period 3. Use it to answer the questions that follow.

Formula or chloride	NaCl	MgCl ₂	Al ₂ Cl ₆	SiCl ₄	PCl ₄	S ₂ Cl ₂	Cl ₂
State at 25^oC	Solid	Solid	Solid	Liquid	Liquid	Liquid	Gas
Boiling point (^oC)	1465	1418	423	57	74	136	-35
Electrical /conductivity in molten state	Good	Good	V. Poor	Nil	Nil	Nil	Nil

(a) Why is the formula of aluminium chloride given as Al₂Cl₆ and not AlCl₃?

- It exists as a dimer.

(b) Explain;

(i) **The variation of states of the chlorides at 25^oC.**

- Chlorides of Sodium and magnesium ionic. Aluminium chlorides is partly ionic and partly covalent from silicon to chlorine the intermolecular forces are weak Van der Waals forces which become minimal at chlorine.

(ii) **The variation of the boiling points of the chlorides.**

- Strong ionic bonds require large energy to break. Weak van der Waals forces require less energy hence the decrease in boiling points.

(c) Write the reactions, if any, which occur when the following chlorides are added to water.

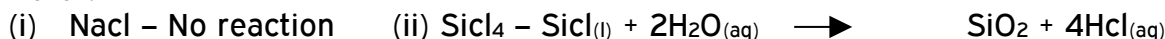

(d) Comment on the PH of the resulting solutions in (c) above.

- (i) PH = 7 (ii) PH = \leq 7 (iii) PH = \leq 7

18. Below is a Time Table of elements represented by letters A to J and their atomic numbers. Use the table to answer the following questions.

Element	A	B	C	D	E	F	G	H	I	J
Atomic number	11	1	17	8	10	12	7	20	2	16

- (a) (i) Which two elements have a valency +1
A and B
- (ii) With reference to the electronic structure, what common feature do the elements in a(i) have?
One electron in the outermost energy level.
- (b) Which two elements belong to group VIII.
E and I
- (c) Select two elements, in each case, which forms ions of the following type.
- (i) X^{2-} D and J
- (ii) X^{2+} F and H
- (d) Select any two elements which form a compound that conducts electricity both in fused state and in solution
A and C
- (e) Select any two elements which when combined and dissolved in water form an acidic solution?
B and C or J and D.

19. (a) Study the table below and answer the questions that follow.

Element	Atomic radius/nm	Ionic radius
A	0.333	0.078
B	0.090	0.120
C	0.157	0.098

- (i) Two of these elements are metals. Which are they?
A and C for (ions are smaller than their parent atoms.
- (ii) Which is the non-metallic element?
How do you know that?
B – Ionic radius is larger than that of the parent atom.
- (iii) The two metallic elements belong to the same group of the periodic table. Which is more reactive? Which one will have greater atomic number?
– Going down a group, the size of the atom as well as that of its ion increases. Hence A is above C in the same metallic group. The reactivity of the metals in a group increases, going down the group. Hence C is more reactive and will have greater atomic number.
- (b) **The table below gives some properties relating to elements in period 3 of the periodic table and its oxides.**

Element	Na	Mg	Al	Si	P
Formula of Oxide	Na ₂ O	MgO	Al ₂ O ₃	SiO ₂	P ₂ O ₅
Atomic radius	1.57	1.36	1.25	1.70	1.10

- (i) **The atomic radii of the elements in the periodic table decrease from left to right. Explain this.**
– Going from left to right of the period, each element has one more electron than the previous element. Notice that this extra electron goes into the same energy level (3rd in this case) and does not cause any increase in the size of the atom. But, the extra positive charge on the nucleus, caused by the extra proton (going from left to right, atomic number increases by 1), increases the attraction of the electrons and makes atoms slightly smaller across the period.
- (ii) **What connection is there between the properties of the oxides and the metallic and non-metallic nature of the elements in this period?**
– Oxides of metals are basic or amphoteric (aluminium oxide); non-metal oxides are acidic with low melting points – most of them are gases. SiO₂ has a giant structure and is a solid with very high melting point. It is an amphoteric oxide.
- (iii) **Which oxides are (i) acidic (ii) basic (iii) amphoteric?**
(i) Acidic oxides – P₂O₅
(ii) Basic oxides – Na₂O and MgO
(iii) Amphoteric oxides – Al₂O₃ and SiO₂
- (iv) **Both Sulphur and Chlorine follow phosphorus in this period. Write the formulae of their oxides.**
SO₂, SO₃ and Cl₂O, Cl₂O₆, Cl₂O₇
- 20.(a) **Why does an arrangement of elements in order of increasing atomic number constitute a periodic table?**
– Chemical properties of elements are periodic function of atomic number.
- (b) **Why are the elements of group 1 of periodic table known as alkali metals?**

- These elements react with water to form alkaline solutions.
- (c) The elements F, Cl, Br, and I are described as halogens, What does this mean and why is it applied to these elements.**
 - A halogen is a salt producer. These elements directly react with metals to form salts.
- (d) Give three reactions of Group 1 elements or its compounds in which all members of the group behave similarly.**
 - All form oxides which react with water to form soluble hydroxides, show a valency of +1. Their hydrogen carbonates are solid and all give flame test.
- (e) Almost all naturally occurring Iron on earth exists as Iron III where as the sample found on the moon is mainly Iron II. Explain.**
 - Oxygen in atmosphere oxidises Iron into Iron III; while the moon has no such atmosphere.

MOLE CONCEPT IN GENERAL

- (i) Gas laws
- (ii) Grahams Law of diffusion
- (iii) The mole
- (iv) Avogadro's number
- (v) Empirical and molecular formulae
- (vi) Percentage composition of a compound.
- (vii) Molar gas volume
- (viii) Atomicity of gases
- (ix) Gay Lussac's Law of combining volume
- (x) Molar Solutions

1. State the following Laws.

(a) Graham's Law.

The rate of diffusion of a gas is inversely proportional to the square root of its density at constant temperature and pressure.

(b) Gay Lussac's Law.

When gases react they do so in small volumes which bear a certain ratio with one another.

(c) Charle's Law.

The volume of a fixed mass of a gas is directly proportional to its absolute temperature at constant pressure.

(d) Boyle's Law.

The volume of a fixed mass of a gas is inversely proportional to pressure at constant temperature.

(e) Avogadro's Law.

Equal volumes of all gases, at the same temperature and pressure, contain the same number of molecules.

(f) Dalton's Law of partial pressures.

If two or more gases, which do not chemically react, are mixed, the total pressure exerted by the gas mixture is equal to the sum of the partial pressures of the component gases, temperature remaining constant.

2. (a) Draw sketchy graphs representing;

(i) Boyle's Law.

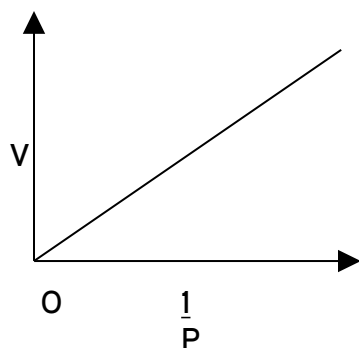

or

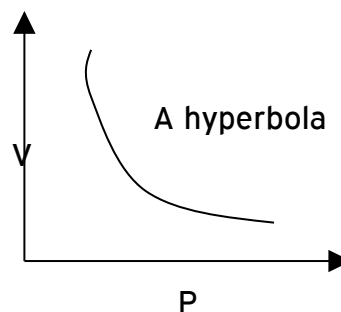

(ii) Charle's Law.

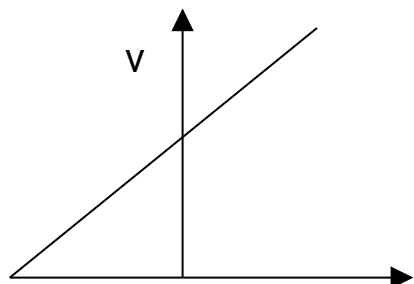

273

T/K

(b) Illustrate

(i) Boyle's Law.

Constant temperature.

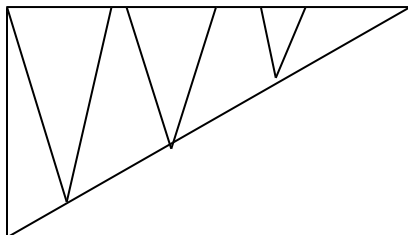
 $C \propto P$ or $PV = \text{constant}$.

(ii) Charles's Law.

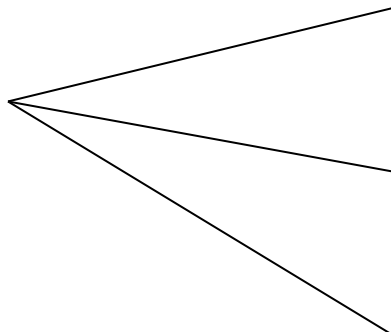
At constant pressure – $V \propto T$ or $\frac{V}{T} = \text{constant}$.

3. At 27°C , nitrogen has a volume of 650cm^3 under pressure of 980mmHg . What would be its volume at the same temperature but at a pressure of 760mmHg ?

$$\begin{array}{lll} \text{At } 27^{\circ}\text{C} & P_1 = 980\text{mmHg} & V_1 = 650\text{cm}^3 \\ & P_2 = 760\text{mmHg} & V_2 = ? \end{array}$$

At the same temperature $P_1V_1 = P_2V_2$ (Boyle's Law)

$$\text{Therefore } V_2 = \frac{P_1V_1}{P_2} = \frac{980 \times 650}{760}$$

$$V_2 = 838.2\text{cm}^3$$

4. Two gases, A and B have densities of 0.18gdm^{-3} and 2.90gdm^{-3} respectively. If they

diffuse under the same conditions, what are their relative rates of diffusion.

By Grahams law $\frac{R_A}{R_B} = \sqrt{\frac{e_B}{e_A}}$ $R_A + R_B$ are rates of gases A and B respectively

$$\left[\frac{R_A}{R_B} \right] = \sqrt{\frac{e_B}{e_A}}$$

$$R_A^2 = \frac{e_B}{e_A}$$

$$= \frac{2.90}{1.18} = 16$$

Therefore $\frac{R_A}{R_B} = 16 = 4$

Therefore, the gas A diffuses four times faster than gas B.

5. In an experiment, it was found that a mole of a gas occupied 24.0dm³ at 20°C and atmospheric pressure. What volume would it occupy at S.T.P?

$P_1 = 1$ atmosphere	$P_2 = 1$ atmosphere
$V_1 = 24.0$ dm ³	$V_2 = ?$
$T_1 = (273 + 20) = 293$ K	$T_2 = 273$ K

$$\frac{P_1 V_1}{T_1} = \frac{P_2 V_2}{T_2} \quad V_2 = \frac{P_1 V_1 T_2}{P_2 T_1}$$

$$= \frac{1 \times 24 \times 273}{1 \times 293}$$

$$= 22.36 \text{ dm}^3$$

$$= 22.4 \text{ dm}^3$$

1Mole of a gas occupies 22.4 dm³ at s.t.p.

6. Rates of diffusion of two gases A and B are in the ratio 2:1. If the molecular mass of gas A is 16g. Find the molecular mass of B.

$$\frac{\text{Rate of diffusion of A}}{\text{Rate of diffusion of B}} = \sqrt{\frac{\text{Molecular mass of B}}{\text{Molecular mass of A}}}$$

$$\frac{2}{1} = \frac{M}{16}$$

$$M = 2 \times \sqrt{16} = 8 \quad \text{hence } M = 8^2 = 64$$

Therefore molecular mass of B = 64g.

7. 100cm³ of a gas at r.t.p was cooled to 60cm³. Calculate the new temperature of the as in °C if the pressure is kept constant.

By Charle's Law. $\frac{V_1}{T_1} = \frac{V_2}{T_2}$

Therefore $\frac{100}{T_1} = \frac{60}{T_2}$

$$298 \text{ T}_2$$

$$\begin{aligned} T_2 &= \frac{60 \times 298}{100} \\ &= 178.8\text{K} \end{aligned}$$

$$\begin{aligned} \ln ^\circ\text{C} &= (178.8 - 273) \\ &= -94.2^\circ\text{C} \end{aligned}$$

8. (i) **What is a mole?.**

A mole is the amount of any substance that contains 6.0×10^{23} particles of that substance.

(ii) **How many grams of Sulphur contain 3.0×10^{21} atoms?.**

6.0×10^{23} atoms are in 1 molar mass of Sulphur 32g.

$$\begin{aligned} 3.0 \times 10^{21} \text{ atoms are in } & \frac{32 \times 3.0 \times 10^{21}}{6.0 \times 10^{23}} \\ &= 16 \times 10^{-2} \\ &= 0.16\text{g} \end{aligned}$$

(iii) **Calculate the number of atoms in 0.027g of aluminium and 48g of carbon.**

$$\begin{aligned} \text{1Mole of AL has } & 6.0 \times 10^{23} \text{ atoms} \\ \text{i.e. 27g of AL has } & \text{''} \\ \therefore 0.027\text{g of AL has } & 6.0 \times 10 \times 0.027 \\ & \frac{27}{27} \\ = \frac{6.0 \times 10^{23} \times 27 \times 10^{-2}}{27 \times 10} & = 6.0 \times 10^{23} \times 10^{-3} \\ = 6.0 \times 10^{20} \text{ atoms} & \end{aligned}$$

(iv) **48g of Carbon**

$$\begin{aligned} \text{1Mole of Carbon has } & 6.0 \times 10^{23} \text{ atoms} \\ \text{i.e. 12g } & \text{''} \quad \text{''} \quad \text{''} \quad \text{''} \\ 48\text{g} & \text{''} \quad \text{''} \quad \text{''} \quad \frac{48 \times 6.0 \times 10^{23}}{12} \\ & = 2.4 \times 10^{24} \text{ atoms.} \end{aligned}$$

(v) **How many electrons will be lost when 1.8g of Magnesium are converted into Mg^{2+} ions?.**

$$\begin{aligned} \text{Mg}_{(s)} & \longrightarrow \text{Mg}^{2+} + 2e \\ \text{1Mole of Mg will loose } & 2 \text{ moles of electrons to become } \text{Mg}^{2+} \text{ ions} \\ \therefore 24\text{g of Mg looses } & 2 \times 6.0 \times 10^{23} \text{ electrons} \\ \therefore 1.8\text{g of Mg will loose } & \\ \frac{2 \times 1.8 \times 6.0 \times 10^{23}}{24} & = 0.9 \times 10^{23} \\ = 9 \times 10^{22} \text{ electrons} & \end{aligned}$$

(vi) **Calculate the number of nitrogen molecules in 560cm^3 of nitrogen gas at s.t.p.**

1mole of N₂ gas molecule occupies 22400cm³ at s.t.p.

∴ 6.0 x 10²³ molecules of nitrogen occupies 22400cm³ at s.t.p.

∴ 560cm³ of nitrogen will have 22400cm³ → 6.0 x 10²³ molecules
 22400cm³ → X molecules

$$\frac{6.0 \times 10^{23} \times 5.6 \times 10^2}{2.24 \times 10^4} =$$

$$6.0 \times 10^{23} \times 4 \times 10^{-2}$$

$$= 6.0 \times 10^{21} \times 4$$

$$= 2.4 \times 10^{22} \text{ molecules.}$$

(vii) **How many calcium ions and how many chloride ions are in 1mole of calcium chloride, CaCl₂?**



∴ 1mole of CaCl₂ contains 1mole of Ca²⁺ ions and 2moles of Cl⁻ ions.

1mole of Ca²⁺ ions = 6.0x10²³ Ca²⁺ ions

2moles of Cl⁻ ions = 2x6.0x10²³
 = 1.2x10²⁴ Cl⁻ ions

(viii) **Calculate the number of ions present in 20g of Ca²⁺ ions.**

40g of Ca²⁺ ions contains 6.0x10²³ ions

∴ 20g of Ca²⁺ will contain

$$6.0 \times 10^{23} \times \frac{20}{40} = 3.0 \times 10^{23} \text{ ions}$$

(ix) **0.5mol of a hydrated salt contains 90g of water. Find the moles of water contained in formula mass of the salt.**

0.5 moles of a hydrated salt contains

90g of water = 90 = 5 moles of H₂O
 18

∴ mole of the same hydrated salt contains $\frac{1}{0.5} \times 5 = 10$ moles of water

(x) **Calculate the percentage of water in Copper (II) Sulphate crystals.**

(Cu = 64, S = 32, O = 64, H = 1).

Formula is CuSO₄.5H₂O

1 atom of Copper, r.a.m 64 = 64

1 atom of Sulphur, r.a.m 32 = 32

4 atoms of oxygen, r.a.m 16 = 64

Total formula mass = 250

$$\text{Percentage of water} = \frac{90}{250} \times 100$$

$$= 36\%$$

(xi) **What mass of Lead (II) nitrate could contain 13g of Lead.**

Formula is Pb(NO₃)₂

Formula mass: 1Pb + 2(N) + 6(O)
 = 207 + 28 + 96 = 33

207(g) of Lead are in 331g of Lead nitrate

13g of Lead are in 331x13
 207

$$= 20.8 \text{ g of Pb (NO}_3)_2$$

9. On heating Sodium nitrate, it decomposes to give Sodium nitrite and oxygen as shown below.



What mass of Sodium nitrate must be heated to give 8g of oxygen.

$$(\text{Na} = 23, \quad \text{N} = 14, \text{O} = 16)$$

If 32g of oxygen are evolved from 170g of NaNO_3 ,

\therefore 8g of oxygen will evolve from

$$\frac{8 \times 170}{32} = 42.5 \text{ g of NaNO}_3$$

10. (i) What is molar gas volume of a gas at s.t.p.?

– The molar volume of any gas is 22.4 dm^3 at standard temperature and pressure.

- (ii) What is atomicity of gases?

– Atomicity of gases is the number of atoms contained in one molecule of a gas.

- (iii) Calculate the volume of oxygen needed for the complete combustion of 200 cm^3 of ethane. What is the volume of the gas formed?

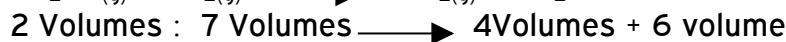
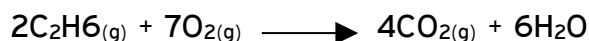
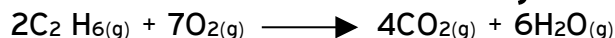

$$200 \quad : \quad 700$$

$$\text{O}_2 = \frac{200 \times 7}{2} = 700 \text{ cm}^3$$

Volume of the gas formed =

Reactants : Products

9 volumes : 10 volumes

Actual volumes : x

$$\therefore 9x = 9000 \quad x = 1000 \text{ cm}^3 - \text{gas formed}$$

$$\text{CO}_2 = \frac{4}{10} \times 1000 = 400 \text{ cm}^3 \quad (\text{Steam}) \text{ H}_2\text{O} = \frac{6}{10} \times 1000 = 600 \text{ cm}^3.$$

11. If the Formulae of Epison salt is $\text{MgSO}_4 \cdot x \text{ H}_2\text{O}$ and the percentage of water is 51.22%. What is the value of X (H = 1 O = 16 Mg = 24 S = 32).

RFM of MgSO_4 is 120g. One molecule of anhydrous salt combines with x molecule of water and since the molecular weight of water is 18, it will be represented as 18x. In 100g of hydrated salt there are 51.22g of water and therefore $100 - 51.22 \text{ g} = 48.78$ of anhydrous salt. Must be the same in one molecule as in 100g.

$$\text{i.e. } \frac{18x}{100} = \frac{51.22}{48.78}$$

$$x = \frac{51.22 \times 120}{48.78 \times 100} \quad x = 7$$

12. Calculate the volume of CO_2 at 20°C and 750mmHg pressure which would be obtained by the action of excess dilute HCl on 5g of calcium carbonate.

From the balanced chemical equation 1mole of calcium carbonate yields 1mole of carbondioxide. 100g of calcium carbonate yields 22.4litres of CO₂. Hence 5g of calcium carbonate will yield 1.12litres this volume of gas being produced at 273k and 760mm/Hg pressure the combined equation to calculate the volume of O₂ that will be produced at 293k and 750mm/Hg = 1.12litres.

13. 50cm³ of m sulphuric acid is added to an excess of solid Sodium hydrogen carbonate. Calculate;

(a) Mass of Sodium Sulphate produced (RFM of Na₂SO₄ is 142g).



1mole of H₂SO₄ yields 142g of Na Sulphate. Hence
 0.05 moles will yield $\frac{0.05 \times 142}{1}$
 = 7.1g of Sodium Sulphate.

14. Given that $\left[\text{H}^+ \right] \left[\text{OH}^- \right] = 1.0 \times 10^{-14}$
 Calculate the hydrogen ions concentration of a solution whose hydroxide ions concentration is;

(a) 0.01 moles

$$\left[\text{OH}^- \right] = 1.0 \times 10^{-2} \quad \therefore \left[\text{H}^+ \right] = 1 \times 10^{-12}$$

(b) 7.3 x 10⁻¹¹ moles

$$\left[\text{OH}^- \right] = 7.3 \times 10^{-11}$$

$$\left[\text{OH}^- \right] \times \left[\text{H}^+ \right] = 7.3 \times 10^{-11} \left[\text{H}^+ \right] = 10^{-14}$$

$$\text{Then } \left[\text{H}^+ \right] = \frac{1 \times 10^{-14}}{7.3 \times 10^{-11}} = 1.37 \times 10^{-4} \quad \left[\text{H}^+ \right] = 1.4 \times 10^{-4} \text{ moles}$$

(c) 3 moles

$$\left[3 \times 10^0 \right] \left[\text{H}^+ \right] = 1 \times 10^{-14}$$

$$\left[\text{H}^+ \right] = \frac{1 \times 10^{-14}}{3 \times 10^0} = \text{Reciprical of } \frac{1}{3} \times 10^{-14}$$

$$\left[\text{H}^+ \right] = 3.3 \times 10^{-15} \quad 0.333 \times 10^{-14}$$

- Given that PH = Log₁₀ H⁺ obtain PH of a solution of which the $\left[\text{H}^+ \right]$ is;

(a) 6.0 x 10⁻² moles

$$\begin{aligned} \text{PH} &= -\text{Log}_{10} \left[\text{H}^+ \right] \\ &= -\text{Log}_{10} (6.0 \times 10^{-2}) \\ &= -(\text{Log } 6.0 + \text{log} 10^{-2}) \\ &= -(0.778 + -2) \end{aligned}$$

$$\text{PH} = 1.22$$

- (b) A detergent solution has a PH of 10.4 at 25°C. What is the concentration of hydroxide ions in the solution at the same temperature?

Solution:

$$\begin{aligned} \text{PH} &= -\log \left[\text{H}^+ \right] \\ \log \left[\text{H}^+ \right] &= -\text{PH} = -10.4 = (-0.4 + 1) + (-10 - 1) \\ &= -0.6 - 11 \quad \text{Ah} + \log \text{ of } 0.6 \end{aligned}$$

$$\left[\text{H}^+ \right] = 10^{0.6} \times 10^{-11} = \underline{3.98 \times 10^{-11} \text{M}} \cong 4 \times 10^{-11} \text{M}$$

$$\begin{aligned} \therefore \left[\text{H}^+ \right] \left[\text{OH}^- \right] &= 1 \times 10^{-14} \quad \left(4 \times 10^{-11} \right) \left[\text{OH}^- \right] = 1 \times 10^{-14} \\ \left[\text{OH}^- \right] &= \frac{1 \times 10^{-14}}{4 \times 10^{-11}} \\ &= \text{Reciprical of } \frac{1}{4} \times 10^{-14} \times 10^{11} \\ &= 0.25 \times 10^{-3} \\ &= 2.5 \times 10^{-4} \text{M} \end{aligned}$$

15. Wabongo prepared Barium (II) Sulphate from Barium hydroxide and dilute sulphuric acid 10cm³ of the acid were added to the alkali at intervals. The electrical conductivity was plotted against the volume of acid used and the graph shown below was obtained.

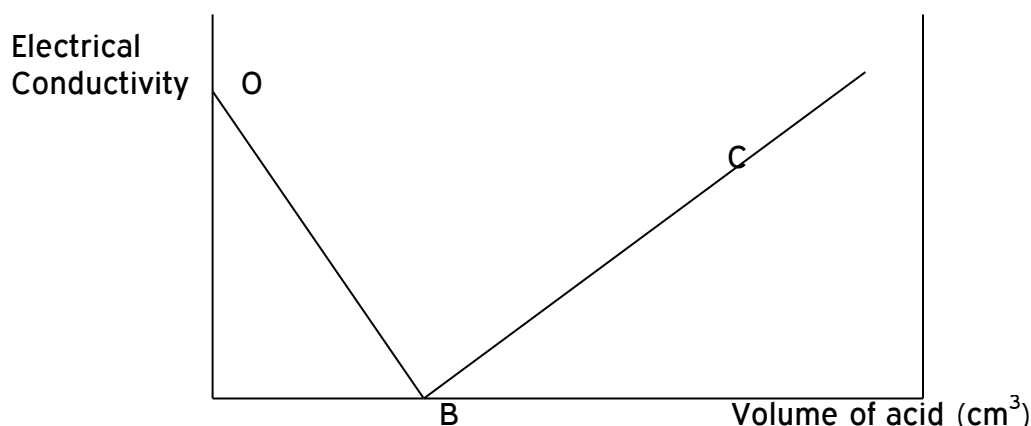

- (i) What ions are responsible for electrical conductivity at points O and C respectively.

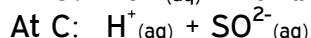
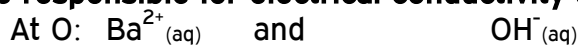

- (ii) Why does the electrical conductivity decrease from O to B and increase from B to C?

- From O to B: $\text{Ba}^{2+}_{(\text{aq})}$ and $\text{OH}^{-}_{(\text{aq})}$ are removed from the solution by forming $\text{BaSO}_{4(\text{s})}$, and H_2O respectively.
- From B to C: Excess acid.

- (iii) What happens at B?

- Complete neutralisation of the alkali has taken place.

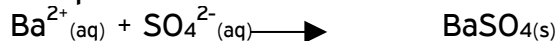

16. How many grams of copper oxide will be formed by heating 16g of copper in oxygen (Cu = 63.5) (O = 16).

- (a) Start by the balanced equation for the reaction 20g

- (b) How many grams of Hydrogen will be prepared to reduce the copper oxide formed in (a) above.

From the balanced equation for the reaction 1mole of CuO react with 1mole of hydrogen therefore 20g of it will be reduced by

$$\frac{20 \times 2}{79.5} = 0.503\text{g}$$

(c) What mass of water will be formed?

From the balanced equation for the reaction 1mole of CuO form 1mole of water. If 79.5g of CuO form 18g of water then 20g of it will form.

$$\frac{20 \times 18}{79.5} = 4.53\text{g}$$

17. Calculate the percentage of O₂ in copper II nitrates (Cu = 63.5, N = 14, O = 16)
= 51.2%

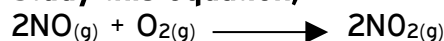
18. Study this equation;

If 40cm³ of oxygen and 40cm³ of nitrogen monoxide are allowed to react. What will be their;

- (a) Volume of O₂ that remains unused.

By Gay Lussac's Law, 2 volumes of No react with one volume of O₂ therefore 40cm³ of No react with 20cm³ of O₂.

- (b) Volume of Oxygen that remains unused.

$$20\text{cm}^3$$

- (c) Volume of Nitrogen dioxide produced.

$$40\text{cm}^3$$

- (d) Final volume of the mixture.

This will be the volume of the unreacted gas plus the volume of nitrogen dioxide gas.
This will be 60cm³.

19. What is the mass of copper II flouride.

$$(\text{F} = 19 \quad \text{Cu} = 63.5) \quad 204\text{g}$$

20. 62g of an oxide of a metal M were formed when 4.6g of the metal reacted with an excess of oxygen write the formulae of the metal oxide (M = 23, O =16).

21. How many moles of flourine atoms are there in one mole of flourine molecules.

$$2\text{moles}$$

22. Calcium combines with O₂ according to the following equation.



Calculate the mass of calcium needed to react completely with 160g of O₂ (Ca = 40, O = 16).

From the equation for the reaction of O₂ combine with 80g of calcium therefore 160g of O₂ will combine with;

$$\frac{160 \times 80}{32} = 400\text{g of calcium}$$

23. A fixed mass of a gas occupies 150cm³ at 15°C 1.8 atmospheres. What volume will it occupy at s.t.p.

$$213\text{cm}^3 \text{ use the combined gas Law.}$$

24. 1M calcium carbonate when heated decomposed yielding 22.4 litres. What volume of the gas will be produced at s.t.p on decomposing 0.5 moles of calcium carbonate.

$$(\text{Ca} = 40, \quad \text{O} = 16, \quad \text{C} = 12) \quad 11.2 \text{ litres}$$

25. In an experiment 25 cm³ of a solution containing 26.8g per litre of sodium carbonate completely neutralising 27cm³ of hydrochloric acid.

a) Write an equation for reaction.



b) What is the molarity of the hydrochloric acid

0.468 use the relationship.

$$\frac{\text{Molarity of acid} \times \text{volume of acid}}{\text{Molarity of acid} \times \text{volume of carbonate}} = \frac{\text{No. of moles of acid}}{\text{No. of moles of carbonate.}}$$

26. Lead (II) carbonate was added, a little at a time to 50cm³ of 3M nitric acid until no further change was observed. The mixture was then filtered.

(i) Write down the ionic equation for the reaction.

Write down the normal equation for the reaction separate all the substances in a gaseous states, cancel the spectator ions 1-e that are in the same state and form on the reactant and product and you will be left with the ionic equation;

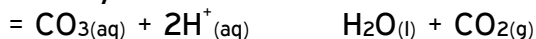

27. 25cm³ of 0.1 Sulphuric required 20cm³ of Sodium carbonate solution for complete neutralisation. Calculate the concentration of the Sodium carbonate in moles per litre.

0.125M

28. Calculate the concentration in (moles per litre) of a solution containing 0.4 sodium hydroxide in 100cm³ of water. (Na = 23, O = 16, H=1)

0.1M

29. 40cm³ of N gas is reacted with 140cm³ of H gas using a catalyst in a closed system.

(i) Write an equation for the reaction.

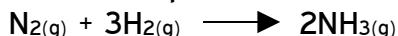

(ii) Calculate the volume of the residual.

80cm³ of ammonia and 20cm³ of unused hydrogen.

30. (i) How many atoms, do 1.5moles of calcium contain? (r.a.m of Ca = 40).

1mole of Ca contains 6.02x10²³ atoms.

1.5moles contain 6.02x10²³ x 1.5 atoms

$$= 9.03 \times 10^{23} \text{ atoms}$$

(ii) What is the mass in grams of 3.01x10²³ atoms of calcium?

The molar mass of Ca is 40g mol⁻¹

∴ 6.02x10²³ atoms of Ca have a mass of 40g

3.01x10²³ atoms of Ca have a mass

$$\frac{40 \times 3.01 \times 10^{23}}{6.02 \times 10^{23}} = 20\text{g}$$

31. (i) Compound K has the following properties of elements in percentage.

40.0% calcium

12.0% Carbon

48.0% oxygen

What is its empirical formula?

(R.a.m of Ca = 40, C = 12, O = 16)

Ca	:	C	:	O
40%		12%		48%

$$\frac{40}{40} = 1 \qquad \frac{12}{12} = 1 \qquad \frac{48}{48} = 3$$

∴ The empirical formula is CaCO_3

- (ii) A compound X has a mass of 58g and its empirical formula is C_2H_5 . Find its molecular formula. (C = 12, H = 1).

$$\text{Mass of } (\text{C}_2\text{H}_5)_n = 58$$

$$29n = 58$$

$$n = \frac{58}{29}$$

$$n = 2$$

Therefore the molecular formula of X is;

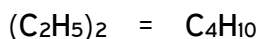

32. 0.32g of oxygen at s.t.p occupy 0.224 litres

- (i) Calculate its relative formula mass.

Molar gas volume at s.t.p = 22.4L

0.32g occupies 0.224L

How many grams will 22.4L have?

$$0.32\text{g} \longrightarrow 0.224\text{L}$$

$$X \longrightarrow 22.4\text{L}$$

$$\frac{0.32 \times 22.4}{0.224} = 32\text{g}$$

- (ii) How many molecules, by Avogadro's number does 0.32g of oxygen gas have?

32g has 6.02×10^{23} molecules

$$32\text{g} \longrightarrow 6.02 \times 10^{23} \text{ molecules}$$

$$0.32\text{g} \longrightarrow$$

$$= \frac{0.32}{32} \times 6.02 \times 10^{23}$$

$$= 6.02 \times 10^{21} \text{ molecules}$$

MOLAR SOLUTIONS

33. (i) Calculate the molarity of a solution containing 3.71g of sodium carbonate, Na_2CO_3 , per litre. (C = 12, O = 16, Na = 23).

Formula mass of $\text{Na}_2\text{CO}_3 = 106$

1mole of sodium carbonate = 106

$$\therefore 3.71\text{g of } \text{Na}_2\text{CO}_3 = \frac{3.71}{106} = 0.035 \text{ mole}$$

∴ The solution is 0.035M Na_2CO_3

- (ii) Calculate the molarity of a solution containing 3.12g of copper(II) sulphate crystals, $\text{CuSO}_4 \cdot 5\text{H}_2\text{O}$. 250 cm^3 of solution. (H=1, O = 16, S = 32, Cu = 63.5)

Molar mass of $\text{CuSO}_4 \cdot 5\text{H}_2\text{O} = 249.5\text{g}$

$$3.12\text{g of } \text{CuSO}_4 \cdot 5\text{H}_2\text{O} = \frac{3.12}{249.5} = 0.0125 \text{ moles}$$

250 cm^3 of solution contains 0.0125 moles one litre (1000 cm^3) of solution contains

$$4 \times 0.0125$$

$$= 0.05 \text{ mole}$$

Therefore the molarity of the solution = 0.05M

- (iii) Calculate the number of moles of sodium chloride present in 100cm³ of a 2M solution.
1000cm³ of solution contain 2moles

$$\therefore 1000\text{cm}^3 \text{ of solution contain } \frac{100}{1000} \times 2 = 0.2\text{moles}$$

$$= 0.2\text{moles}$$

- (iv) Calculate the mass of Sulphuric acid in 250cm³ of a 0.2M H₂SO₄ solution.

Molar mass of Sulphuric acid = 98g

1mole of sulphuric acid = 98g

$$\text{No. of moles in 250} = \frac{250 \times 0.25}{1000} = \frac{0.25}{4} \text{ moles}$$

$$\begin{aligned} \text{Mass in 250} &= \text{No. of moles} \times 98 \\ &= \frac{0.25}{4} \times 98 \\ &= 6.125\text{g} \end{aligned}$$

- (v) Work out the molarity of a solution containing 3.2g of Sodium hydroxide in one litre of the solution:

$$\begin{aligned} \text{Molarity} &= \frac{\text{Conc. Gdm}^{-3}}{\text{R.F.M}} = \frac{3.2}{40} = 0.08\text{M} \\ \text{Or } \frac{\text{mass per litre}}{\text{R.F.M}} \end{aligned}$$

TITRATION SAMPLE QUESTIONS

Choice of indicators

This depends on the strength of both the base and the acid.

- (i) When titrating weak acid against strong alkalis, e.g. Use phenolphthalein indicator for the following.

- Ethanoic acid
 - Butane dioic acid (Succinic)
 - Methanoic acid
 - Carbonic acid
 - Sulphuric acid
- Vs NaOH

- (ii) When titrating weak alkalis against strong acids e.g.

- Ammonia
 - Sodium carbonate
 - Sodium Borate
- Vs HCl or H₂SO₄

The methyl orange (red

- (iii) When titrating a strong alkali against a strong acid e.g.

NaOH Vs H₂SO₄ – Use any indicator

- (iv) When titrating a weak acid against a weak base e.g. ethanoic acid against ammonia.
Use methyl red.

The table below shows the colour changes of some common indicators

Indicator	pH range	In acid	In alkali
Methyl orange	3.0 – 4.4	Red	Orange
Methyl red	4.4 – 6.3	Red	Yellow
Litmus	6.0 – 8.0	Red	Blue
Phenolphthalein	8.2 – 10	Colourless	Red

34. Sample 1**You are provided with;**

- Solution W which contains 3.56g of HCl per litre.
- Solution B contains 6.3g of $(\text{COOH})_2 \cdot n\text{H}_2\text{O}$ per litre of solution
- Sodium hydroxide – solution C

You are required to;

- (i) Standardise solution C
- (ii) Determine the value of n in the formula $(\text{COOH})_2 \cdot n\text{H}_2\text{O}$

Procedure 1

Place solution C in the burette using a pipette. Transfer 25.0cm^3 of solution A into a conical flask, add two drops of phenolphthalein indicator and titrate with solution C until a permanent change is obtained. Record your results in table 1 below. Repeat the procedure to get three readings.

Table 1

	1 st	2 nd	3 rd
Final reading (cm^3)	25.0	26.9	28.9
Initial readings (cm^3)	0.0	2.0	4.0
Titre volume (cm^3)	25.0	24.9	24.9

Treatment of results

(a) Determine the average volume of solution C used. (1mk)

$$\frac{25.0 + 24.9 + 24.9}{3} = \frac{74.8}{3} = \underline{24.93\text{cm}^3}$$

(b) Calculate the concentration of solution A in moles per litre (H = 1, Cl = 35.5). (1mk)

$$\begin{aligned} \text{No. of moles} &= \frac{\text{Mass}}{\text{R.F.M}} = \frac{3.56}{36.5} = 0.0098 \\ &= 0.01 \text{ moles} \end{aligned}$$

(c) Calculate the concentration of solution C in moles per litre (H = 1, Na = 23, O = 16).

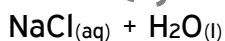
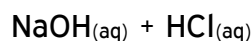

$$1 : 1$$

$$M_b V_b = M_a V_a$$

$$1000 \quad 1000$$

$$\text{No. of moles of HCl} = \frac{25.0 \times 0.1}{1000} = 0.0025$$

It follows \therefore No. of moles of NaOH = 0.002

$$\begin{aligned} \text{Molarity} \therefore &= \frac{\text{No. of moles} \times 1000}{\text{Volume}} \\ &= \frac{0.0025 \times 1000}{24.93} = 0.100 \\ \text{Conc} &= 0.100 \text{ moles/L} \end{aligned}$$

Procedure II

Wash the pipette and conical flask. Pipette 25.0cm³ of solution B and transfer it into a conical flask. Add 2-3 drops of phenolphthalein indicator and shake. Titrate this solution against solution C in the burette. Obtain three readings and record your results in table II below.

Table II

	1 st	2 nd	3 rd
Final Burette reading (cm ³)	24.9	27.0	28.0
Initial Burette readings (cm ³)	0.0	2.0	3.0
Titre volume used (cm ³)	24.9	25.0	25.0

(a) Determine the average volume of solution C. (1mk)

$$\frac{24.9 + 25.0 + 25.0}{3} = \frac{74.9}{3} = 24.97 \text{ cm}^3$$

(b) Calculate the number of moles of sodium hydroxide contained in the average volume. (2mks)

$$\begin{aligned} \text{Moles of NaOH in } 24.97 \text{ cm}^3 &= \frac{24.97 \times 0.100}{1000} = 0.002497 \\ &= 0.0025 \end{aligned}$$

(c) Calculate the moles of the acid B contained in the 25.0cm³ of solution B. (1½ mk).

Mole B : C

1 : 2

$$\therefore \text{Moles of B} = \frac{0.0025}{2} = 0.00125 \text{ moles}$$

(d) What is the concentration of solution B in moles per litre? (1½).

$$\begin{aligned} 25 \text{ cm}^3 \text{ contain } 0.00125 \text{ moles of B} \\ \therefore 1000 \text{ cm}^3 &= \frac{1000 \times 0.00125}{25} = 0.05 \text{ moles} \end{aligned}$$

(e) Calculate the Relative formula mass (R.F.M) of the acid. (2mks)

$$\therefore \text{Conc.} = 0.05 \text{ moles / litres.}$$

$$0.05 \text{ moles weigh } 6.3\text{g}$$

$$\therefore 1 \text{ mole} = \frac{1}{0.05} \times 6.3\text{g}$$

$$= 126\text{g}$$

(f) Determine the value of n in the formula.

$$(\text{COOH})_n \cdot n\text{H}_2\text{O} = (12 + 32 + 1) \times 2 + 18n = 126$$

$$= 90 + 18n = 126$$

$$18n = 126 - 90 = 36$$

$$n = \frac{36}{18} = 2$$

$$n = 2$$

$$n = 2$$

35. SAMPLE QUESTIONS II

To determine water of crystallisation.

- You are provided with solution B₁₀ and B₁₄ solution B₁₀ is a hydrated Sodium carbonate (NaCO₃.XH₂O). Prepare by dissolving 9.536g of hydrated sodium carbonate in water and making it to 500cm³. B₁₄ is 0.1667M HCl.

Procedure

Place 25cm³ of solution B₁₀ in 250cm³ beaker and add 2 – 3 drops of indicator. Place solution B₁₄ in the burette and titrate against the B₁₀ solution until the pink colour just disappears.

Pipette volume 25.00cm³

Burette readings

	Trial	1 st	2 nd	3 rd
Final burette readings	20.20	19.90	20.10	20.00
Initial burette readings	0.00	0.00	0.00	0.00
Volume of B ₁₄ used	20.20	19.90	20.10	20.00

(a) Calculate the mean titre in cm³.

$$\frac{19.90 + 20.10 + 20.00}{3} = \frac{60}{3} = \underline{20\text{cm}^3}$$

(b) Calculate No. of moles of B₁₄ used. (3mks)

$$\frac{20.0 \times 0.1667}{1000} = 0.003334 \text{ moles}$$

(c) Write the equation for the reaction. (3mks)

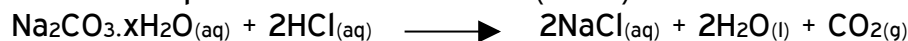

(d) Calculate the No. of moles of Sodium Carbonate in 25.0cm³. (2mks)

Reacting mole Na₂CO₃ : HCl

$$1 : 2$$

$$\therefore \text{No. of moles of Na}_2\text{CO}_3 = 0.003334 \times \frac{1}{2}$$

$$= 0.001667 \text{ moles}$$



(H = 1.00, O = 16.0, S = 32.0, C = 12.0)

Results

The volume of the pipette used was 25cm³

Burette readings

	Trial	1 st Titration	2 nd	3 rd
Final reading (cm ³)	25.80	25.10	35.80	42.30
Initial readings (cm ³)	0.70	0.40	11.20	17.70
Volume A used (cm ³)	25.10	24.70	24.60	24.60

Calculate the mean in titre in cm³

$$\frac{24.70 + 24.60 + 24.60}{3} = 24.63\text{cm}^3$$

(i) Calculate the molarity of solution A (H₂SO₄).

$$\text{Molarity} = \frac{\text{Mass of one litre}}{\text{Molar mass}} = \frac{9.80}{98} = 0.100\text{m}$$

(ii) Calculate the molarity of solution B (X₂CO₃).

$$\begin{aligned} \text{No. of moles of H}_2\text{SO}_4 \text{ in } 24.6\text{cm}^3 \text{ of} \\ 0.1\text{M solution} &= \frac{0.10 \times 24.6}{1000} \end{aligned}$$

$$\therefore \text{No. of moles of X}_2\text{CO}_3 \text{ in } 25.0\text{cm}^3 = \frac{0.10 \times 24.6}{1000}$$

$$\therefore \text{No. of moles of X}_2\text{CO}_3 \text{ in } 1000\text{cm}^3$$

$$\frac{0.10 \times 24.6 \times 1000}{1000 \times 25.0}$$

Solution B is 0.0984M

(iii) Calculate the formula mass of X₂CO₃.

0.0984 moles of X₂CO₃ contains 13.8g

$$\therefore 1\text{mole of X}_2\text{CO}_3 \text{ contains } \frac{13.8}{0.0984} = 141\text{g}$$

$$\therefore \text{Formula mass of X}_2\text{CO}_3 = 141\text{g}$$

(iv) Calculate the relative atomic mass of X.

Let formula mass X₂CO₃ = 2X + (12.0 + 48.0)

$$2x + 60.0 = 141$$

$$2X = 141 - 60 = 81$$

$$\therefore X = \frac{81}{2}$$

$$= 40.5 \text{ (atomic mass of X)}$$

CARBON AND ITS DERIVATIVES

1. (a) What is meant by 'allotropy'?

- This is the existence of an element in more than one physical form.

(b) Name the allotropes of carbon.

- Diamond
- Graphite

(c) State what you understand by amorphous carbon and list down forms of the same.

- Amorphous carbon is the non-crystalline form of carbon which consist of minute fragments of graphite.

- (i) Wood charcoal – (from wood)
 - (ii) Sugar charcoal – (obtained by dehydrating)
 - (iii) Animal charcoal – (from animal bones)
 - (iv) Lamb black – (from hydrocarbon such as petroleum, turpentine etc)
 - (v) Soot – (Found on chimneys)
 - (vi) Coke – (From destructive distillation of coal)
- (d) State the use of each of the form in (c) above.
- (i) Wood charcoal –
 - (i) Source of energy
 - (ii) Used to absorb poisonous gases in urinals and in the gas masks in war fronts.
 - (ii) Animal charcoal – Used to remove brown colour from crude sugar (brown sugar).
 - (iii) Lampblack – used to manufacture shoe polish, carbon paper, Indian ink and printers ink and car tyres.
 - (iv) Coke – Used in blast furnaces, ovens and bottles.
 - Used as a reducing agent in the extraction of Iron, Zinc and Lead metals from their oxides.

2. By considering the structures of the allotropes, explain why;

- (i) Graphite conducts electricity but diamond does not.
 - In diamond each carbon atom is using its four bonding electrons to form covalent bonds to four other atoms. In graphite, each carbon atom is bonded to only three others, even though four electrons are available for bonding. The extra electrons are free to move from one hexagon to the next within a layer and thus conduct an electric current.
- (ii) Graphite is soft but diamond is hard.
 - Graphite is made up of layers of hexagon of carbon atoms. The bonding in each layer strong but the layers are only held together by Weak Van da Waal's forces. The layers of carbon atoms can thus slide easily over one another. However, in diamond all the bonds are very strong.
- (iii) Graphite has a much lower density than diamond.
 - Although both allotropes consist entirely of carbon atoms, graphite has a more open structure than that of diamond and hence has a lower density.
- (iv) Both substances have high melting points.
 - This is because they both consist of giant structures of atoms.

3. (a) Explain what is meant by the term 'Isotopy' and list three isotopes of carbon.

- Isotopy is the existence of atoms of the same element with the same atomic number but different mass number.
- Isotopes of carbon are; Carbon ${}_{6}^{12}\text{C}$ and Carbon ${}_{6}^{13}\text{C}$ and
- Carbon ${}_{6}^{14}\text{C}$

- (b) State the use of carbon ${}_{6}^{14}\text{C}$ (C – 14).
 - Carbon – 14 is used for carbon dating exercises in which the age of materials many thousands of years old can be accurately dated.
- (c) Carbon has two main Isotopes ${}_{6}^{13}\text{C}$ and ${}_{6}^{12}\text{C}$, with abundancies of 1.11% and 98.89% respectively. Calculate its relative atomic mass.

Relative atomic mass = Mass due to

^{13}C + Mass due to ^{12}C

$$= \left(\frac{13 \times 1.11}{100} \right) + \left(\frac{12 \times 98.89}{100} \right) = \underline{\underline{12.01}}$$

(d) What name of the instrument used to measure the atomic masses of elements.

Mass spectrometer

- It separates the isotopes of an element and the determination of their respective masses.

4. List four different fuels of carbon and briefly explain how each is formed.

(i) Wood – Occurs naturally and 50% of it is carbon.

(ii) Coal gas – obtained from the destructive distillation of coal

- It is a mixture of methane, carbon monoxide and hydrogen.

(iii) Producer gas – Obtained by passing air over red-hot coke in a furnace. The reaction is exothermic.

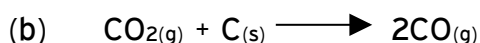
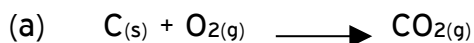

NB – The mixture of $\frac{1}{3}$ carbon monoxide by volume and the unchanged nitrogen from the air forms the producer gas.

(iv) Water gas – is produced by passing steam over white hot coke (above 1000°C) in a furnace. A mixture of equal volumes of carbon monoxide and hydrogen is formed.

5. (a) Describe how you would prepare and collect CO_2 in the lab.

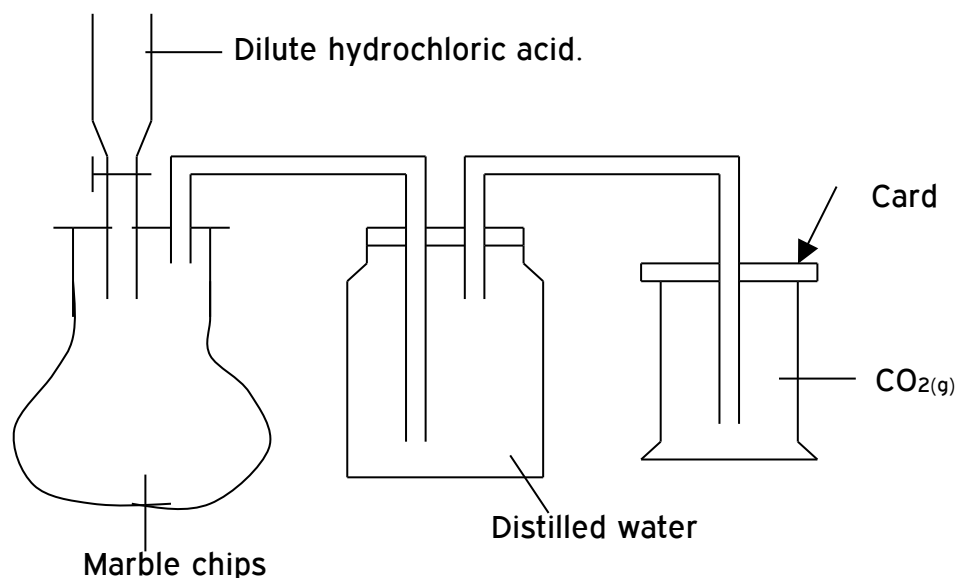

- Dilute hydrochloric acid is added to marble chips. The gas given off is passed through water to remove acid sprays ($\text{HCl}_{(g)}$) and is then collected by downward delivery as shown above.

(b) Give the equation for the reaction.



- (c) State **two** ways in which the rate of reaction could be increased.
- (i) The rate could be increased by using more concentrated acid or smaller pieces of marble.
- (d) (i) What do you observe if carbon dioxide is passed into lime water for several minutes?
- The limewater turns milky i.e. a white precipitate is formed and then a clear solution is formed.
- (ii) By use of chemical equations explain these observations.
- White precipitate is formed which is calcium carbonate.

$$\text{CO}_2(\text{g}) + \text{Ca}(\text{OH})_2(\text{aq}) \longrightarrow \text{CaCO}_3(\text{s}) + \text{H}_2\text{O}(\text{l})$$
 - White precipitate disappears and a clear solution is formed.

$$\text{CaCO}_3(\text{s}) + \text{H}_2\text{O}(\text{l}) + \text{CO}_2(\text{g}) \longrightarrow \text{Ca}(\text{HCO}_3)_2(\text{aq})$$

Clear
- (e) There would have been little reaction if sulphuric acid had been added to marble chips. Explain.
 Calcium sulphate is produced and as this is insoluble it forms a layer around the marble chips and stops the reaction.

6. (i) State six uses of carbon dioxide.

- (i) Fire extinguishers – for CO_2 is denser than air and doesn't support combustion.
 - (ii) Used in aerated or fizzy drinks e.g. mineral water.
 - (iii) Used in refrigeration – solid carbon dioxide or 'dry ice' is used as a refrigerant. It is used for keeping ice-cream cold and to deep freeze food.
 - (iv) Baking – Baking powders consist of a mixture of 2,3 – dihydroxybutanedioic acid and sodium hydrogen carbonate. In presence of water they react to form carbon dioxide, which cause the dough to rise.
 - (vi) Solvay process – in the manufacture of sodium carbonate.
- (ii) Give **two** ways in which carbon dioxide is added to the air.
- Carbon dioxide is added through combustion of substances such as coal and petroleum and through respiration.
- (iii) Give **two** ways in which carbon dioxide is removed from the air.
- Photosynthesis and the dissolving of carbon dioxide in water remove the gas from the atmosphere.

7. Explain the following observations.

- (a) Why is dry ice a better refrigerant than ordinary ice?
- The solid sublimates when warm leaving no residue.
- (b) When a lighted splint is plunged into a gas jar containing carbon dioxide gas, it goes off.
- Carbon dioxide does not support combustion hence it extinguishes a burning splint.
- (c) When a piece of burning magnesium is lowered into carbon dioxide in a gas jar, it continues burning with a spluttering flame and black specks are formed on the sides of the gas jar and white deposit is seen in the jar.
- Magnesium has a high affinity for oxygen it splits carbon dioxide into oxygen and combines with it to form MgO , the white solid observed) and carbon, a black solid will be deposited.

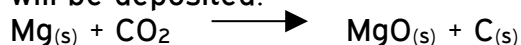

(d) State the uses of the following;

- (i) Diamond – Used as a gemstones owing to its sparkling nature and due to its hardness, in making of cutting tools and rock borers.
 (ii) Graphite – Used as a lubricant due to its slippery nature, as moderator the atomic reactors, as an electrical conductor (because each carbon atom in graphite has a delocalised electron that can more and conduct the electric current) and in making pencil leads.
 (iii) Used as a reducing agent as shown below.



- (iv) Carbon monoxide – Used in the manufacture of ethanol and as a reducing agent in the extraction of metals such as Iron, copper, lead etc from their oxides.

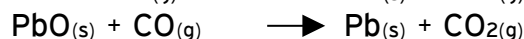
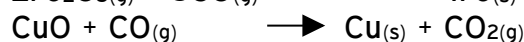

8. When pure carbon dioxide is passed over heated solid Y, carbon monoxide is formed as the only product. Study the diagram below and answer the questions that follow.

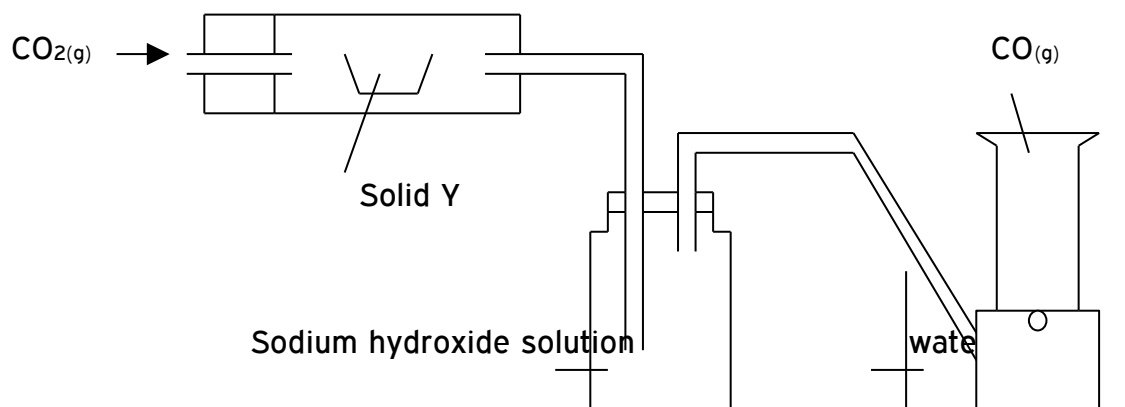

(a) Name solid Y.

Carbon

(b) Why is sodium hydroxide used in the experiment?

– To absorb carbon dioxide.

(c) Name two reagents that could be used to prepare carbon dioxide.

Calcium carbonate and dilute hydrochloric acid.

(d) Name two pairs of reagents that could be used in preparing carbon monoxide, writing the equation for the reaction that occur.

– Concentrated sulphuric acid and oxalic acid (N.B this reaction involves dehydration of oxalic acid).

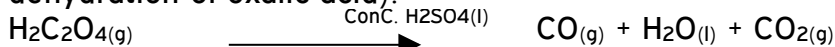

– Concentrated sulphuric acid and sodium ethanoate.



(a) Would you expect the compound formed between silicon and chlorine to conduct the electric current?

– No, it is not an ionic compound.

(b) Write the formula of the oxide silicon. – SiO_2

(c) How can you obtain the element silicon from its oxide? Give an equation for the reaction.

- By heating silicon dioxide in an electric furnace with carbon.

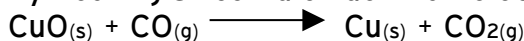

(d) The oxide of silicon is found in the blast furnace during the production of iron. What is the source of this oxide and how is it removed.

- Source: as an earthly impurity. It is removed by fusing with silicon dioxide:

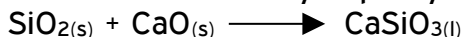

(e) How is the reaction of the silicon compound (Na_2SiO_3) shown below different from its equivalent carbon compound?.



- Acid react with carbonates to form a salt, water and carbon dioxide. The compound above reacts with an acid to form another acid and a salt.

(f) What is the test for carbon monoxide?

- Carbon monoxide burns in air with a blue flame forming a colourless gas that turns lime water cloudy (carbon dioxide).

9. Two gas jars, one containing carbon monoxide and another containing carbon dioxide were both inverted over water and the results shown below were obtained.

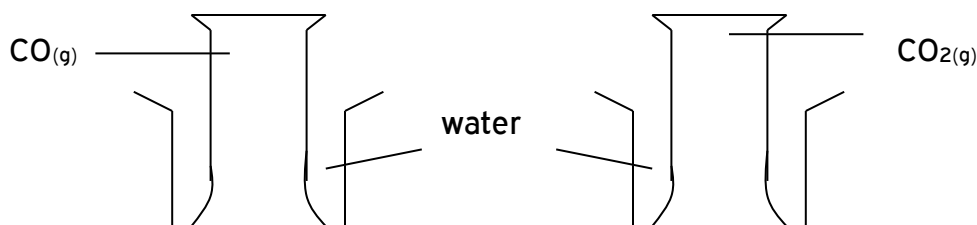

(a) What can you conclude from the above observations.

- Carbon monoxide is insoluble in water whereas carbon dioxide is sparingly soluble in water.

(b) What observations would you have made if water was replaced by sodium hydroxide?

No observable change occurs in A whereas in B, the level of sodium hydroxide solution rose even to a much higher level than shown. This is because carbon monoxide does not dissolve in sodium hydroxide but carbon dioxide, an acidic oxide, readily dissolves in it.

10. Silicon is an element below carbon in group IV of the periodic table and has a valency of 4 in all its compounds. Use your knowledge of the chemistry of carbon to answer the following questions.

11. Carbon monoxide gas is passed over a heated metal oxide and an excess of carbon dioxide is absorbed in a suitable absorbing solution Y.

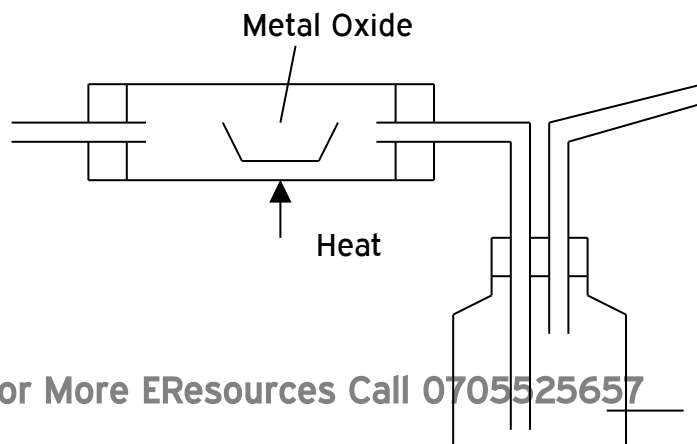

- (a) Name the metal oxides that can be used as X.
Lead II Oxide, Copper II Oxide and Iron III Oxide.
- (b) Name the appropriate solution that can be used as Y.
– Ammoniacal copper I chloride.

12. Trona, a naturally occurring substance in alkaline lakes such as Lake Magadi is used in production of sodium carbonate.

- (a) How is trona formed?
– Trona is formed as a result of springs, flowing from volcanic area L. Magadi joining to form streams and rivers that flow into the Lake with no outlet. Heat from the sun together with the generally high temperature at the Lake causes the water in the lake to evaporate leaving behind the trona.
- (b) What is the composition of trona?
Trona is double salt of sodium carbonate and sodium hydrogenate carbonate, $\text{Na}_2\text{CO}_3 \cdot \text{NaHCO}_3 \cdot 2\text{H}_2\text{O}$, mixed with some sodium chloride.
- (c) What is the main source of power that is used at L. Magadi? Mention the problems associated with this source of power.
The main source of power that is used at L. Magadi is liquid fuel. The combustion of this fuel produces pollutants such as sulphur dioxide gas that are released.
L. Magadi is about 130km away from Nairobi so transportation of liquid fuel is expensive.
- (d) Discuss the chemical reactions and conditions involved in the production of sodium carbonate from trona.
– The trona is dug from the Lake using a bucket dredger, crushed, mixed with water and then pumped to the factory. At the factory, slurry trona is then washed in a washery. The slurry trona then fed into the centrifuges where moisture content reduced to about 3% from the centrifuges the trona is fed into container where it is calcified at a temperature of 500°C and trona is converted into crude soda. Water, carbon dioxide (and some organic impurities) are removed. The main reaction that occurs in the container can be represented by the equation.
$$2\text{Na}_2\text{CO}_3 \cdot \text{NaHCO}_3 \cdot 2\text{H}_2\text{O}_{(s)} \longrightarrow 3\text{Na}_2\text{CO}_3_{(s)} + \text{CO}_{2(g)} + \text{H}_2\text{O}_{(g)}$$

– The sodium carbonate is then cooled, dissolved in water and filtered to remove impurities. The filtrate is passed through activated carbon to remove soluble organic impurities. The filtrate is evaporated under pressure to cause crystallisation of sodium carbonate monohydrate. The monohydrate crystals are washed and calcified at 150°C to produce anhydrous sodium carbonate.
$$2\text{NaHCO}_3 \cdot 2\text{H}_2\text{O}_{(g)} \quad \text{Na}_2\text{CO}_3_{(s)} + \text{H}_2\text{O}_{(g)} + \text{CO}_{2(g)}$$

The water used for washing is taken through a series of shallow ponds where the water is evaporated by the sun, sodium chloride obtained from the water in the ponds by fractional crystallisation.

13. How is carbon dioxide obtained industrially.

- On a large scale carbon dioxide is obtained by;

- (i) Burning coke in air.
- (ii) As a by-product in the preparation of ethanol.

14. (i) State the advantage that graphite has over other lubricants.

- Graphite has a high melting point hence can be used as a lubricant at a high temperature.

(ii) Graphite has a lower density compared to diamond and is more reactive than diamond.

- Graphite has a more structure compared to diamond.

(iii) Explain how carbon monoxide is lethal when one inhales?

- Carbon monoxide with haemoglobin to form cherry – red carboxyhaemoglobin. This is much more stable than oxyhaemoglobin and thus the blood can no longer act as an oxygen carrier. Consequently the organism dies of suffocation since oxygen carrier in the blood stream has been incapacitated.

15. (i) What happens to all insoluble carbonates when heated?

- All insoluble metallic carbonates decomposes on heating, e.g. calcium, Zinc, Copper carbonates give carbon dioxide and their corresponding metallic oxides.



(ii) Comment on the effect of heat on soluble metallic carbonates.

- No observable change no matter how strong how long these carbonates are (K_2CO_3) to Na_2CO_3 .

(iii) What is the test for all carbonates?

- All carbonates will react with dilute acids to liberate carbon dioxide gas that turns Limewater milky.

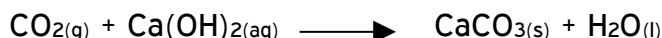
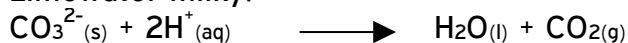

White ppt.

(iv) List the uses of five named carbonates.

1. Sodium carbonate – used to soften has water.
2. Calcium carbonate – used for making cement.
3. Basic Lead (II) carbonate $\text{Pb}(\text{OH})_2 \cdot 2\text{PbCO}_3$ – used in the manufacture of some paints.
4. Sodium hydrogencarbonate is used for buildings, decorations and monuments as well as in cement production.
5. Potassium carbonate – in making of hard glass.

16. a) When carbon dioxide is bubbled through water the product turns blue litmus to red.

Explain this observation.

Answer

Carbon dioxide is an acidic gas it dissolves in water to form a weakly acidic solution

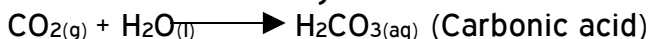

(b) Burning magnesium were lowered into a gas jar of carbon dioxide.

- (i) What would you see? Explain.
- (ii) Write an equation for the reaction.

Answer

- (i) Black specks of carbon and a grey white residue. The intense heat of burning magnesium decomposes carbon dioxide to carbon (black specks and oxygen). The oxygen released keeps the magnesium burning to produce magnesium oxide (white powder)

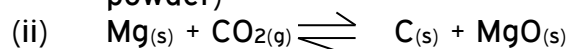

17. (i) Below is a diagram of a luminous flame from bunsen burner. Label diagram fully.

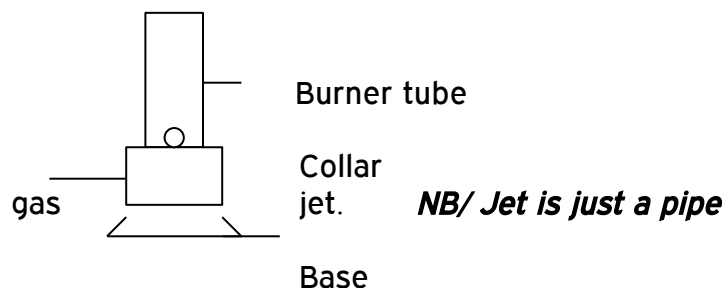

(ii) State at least two differences between a luminous and a non- luminous flame.

Answer

- (i)
 - I. Almost colourless mantle
 - II. Bright yellow zone
 - III. Dark Central zone
 - IV. Blue Zone.

Luminous flame	Non-Luminous flame
<ul style="list-style-type: none"> - Cool sooty flame - Large part of flame is yellow - Blue zone is very small 	<ul style="list-style-type: none"> - Much hotter and cleaner flame - Large part of flame is an almost colourless zone - Blue zone is much bigger

18 (a)(i) Carbon monoxide burns in air. Write equation of reaction.

(ii) The reaction;

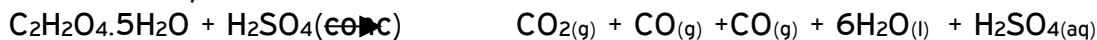

- I. How is the carbon monoxide formed separated and collected from this reaction.
- II. State two properties of carbon monoxide.

Answer

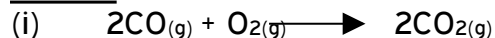

- (ii)
 - I. Pass the gaseous products through sodium hydroxide solution and collect Carbon monoxide over water.
 - II. Carbon monoxide is neutral to litmus paper and only slightly soluble in water.
 - Carbon monoxide is poisonous.

(b) In an experiment gas Y was passed over heated charcoal and product passed over heated Iron (III) Oxide. Gases were then passed through lime water which formed a white

precipitate. Gas left burned with a blue flame at a jet.

- (i) Identify gas Y
- (ii) Write the equation of reaction between
 - I. Gas Y and charcoal
 - II. Iron and product from reaction with charcoal
- (iii) The charcoal and iron were in separate porcelain boats. What was seen in each case.

Answer

- (i) Gas Y is Carbon dioxide
 - (ii) I. $\text{CO}_{2(g)} + \text{C}_{(s)} \longrightarrow 2\text{CO}_{(g)}$
 II. $\text{Fe}_2\text{O}_3 + 3\text{CO}_{(g)} \longrightarrow 2\text{Fe}_{(s)} + \text{CO}_{2(g)}$
 - (iii) The charcoal disappeared as it formed gas and the brown iron(III) Oxide formed a shiny greyish solid.
- (c) Below is a diagram of a coke fire. Study it and answer the questions that follow.

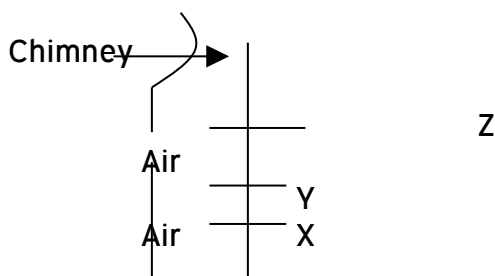

- (i) Write an equation for reaction in each of the regions X, Y and Z.
- (ii) What is seen at Z?
- (iii) Why is it not advisable to light a charcoal "jiko" in a poorly ventilated room.

Answer

- (i) $\text{C}_{(s)} + \text{O}_{2(g)} \longrightarrow \text{CO}_{2(g)}$ (X)
 $\text{CO}_2 + \text{C} \longrightarrow \text{CO}_{(g)}$ (Y)
 $2\text{CO}_{(g)} + \text{O}_2 \longrightarrow 2\text{CO}_{2(g)}$ (Z)
- (ii) A blue flame
- (iii) Such a fire will produce carbon monoxide which is poisonous and may lead to death in a poorly ventilated room.

(d) Carbon can be used to reduce oxides of lead and copper

- (i) Write the equations of reaction
- (ii) What would be seen in each case.

Answer

- (i) $\text{C}_{(s)} + 2\text{CuO}_{(s)} \longrightarrow 2\text{Cu}_{(s)} + \text{CO}_{2(g)}$
 $2\text{PbO}_{(s)} + \text{C}_{(s)} \longrightarrow 2\text{Pb}_{(s)} + \text{CO}_{2(g)}$
- (ii) The black copper oxide changes to a red brown shiny solid.
 and the yellow solid changes to a grey shiny solid.

4. Below is a flow diagram of the stages for manufacturing sodium carbonate in Solvay process.

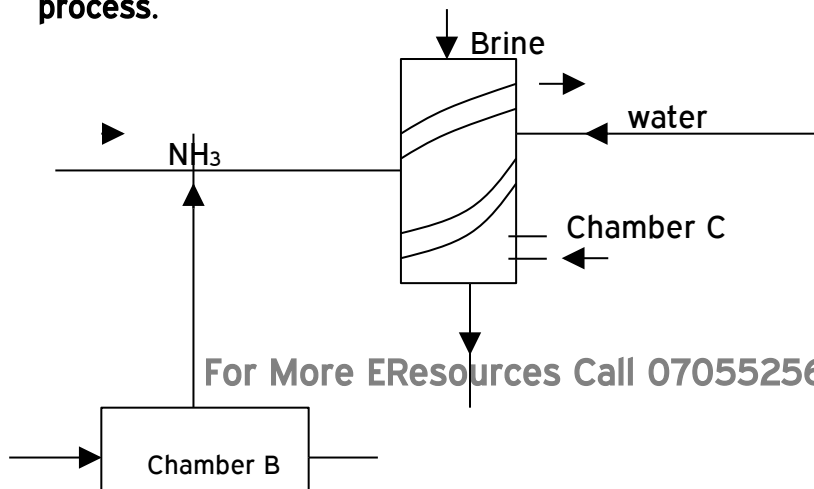

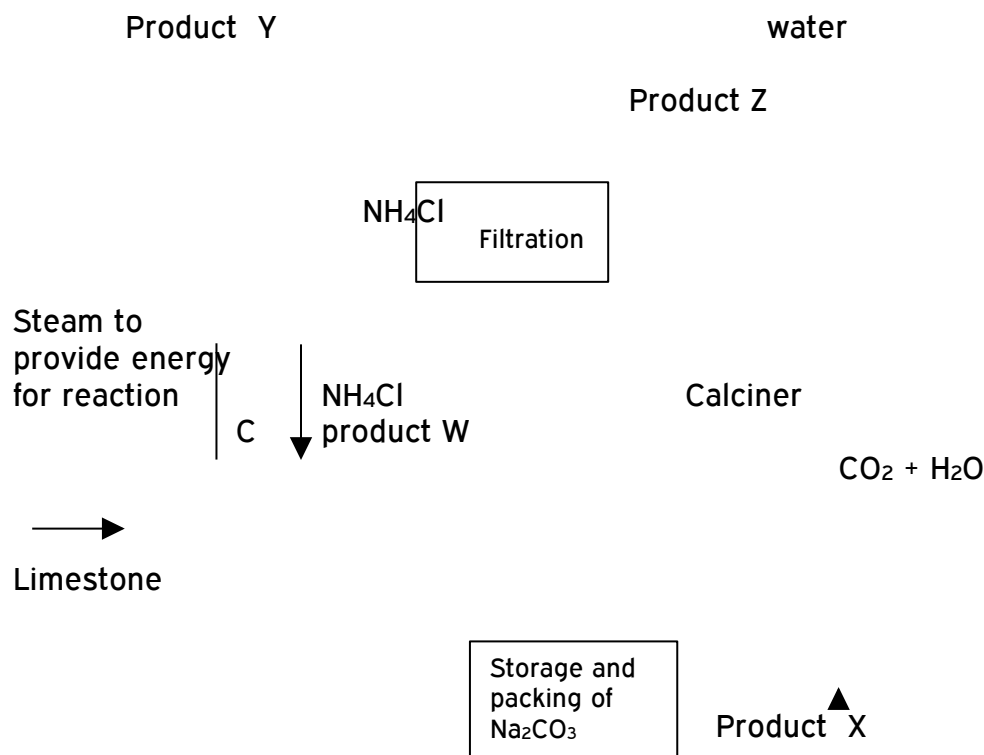

- (a) (i) State the products W, X, Y and Z.
 (ii) State what happens in chambers A, B and C fully.

Answer

- (i) W = CaCl_2 , X = Carbon dioxide
 Y = ammonia, Z = mixture of NaHCO_3 and NH_4Cl
 (ii) In A, CaCO_3 is decomposed by heating to produce CaO and CO_2 .
 In B, ammonium chloride reacts with CaO to produce NH_3 and CaCl_2
 In C, Brine is mixed with other reagents to produce NaHCO_3 and NH_4Cl . A lot of heat is produced and hence the need to circulate cold water round the chamber.
 (b)(i) Explain what happens in the calciner using an equation.
 (ii) Name the compounds recycled.

Answer

- (i) Sodium hydrogencarbonate is decomposed by heating.

$$2\text{NaHCO}_3 \longrightarrow \text{Na}_2\text{CO}_{3(s)} + \text{CO}_{2(g)} + \text{H}_2\text{O}_{(l)}$$

 (ii) Ammonia, Carbon dioxide and water.

(c)(i) What property of Sodium hydrogen carbonate enables its separation from ammonium chloride?

(ii) What property of reaction in chamber C makes it necessary to circulate cold water round it?

(iii) Identify **three** exothermic and three endothermic reactions in the Solvay process.

Answer

- (i) Sodium hydrogen carbonate has a low solubility therefore it precipitates.
 (ii) Reaction is exothermic
 (iii) Exothermic reactions

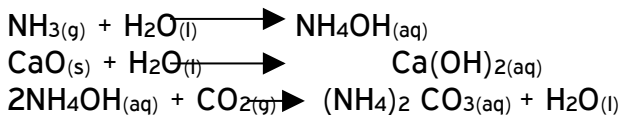
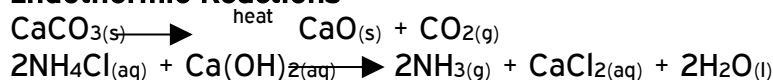
**Endothermic Reactions**

- (d) (i) Write the equation of reaction in chamber C.
 (ii) Considering the reactants, circulated by-products and the final products.
 I. Write the overall equation of reaction in the Solvay process.
 II. Why is the reaction not done directly.

Answer

II. Insoluble Calcium carbonate cannot react with Sodium Chloride.

- (e) From 1.50 tonnes of salt mixed with other reactants, 1 tonne of impure soda ash was produced.
 (i) If the soda ash is 58% pure calculate the mass of pure, sodium carbonate.
 (ii) What is the percentage conversion of sodium chloride to soda ash.
 (iii) Give one reason why yield may be low.

Answer

- (i) Impure soda ash is 1.0 tonne

$$\begin{aligned} \text{Pure soda ash} &= \frac{58 \times 1.00}{100} \\ &= 0.58 \text{ tonne} \end{aligned}$$

- (ii) $2\text{NaCl} = 1 \text{Na}_2\text{CO}_3$
 i.e. see d(ii) or other relevant equation.

$$\text{Na}_2\text{CO}_3 = 23 \times 2 + 12 + 48 = 106$$

$$\text{NaCl} = 23 + 35.5 = 58.5$$

$$2\text{NaCl} = (58.5 \times 2) = 117$$

Mass of Na_2CO_3 expected from 1.5 tonnes

$$= \frac{106 \times 1.5}{117} \text{ tonnes}$$

$$= 1.36 \text{ tonnes}$$

But actual yield = 0.58 tonnes

$$\text{Therefore percentage yield} = \frac{0.58}{1.36} \times 100\% = 42.6\%$$

- (iii) Not all the Sodium hydrogen carbonate remains as precipitate. Some dissolves.

5. The following is an outline of the Carbon cycle. Study it and answer the questions that follow.



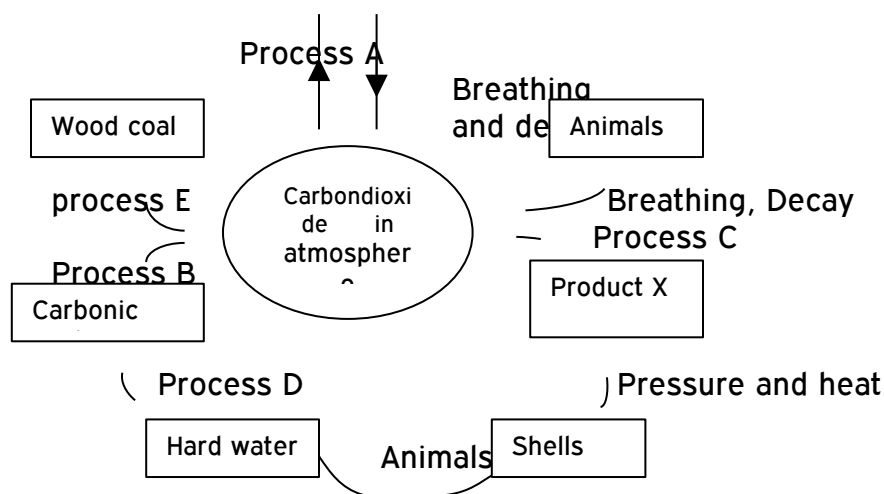

(a) State processes A, B, C, D and E

Answer

(a) A is photosynthesis

B is dissolution of CO₂ in water

C is Heating

D is a reaction to form a hydrogen carbonate with carbonic acid.

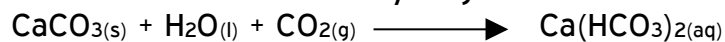

E is burning of wood or coal.

(b)(i) Name product X

(ii) Explain how product X produces carbon dioxide

Answer

(i) Limestone, chalk or marble

(ii) It is decomposed by heat



(c) State **two** ways in which breathing is related to process C.

Answer

- Both use Oxygen and release CO₂
- Both processes produce energy.

(d) State **six** elements in coal

Answer

Carbon, hydrogen, Oxygen, nitrogen, Phosphorus and sulphur.

(e) Use the correct terms to describe:

(i) Two processes that remove carbon dioxide from the air

(ii) Three processes that add carbon dioxide into the atmosphere.

Answer

(i) Photosynthesis and dissolution of CO₂ into the sea

(ii) Burning of wood and coal

Heating of carbonate rocks to decompose

Breathing and decay

PRACTICE QUESTIONS

1. a) The arrangement below was used to study the reducing action of gas X.

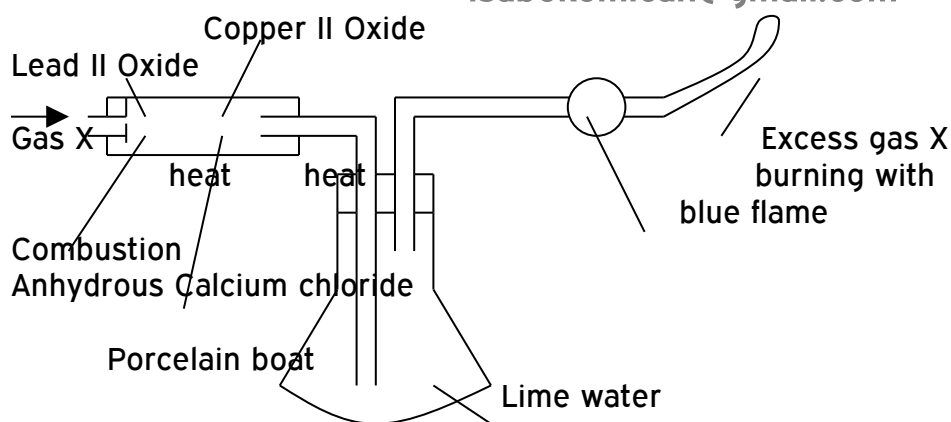

- Lime water in conical flask formed a white precipitate. What is the identity of gas X.
- What is observed on each oxide in combustion tube
- Write equations of reactions between gas X and heated oxides in boats?
- What is the purpose of anhydrous calcium chloride.
- Name another gas that burns with a blue flame and write an equation for its combustion.

(b) Table below is a record of incomplete observations on heating carbonate and hydrogen carbonates in a test tube.

Carbonate	Observation
Magnesium carbonate	
Zinc carbonate	
Lead carbonate	Crackling sound, gas forms white precipitate with limewater. Yellow residue but brown when hot.
Copper carbonate	

- Complete the table
 - Write equation of reaction for the effect of heat on each of the three carbonates.
- (c) The arrangement below is an incomplete table of tests on residue obtained on heating carbonates and hydrogen carbonates.

Carbonate / Hydrogen carbonate	Residue in crucible	Residue added to water and stirred and tested with litmus	Adding dilute Hydrochloric acid to residue
Calcium	White		

carbonate	residue		
Sodium carbonate			Effervescence
Lithium carbonate	White residue	Solution turns red litmus blue	No effervescence
Sodium hydrogen carbonate			
Calcium hydrogen carbonate			

- (i) Complete the table
- (ii) Write equation of reaction (if any) for each of carbonate or hydrogen carbonate.
- (iii) What is the common name for
- I. Sodium carbonate
 - II. Sodium hydrogen carbonate
 - III. Calcium carbonate
 - IV. Calcium oxide
 - V. Calcium hydroxide solution
 - VI. Calcium hydroxide
- (iv) To carry out the heating of calcium carbonate, a strong open flame was used in the following arrangement.

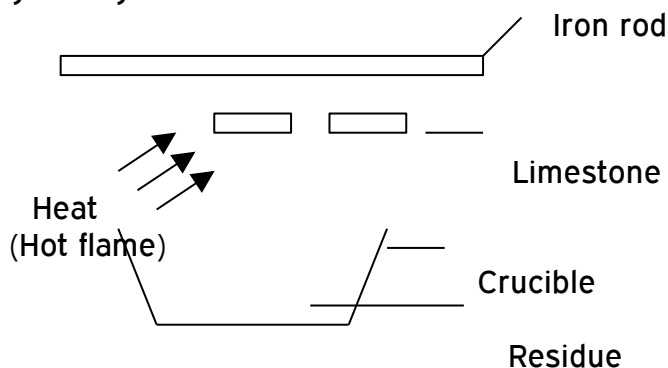

Why do we need a strong open flame to heat calcium carbonate?

- (d) State **two** uses of
- (i) Sodium carbonate
 - (ii) Sodium hydrogen carbonate.

(Q2) Below is a passage describing how Sodium chloride is obtained from Lake Magadi in the Rift Valley. Study it and answer questions that follow.

Lake Magadi consists of massive deposits of trona ($\text{Na}_2\text{CO}_3 \cdot \text{NaHCO}_3 \cdot 2\text{H}_2\text{O}$) a crystalline solid. This solid material has formed as a result of the high rate of evaporation on this water mass with high salt content. Below the trona is a mother liquor of Sodium chloride and Sodium carbonate with a density of $1.26 \times 10^3 \text{ kg m}^{-3}$.

The less soluble salt crystallises out first. This knowledge is made use of in separation of dissolved solids; a process known as fractional crystallisation. Sodium chloride and sodium carbonate have the same solubility at 36.1°C but sodium chloride is more soluble below this temperature while sodium carbonate is more soluble above this temperature.

During the process of obtaining sodium chloride mother liquor is made to flow into channels and then pumped into salt fields where initial evaporation by solar energy occurs. These are the pre-concentration ponds where the liquor flows from one pond to another by gravity. Precipitation of trona and sodium carbonate monohydrate occurs.

Eventually the concentration of common salt equals that of sodium carbonate and the two form 16% of the mother liquor. The liquor is pumped into salt making ponds where further evaporation occurs.

During hot months of the year the daily temperatures of this liquor can be as high as 40°C but generally below 36.1°C. During night temperatures average 20°C. Because of the difference in solubility of salt and carbonate and the high variation of temperatures between day and night, the two deposit at different times. Impure salt is obtained which is purified by washing with saturated sodium chloride solution. The purified salt is then iodised to produce coarse salt. Some of the coarse salt will be treated by adding red oxide (Iron (II) Oxide for cattle.

Coarse salt contains 99.5% NaCl, 0.03% NaF, 0.4% sodium carbonate and 0.0037% iodine.

- What is the mass of water in 1000kg of mother liquor with density of $1.26 \times 10^3 \text{kgm}^{-3}$?
- What does the precipitation of trona and sodium carbonate monohydrate in the pre-concentration ponds tell you about the relative concentration of sodium carbonate compared to sodium chloride in the lake?
- What is the mass of sodium chloride in 1000kg of mother liquor when concentration of salt equals concentration of sodium carbonate?
- Which of the two is precipitated during day, sodium chloride or sodium carbonate?
- Write formula of;
 - Sodium carbonate monohydrate
 - Sodium hydrogen carbonate
 - Sodium fluoride
 - Iodine
- To make 1000kg of coarse salt how much
 - Sodium chloride sodium fluoride and sodium carbonate would be weighed?
 - Iodine would be weighed?
- State two other uses of sodium chloride?
- Sketch solubility curves for sodium chloride and sodium carbonate against temperature using the table given on the grids below;

Temperature (°C)	0	10	20	30	40
Solubility in grams of solute in 100g					
(i) Sodium carbonate	7.0	12.5	21.5	40.1	48
(ii) Sodium chloride	35.7	35.8	36.0	36.2	36.5

Q3. (a) (i) What is allotropy

(ii) Explain how carbon is able to make marks on paper and at the same time scratch marks on glass.

(b) Coke is a form of carbon obtained when coal is heated strongly in absence of air (carbonized). Study the reaction scheme below and answer the questions that follow.

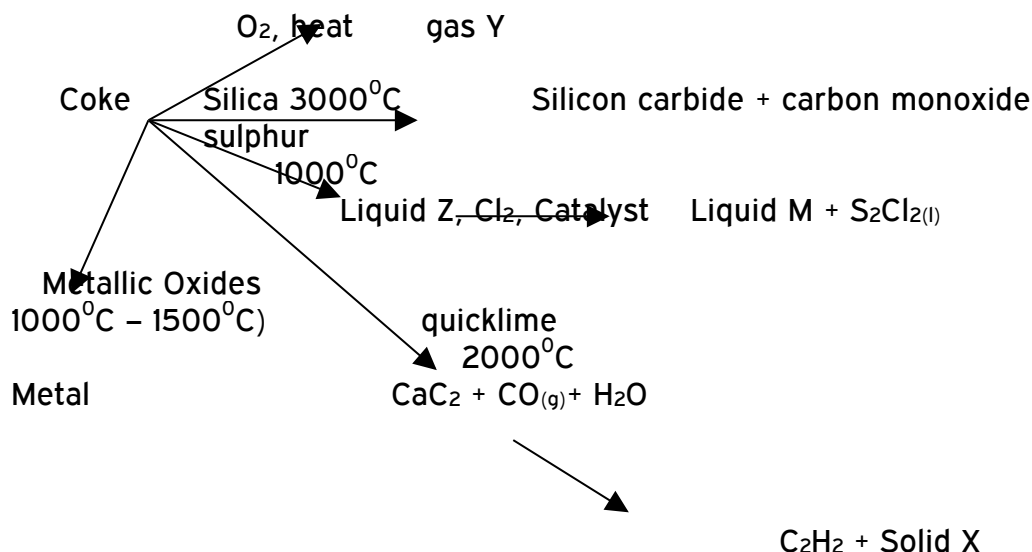

- Name gas Y, liquid Z, liquid M and solid X.
- Write a balanced equation of reaction between silica (a binary compound of silicon) and coke.
- What method would you use to separate the two liquids M and disulphur dichloride
- Write a balanced equation of reaction between calcium carbide and water.
- What is quicklime?
- What property of carbon is illustrated by its reaction with metallic oxides.
- Choose a relevant example of metallic oxide and write its reaction with carbon (coke)

(c) (i) Write three characteristics of wood charcoal and three for graphite.
 (ii) How would you illustrate that the **two** are allotropes of one another.?

4(a) Atomic number and relative atomic mass of carbon are 6 and 12 respectively

- Draw atomic structure of carbon
- Name any covalently bonded compound of carbon and draw its electronic diagram.

(b) How are the atoms

- Arranged in graphite?
- Arranged in diamond?

(c) Use your knowledge of the structure of graphite and diamond to explain at least three of their physical properties.

(d) Diamond and graphite both have giant structure while iodine crystals has iodine molecules;

(i) Explain the statement

(ii) Show how the physical properties can be related to structure

(e) In which group and period is carbon found in periodic Table.

Q5. (a) Below is a diagram of arrangement of apparatus used to study products of a burning candle. Use it to answer the questions that follow.

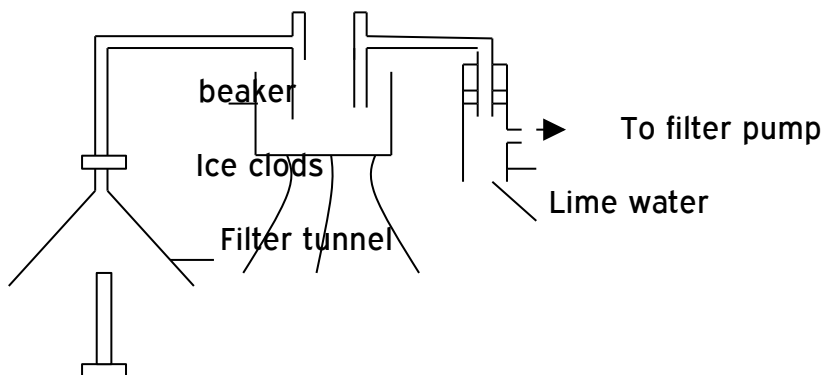

- (i) Compare the flames when the filter pump is on and when it is off.
 - (ii) What was observed in the limewater?
 - (iii) What was observed in the U-tube.
 - (iv) What is the test for product X?
 - (v) Explain your observation in (ii) and (iii) above?
 - (vi) What do your observations tell you about candle wax?
- (b) 224cm^3 of methane, CH_4 and 112cm^3 of ethane, C_2H_6 mixture were burnt in oxygen.
All volumes were measured at s.t.p.
- (i) Write equation of reactions
 - (ii) Calculate the volume of oxygen required to burn the mixture of gases at s.t.p. conditions.
(H = 1, C = 12, O = 16, 1mole of gas at s.t.p. is 22.4cm^3)

NITROGEN AND ITS DERIVATIVES

1. Write down the electronic configuration of nitrogen and state its period and group in the periodic table.

N = 7 electrons 2:5

Period = 2

Group = 5

2. How Nitrogen gas is obtained in a large scale.

– It is obtained by through fractional distillation of air.

3. (i) Taking the assumption that air is a mixture of nitrogen, oxygen and carbon dioxide, describe an experiment to show how nitrogen can be isolated from the mixture.

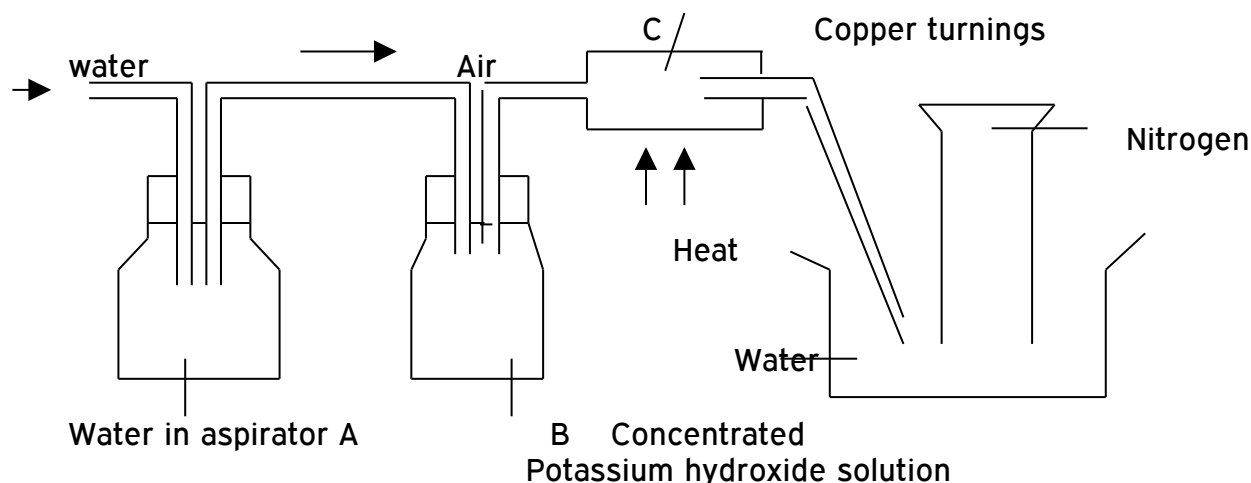

- The aspirator acts as a suction pump to suck water in to displace air.
- The heated copper metal combines chemically with oxygen to form copper oxide. Consequently oxygen in the mixture is irradiated.
- Concentrated potassium hydroxide absorbs the carbon dioxide in the mixture.
- The remaining 78% by volume of the air, Nitrogen gas collects in the jar.

- (ii) Write down the chemical equations to represent the reactions taking place in both B and C.

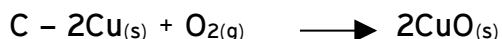
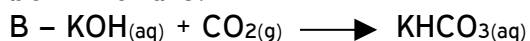

- (iii) List three properties of nitrogen.

- Nitrogen is a colourless, odourless gas
- It is a little less dense than air.
- It is almost insoluble in water.
- Nitrogen is generally unreactive.

- (iv) State three uses of nitrogen.

- In the manufacture of ammonia
- To provide an inert atmosphere
- As a refrigerant

- In light bulbs.

(v) State how pure nitrogen may be obtained.

(a) Pure nitrogen can be obtained by heating ammonium nitrite, NH_4NO_2 .



(b) Pure nitrogen can be obtained by oxidation of ammonia by heated copper II Oxide.



4. (i) List three oxides nitrogen and state their use of each.

(a) Nitrogen dioxide – NO_2 – formation of nitric acid

(b) Dinitrogen oxide – N_2O – as an anaesthetic by dentists and in hospitals for minor surgical operations.

(c) Nitrogen monoxide – NO – Yields NO_2 on oxidation.

5. The diagram below shows the arrangement of the apparatus used to prepare ammonia gas in the laboratory.

(i) Why is the flask containing the mixture arranged in a starting position?

- To prevent the water which condenses on the cooler parts of the apparatus from running back into the flask.

(ii) How would you tell when a test tube or a gas jar is full of ammonia?

- Ammonia if present would turn wet red litmus paper blue for it is the only alkaline gas.

(iii) Why are the usual drying agents, calcium chloride and concentrated Sulphuric acid not used to dry ammonia?

- Ammonia reacts with the usual drying, concentrated sulphuric acid and calcium chloride.

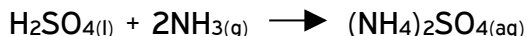
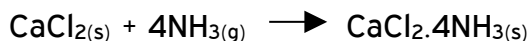

- Calcium oxide doesn't react with ammonia and therefore a suitable drying agent.

(iv) Write equations for the reactions between.

(a) Ammonium chloride and calcium hydroxide.



(b) A hydrochloric acid and ammonia.

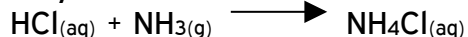

(c) Ammonia and water.

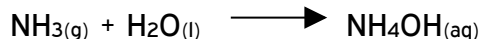

(v) What were the observations made when;

(a) A test tube full of ammonia gas was inverted in water?

- Ammonia would dissolve in water suddenly and the space taken over by the ammonia solution.

(b) A glass rod dipped in concentrated hydrochloric acid was brought near the mouth of a test tube full of ammonia?

- White fumes of ammonium chloride are formed.

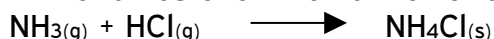

6. Study the following diagram and answer the questions that follow.

(a) What name is given to the experiment

- Fountain experiment
- (b) What is it used for.
- To demonstrated the solubility of very soluble gases.
- (c) Name **two** uses of ammonia.
- In laundry work
- In manufacture of Nitric acid
- Liquid ammonia is used in larger scale refrigeration plants such as in ships and Warehouses.

7. (i) Why is the apparatus in the figure below preferred when making a solution of a highly soluble gas?

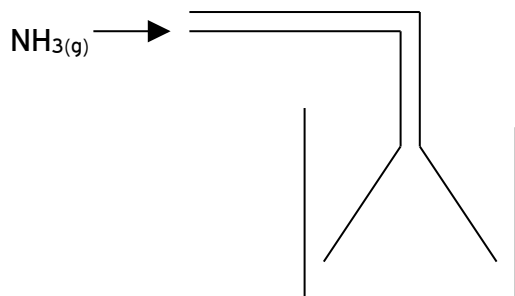

ANS: To prevent 'sucking back' of water into the tube

(ii) In an experiment, a colourless gas W was passed over heated Copper (II) Oxide and the products collected as shown below Copper (II) Oxide.

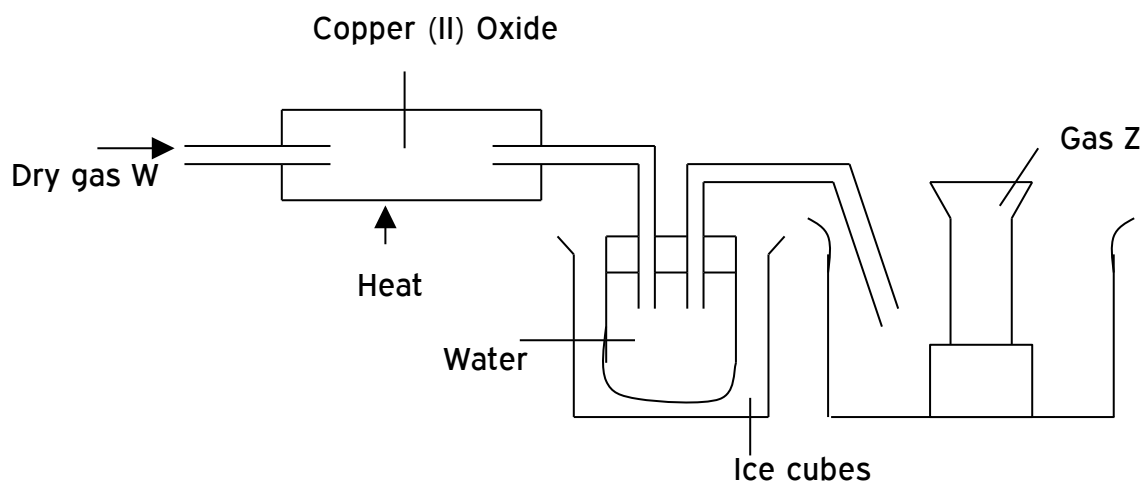

(a) Name gas W and Z.

W – is ammonia

Z – Nitrogen

(b) What properties of the two demonstrated in the above set – up?

W – is a reducing agent.

Z – Insoluble in water.

(c) State the observable changes in the combustion tube.

Copper II Oxide which is black after reduction changes to brown which is the colour of copper metal.

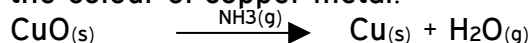

8. (i) In the preparation of nitric acid from sodium nitrate concentrated sulphuric acid is used rather than concentrated hydrochloric acid. Explain why this is the case.

- Concentrated Sulphuric is less volatile hence law displace nitric acid, a more volatile acid, from its salt, where as hydrochloric acid cannot.

(ii) Monicah a student had the following apparatus set-up for the preparation of gas X.

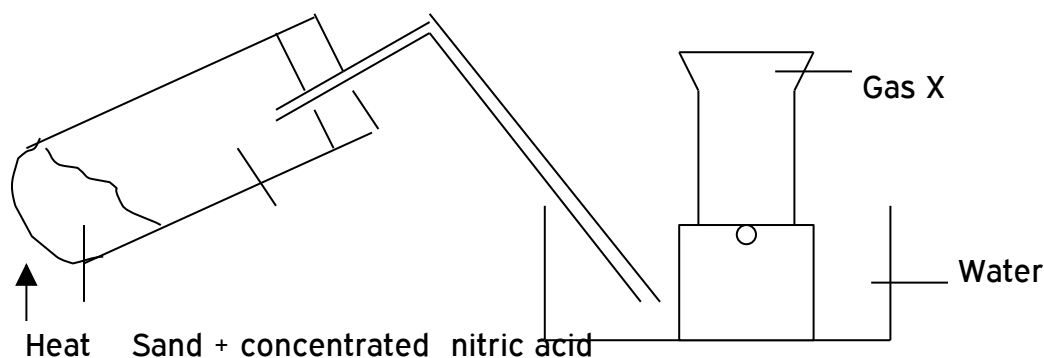

(a) What is the role of sand in this experiment?

- To prevent the 'bumping' of the concentrated nitric acid.

(b) Give an equation for the reaction taking place in the test-tube.



9. The following equation represents the reaction which takes place during the industrial manufacture of ammonia.

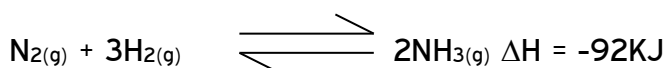

(i) Explain why a pressure of 250 atmospheres and a temperature of 450°C is normally used for the above process.

- A high pressure favours the forward reaction (production of ammonia) since the reaction takes place with decrease in the number of moles. Since the reaction is exothermic, low temperature would favour the production of ammonia but at low temperature the rate of reaction is too slow so a high temperature is used.

(ii) Name a suitable catalyst which is employed in the above process and state its role.

- The catalyst is finely divided Iron. Its role is to speed up the rate of reaction.

(iii) The percentage conversion of nitrogen and hydrogen to ammonia in this process is about 8%. Explain how ammonia could be separated from the unreacted gases.

- Ammonia obtained is liquefied by refrigeration.

(iv) Ammonia can be catalytically converted into nitric acid. Write equation to show how this conversion is done.

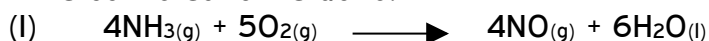

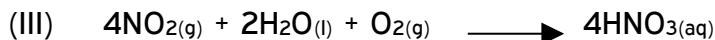
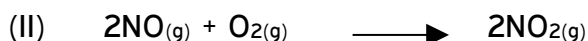

10. Ammonia is manufactured on large scale by the Haber process.

(a) Name the raw materials required for the manufacture of ammonia and state their sources.

- The raw materials are hydrogen and nitrogen. Hydrogen can be obtained from the electrolysis of water or from methane. Nitrogen is obtained from fractional distillation of liquid air.

(b) Discuss the chemical reactions and conditions involved in the Haber process, including relevant chemical equations.

- Nitrogen and hydrogen, mixed in the ratio of 1:3 are reacted together at high pressure of 250 atmospheres over finely divided Iron as a catalyst at a temperature of 500°C. The gases react to form ammonia.



(c) According to the Le-Chatelier's principle, what conditions should be adopted in the Haber process in order to obtain the maximum yield of ammonia?

- Four volumes of reactants form two volumes of products. Increase in pressure will favour the forward reaction since this reaction is accompanied by a decrease in volume. Hence high pressure should increase the yield of ammonia and also increase the rate of reaction; since collision frequency between the reactants will increase. The forward reaction is exothermic hence on decrease in temperature will favour the forward reaction (i.e. conversion of nitrogen and hydrogen to ammonia).

(d) From your answer to part (b) and (c) above, is Le-Chatelier's principle fully obeyed? Why or why not, if not, what are the consequences?

- The high pressure that would favour a high yield of ammonia is not used because with increasing pressure, the cost of the industrial plant becomes more expensive for example, pipes have to be thicker to withstand the pressure. The consequences of using a lower pressure is a lower yield (but at a lower cost).
- According to Le-Chatelier's principle, the yield of ammonia will be greatest at low temperature. However, at low temperature, the rate of attainment of equilibrium is slow, hence a high temperature is used and the consequence of this is lower yield (but in a shorter time).
- At 500°C temperature and 250 atmosphere plus catalyst used, only a 15% yield of ammonia is achieved.

(e) How is ammonia gas isolated for storage?

- The ammonia is removed as an aqueous solution by washing with water or condensed as liquid by refrigeration at -20°C.

(f) What happens to the gases that remain unreacted at the end of the reaction?

- The unreacted hydrogen and nitrogen and uncondensed ammonia are recycled.

(g) State the uses of ammonia.

- Liquid ammonia is used as a refrigerant
- Ammonia is used in the manufacture of nitrogenous fertilizers.
- Ammonia is used in the manufacture of nitric acid and urea.

- IV. Ammonia is used to soften water and as a domestic cleanser since it removes grease.
- V. It is used in the Solvay process for the manufacture of sodium carbonate.
- VI. Is used in the production of synthetic fibres such as nylon – 6,6.

11. (i) **List four ammonium salts and state the uses of each.**

- (a) Ammonium chloride – used as an electrolyte in the manufacture of dry batteries and as a flux in soldering.
- (b) Ammonium sulphate – used as a fertiliser.
- (c) Ammonium nitrate – used as a fertiliser and as an explosive.
- (d) Ammonium carbonate – used in smelling salts, which are used to stimulate breathing.

(ii) **What is the test for ammonium salts?**

- All ammonium salts when heated with an alkali give off ammonia gas which can be recognised by its pungent smell and by turning wet red litmus paper blue.

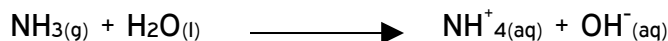

12. **The gases methylamine (CH₅N) and ammonia are closely related compounds and have very similar properties. Each can be represented by the formula**

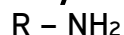

- (i) State what R will be in case of (1) ammonia and (2) methylamine.

- (i) (1) R = H
 (2) Methylamine has the formula CH₃NH₂
 R = CH₃

- (ii) Predict the effect of methylamine on (1) water coloured purple with litmus solution, and (2) hydrogen chloride gas.

- (iii) (1) The litmus solution will turn blue since methylamine is an alkaline gas.
 (2) Methylamine will react with hydrogen chloride to give white fumes, similar to ammonium chloride.

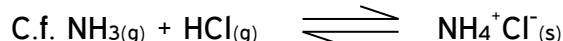
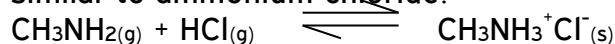

- (iii) A Jet of ammonia is spontaneously inflammable in chlorine producing nitrogen and hydrogen chloride. Write an equation for this reaction.

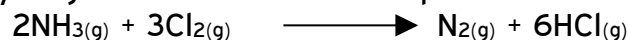

- (iv) What atmospheric conditions are needed for atmosphere nitrogen to be converted into nitrogen compounds.

A lightning flash.

13. (i) **Write the equation for the formation of Nitrogen (II) Oxide from dilute acid and Copper turnings.**



- (ii) What was observed when nitrogen II Oxide was exposed to air?

- The gas is readily oxidised by oxygen, in the air to form brown fumes of nitrogen IV Oxide – NO₂(g).

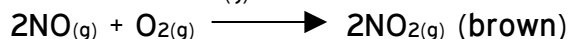

- (iii) What happens to a burning magnesium when it is inverted into a test tube containing nitrogen II Oxide.

- Nitrogen II Oxide oxidises hot elements and is itself reduced to nitrogen.

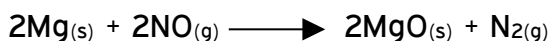

- (iv) What was observed when the gas was passed into a solution of Iron (II) Sulphate? Explain the observation.

- Iron (II) Sulphate turns dark brown when nitrogen II Oxide is bubbled through it due to the formation of ferrous sulphate – nitrogen oxide (Nitroso Iron li sulphate) complex, $\text{FeSO}_4 \cdot \text{NO}$.



N/B. Ferrous sulphate - nitrogen oxide – used in brown ring test for nitrates.

14. (i) What was observed when concentrated nitric was added to copper turnings?

- Brown fumes are observed of nitrogen dioxide.

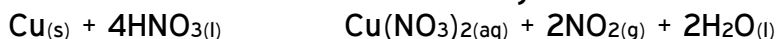

- (ii) What was observed when the gas was

- (a) Cooled?

- On cooling the brown changes to liquid which is pale yellow called dinitrogen tetra oxide

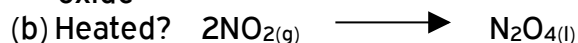

- On heating, this gas dissociates into Nitrogen (II) Oxide and Oxygen.

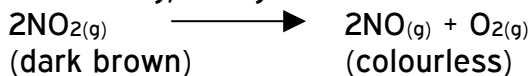

- (iii) List some of the uses of the gas.

- Manufacture of nitric acid;
- As an intermediary in the manufacture of explosive, nylon and plastics.

- (iv) Why does nitric acid appear yellow brown?

- This is due to the dissolved nitrogen IV Oxide which is brown in colour.

- (v) Why doesn't dilute nitric liberate hydrogen with copper metal?

- It is a strong oxidising agent. So any hydrogen initially produced by the action of the acid and the metal is at once oxidised by more of the acid to water.

15. (i) What do you understand by catalytic oxidation of ammonia?

- This is the oxidation of ammonia by oxygen which takes place on the surface of a metallic catalyst e.g. Platinum with the evolution of heat.
- The oxidation is a twin process.



- (ii) How does the ease of decomposition of the metal nitrates relate to the activity series of metals?

- The ease with which the metal nitrates decompose increases down the activity series of the metals.

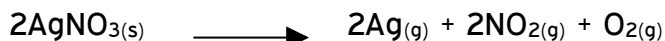
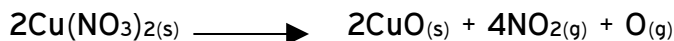

(iii) Explain why Lead nitrate decrepitates on heating.

- When Lead nitrate is heated, it decomposes right from inside the crystal releasing a lot of gas (NO_2 and O_2) which expands on heating exerting pressure on the walls of the crystals until the crystals bursts. Hence the cracking sound of the bursting crystals is heard.

SULPHUR AND ITS DERIVATIVES

1. (a) Name one substance used for vulcanisation of rubber.

Sulphur

- (b) Why is it necessary to vulcanise natural rubber before use?

- To make it harder and stronger and more durable. About 50% addition of Sulphur produces a very hard vulcanite or ebonite.

2. The diagram below represents the extraction of Sulphur by Frasch Process.

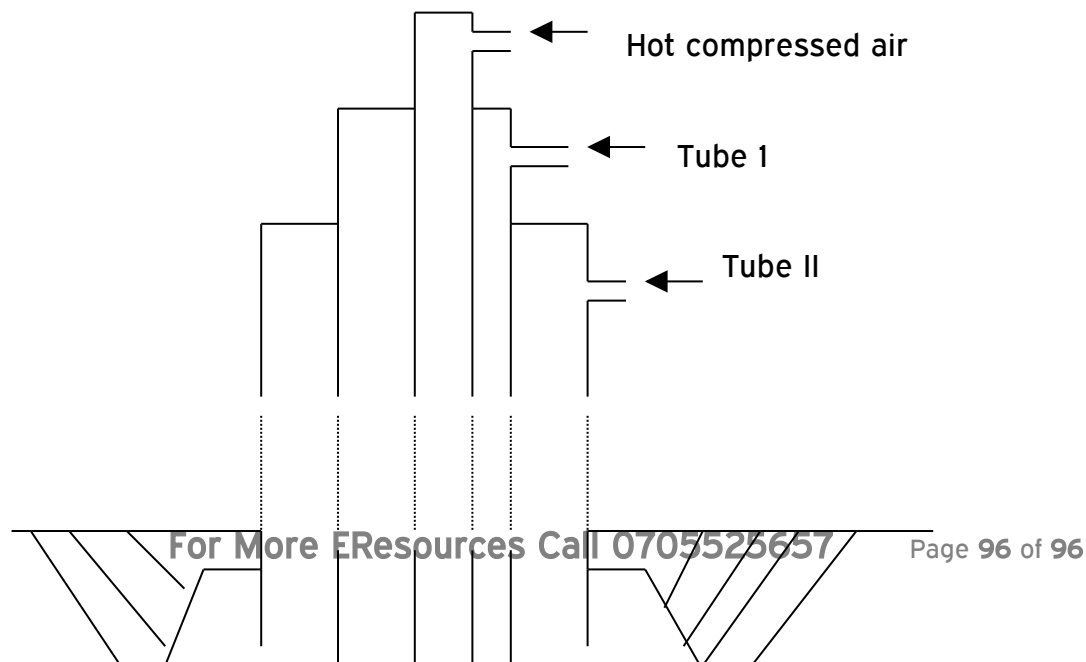

Sulphur

- (a) Name the substance that passes through tube;
 I. – Molten Sulphur
 II. – Superheated water.
- (b) What is the purpose of the hot compressed air in this process?
 – It produces a light froth of molten Sulphur which is forced up the middle pipe.
- (c) In what forms does Sulphur occur in nature?
 – Sulphur occurs in the combined state as PbS, FeS, H₂S, Sulphates and as free element.
- (d) Draw the molecule of Sulphur.

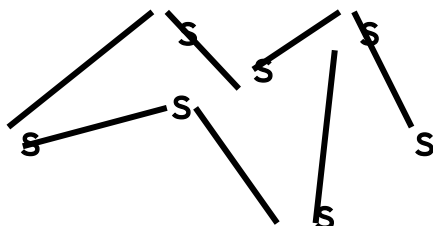

- (e) Explain why it is only soluble in organic solvents and not in water.
 – It has covalent bonds in its structure and hence it can only dissolve in a covalent bond – solvent not in a polar solvent since it has no polarities at all.
- (f) Name the two allotropes of sulphur.
 – Rhombic and monoclinic.
- (g) Which allotropes of sulphur is more stable at room temperature?
 – Rhombic sulphur is stable below 96°C. It is a bright yellow crystalline solid with an octahedral shape.

3. Study the flow chart below and answer the questions that follow.

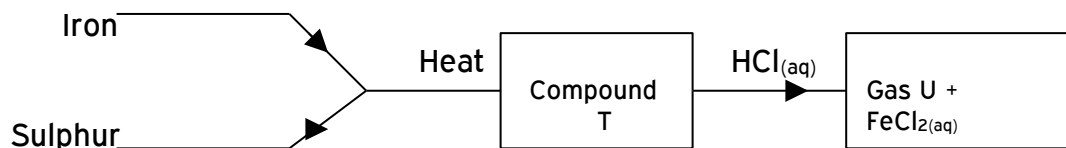

- (a) Name (i) Compound T
 FeS – Iron (II) Sulphide.
 (ii) H₂S – Hydrogen Sulphide.

(b) Give a chemical test that you could use to identify gas U.

Hydrogen Sulphide turns moist Lead (II) acetate paper black, forming Lead II Sulphide.

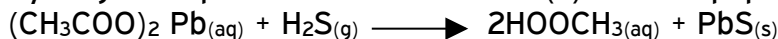

4. (i) List down different types of amorphous sulphide.

- Plastic Sulphur
- Colloidal Sulphur

(ii) State three other uses of sulphur in industries.

- Manufacture of Sulphuric acid
- In the manufacture of matches and gun powders.
- In the production of important chemicals such as carbon disulphide (CS_2) and calcium hydrogen Sulphite ($\text{Ca}(\text{HSO}_3)_2$). The latter is used in the paper industry.

(iii) When a sample sulphur is heated, the changes represented in the flow diagram below are observed.

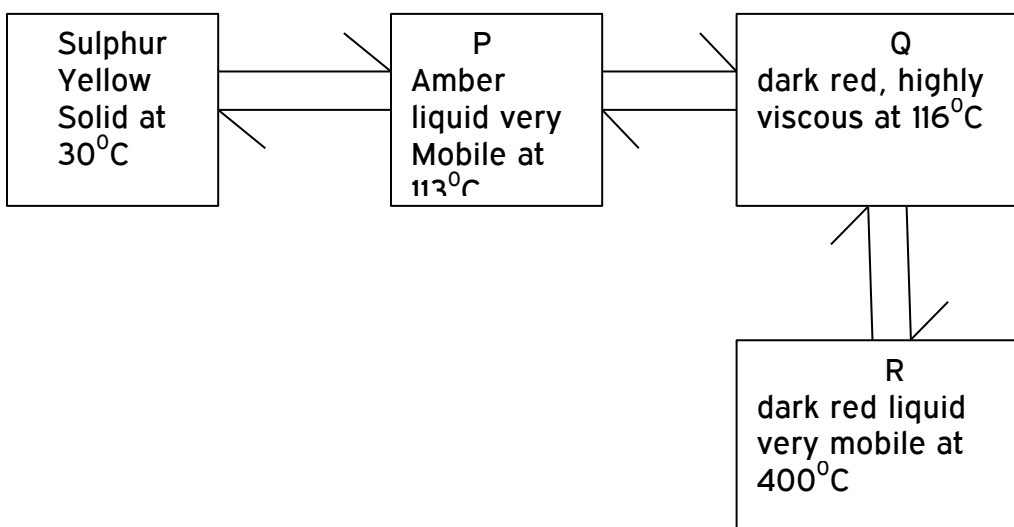

(a) Explain why P and R are very mobile while Q is viscous.

- Because P and R have S_8 , S_6 and S_4 rings while Q has long chains of Sulphur atoms.

(b) What would be observed if the black liquid at 400°C was poured in a thin continuous stream into a beaker containing cold water?

- Long, elastic, light yellow ribbons of plastic sulphur are formed.

(c) When solid sulphur is heated, it melts and becomes mobile, then viscous then mobile again on further heating. Explain this observation in terms of the structures of sulphur.

- The S_8 Sulphur molecules become individual S_8 Sulphur molecules during melting making the liquid mobile. The molecules break open, join to form long chains which get entangled, making the liquid viscous. The chains break, and straighten out. The molecules break into individual sulphur atoms during boiling making the liquid mobile again.

(d) What changes would you observe when powdered roll sulphur is heated in a test

tube to just below its boiling point?

- Sulphur melts at 113°C to give a mobile (runny) amber liquid. As the temperature rises the liquid darkens and at about 180°C it becomes very viscous (thick). If the temperature is increased still further the liquid once more becomes mobile.

(e) Describe how you would prepare two allotropic forms of Sulphur. Make sketches to show the difference in crystal structure.

Rhombic (alpha or octahedral) sulphur

- Dissolve some powdered sulphur in carbon disulphide (CS_2). Filter any excess sulphur using a dry filter paper and collect the filtrate in a water glass and place it in a fume cupboard. Carbon disulphide will evaporate and crystals of rhombic sulphur are formed. Carbon disulphide vapours are highly inflammable and poisonous.
- After the carbon disulphide has evaporated bright yellow crystals of rhombic sulphur form. Through out no heating is required.

Monoclinic (beta or prismatic) sulphur

- Some powdered sulphur is added to 20cm^3 methylbenzene (toluene) or dimethylbenzene (xylene) in a small beaker. The mixture is warmed slowly in a water bath at 313K (40°C) heated with a small flame.
- More powdered sulphur is added if necessary until no more dissolves. The solution is slowly cooled and monoclinic crystals which are pale yellow and needle-like are formed.

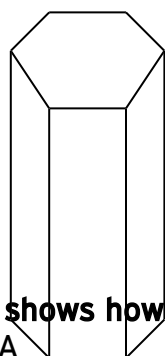

Monoclinic sulphur

5. The flow chart below shows how sulphuric acid is produced on a large scale.

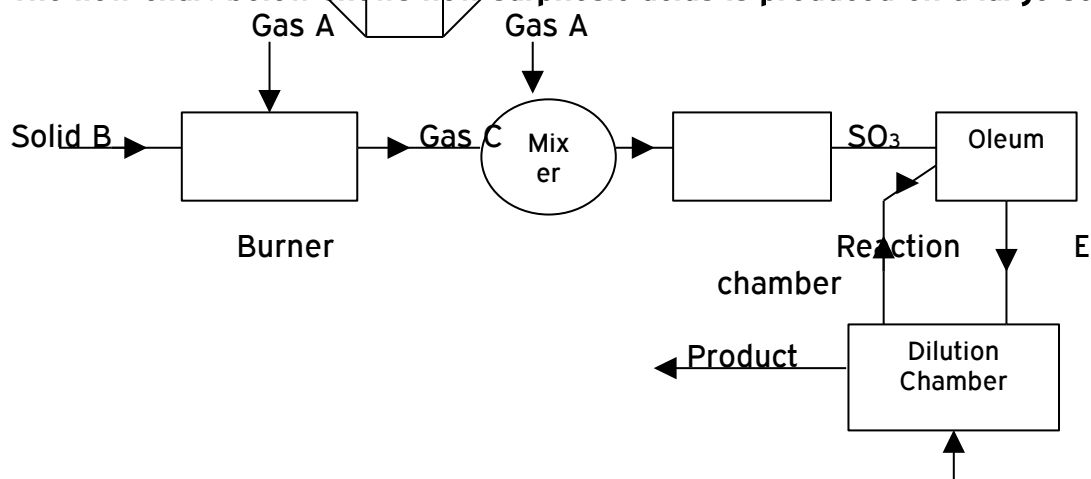

Liquid D

(a) Identify

- (i) Gas B – Sulphur
- (ii) Gas C – Sulphur dioxide, SO₂
- (iii) Liquid D – Water
- (iv) Substance E – H₂SO₄
- (v) Gas A – Air (oxygen)

(b) (i) What catalyst is used in the reaction chamber?

Vanadium (IV) Oxide

(ii) Write an equation for the reaction taking place in this chamber.

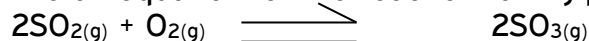

(c) What would you observe if concentrated sulphuric acid is added to.

(i) Cane sugar

- Sugar will get dehydrated and a black carbon remains, a smelling of sulphur dioxide is also noticed.
- The hydrogen and oxygen are removed by the concentrate sulphuric acid.

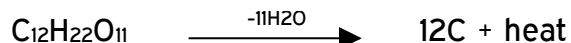

- Heat is also generated and thus reduces some sulphuric acid to sulphur dioxide.

(ii) Copper sulphate crystals.

- The blue copper sulphate crystals gradually turn white as they become anhydrous, losing their water of crystallisation.

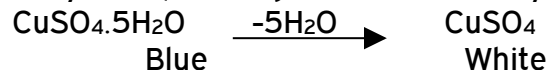

(d) State one use of sulphuric acid.

- In Lead / acid batteries
- Manufacture of fertilizers
- Manufacture of detergents and soaps.
- Used in picking steel.

6. Sulphuric acid is manufactured on large scale by the contact process.

(a) What factors should be considered when siting a plant to manufacture sulphuric acid?

- Availability and cost of raw materials.
- Availability of transport.
- Environmental factors.
- Availability of market.

(b) Name the raw materials required.

- Oxygen
- Sulphur

(c) State the conditions in the contact process.

- Catalyst vanadium pentoxide
- Temperature of 400^o – 500^oC

(d) (i) How concentrated sulphuric acid prepared?

- By diluting the Oleum with water



(ii) How is the unchanged sulphur dioxide removed from the system.

- By absorbing it using calcium hydroxide solution.
- (e) According to Le-chatelier's principle, what conditions should be adopted in the contact process in order to obtain the maximum yield of sulphur trioxide?
 - The conversion of sulphur dioxide to sulphur trioxide is an exothermic process hence a yield of sulphur trioxide is favoured by a reasonably low temperature. Also the reaction proceeds by a decrease in volume. Hence an increase in pressure should increase the yield of sulphur dioxide.

7. Below is a set up of the apparatus that is used to prepare sulphur trioxide.

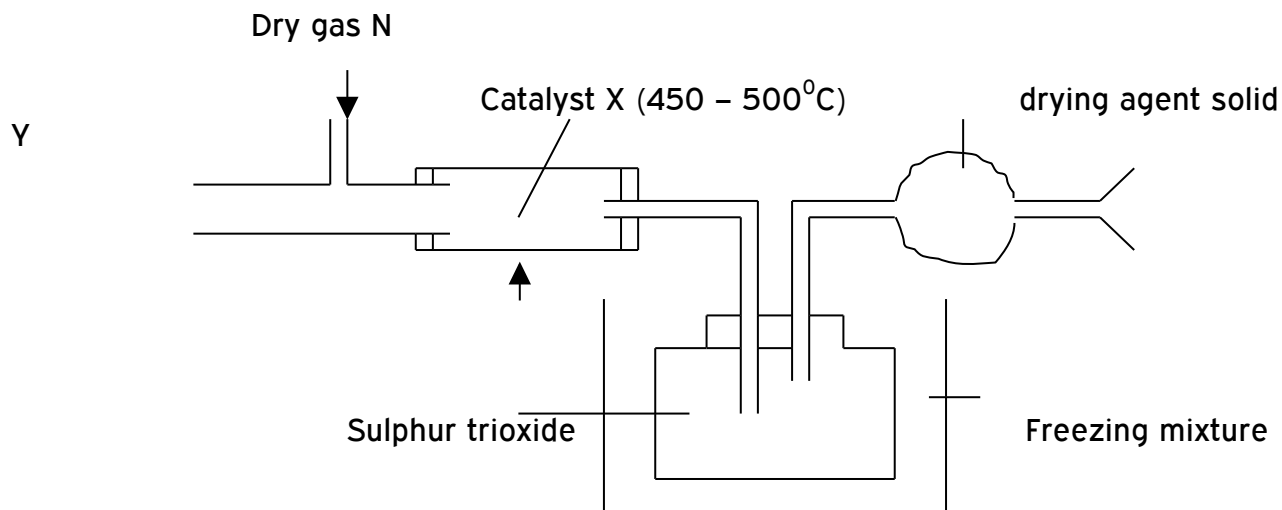

- (a) Name
- I. - Gas N - Sulphur dioxide
 - II. - Gas M - Oxygen
 - III. - Catalyst - Vanadium IV Oxide / Platinum
 - IV. - Solid Y - Anhydrous calcium chloride.
- (b) Why is it necessary to use drying agent solid Y?
- To prevent atmospheric moisture from coming into contact with the sulphur trioxide since moisture would combine with it to form sulphuric acid as shown by the equation.
- $$\text{H}_2\text{O}_{(l)} + \text{SO}_{3(g)} \longrightarrow \text{H}_2\text{SO}_4$$
- (c) Name a suitable liquid drying agent that can be used in drying gas M and N.
Concentrated sulphuric acid.
- (d) Describe briefly a simple laboratory test you use to differentiate between sulphite, sulphate and thiosulphate given the following;
2M Barium chloride solution, dilute hydrochloric acid, filter paper dipped in potassium dichromate and the necessary apparatus.
- To the solution under-test, add barium chloride solution followed by a few drops of dilute hydrochloric acid, test and gas produced using filter paper dipped in acidified potassium dichromate. If a sulphate is present, there will be a faint white precipitate on adding Barium chloride solution and on adding dilute hydrochloric acid, fumes of a pungent gas which turns a filter dipped in acidified potassium dichromate solution from yellow orange to green is produced (SO₂). No precipitate of sulphur is formed.

- If sulphate is present, on adding barium chloride solution followed by hydrochloric acid, a thick white precipitate that is insoluble in dilute hydrochloric acid is formed (BaSO_4)
- If a thiosulphate is present ($\text{S}_2\text{O}_3^{2-}$) on adding barium chloride solution, a white precipitate (BaS_2O_3) is formed and on adding dilute hydrochloric, a white or cream precipitate of sulphur is formed and a colourless gas with a pungent smell and which turns acidified potassium dichromate paper from yellow orange to green is formed (SO_2).

8. Why concentrated sulphuric acid used as a drying agent.

- It has a water loving acid owing to its dehydrating properties hence it is used to dry those gases which don't react with it.

9. Why does a burning magnesium ribbon continue burning in sulphur dioxide gas.

- When burning magnesium is lowered in a jar of sulphur dioxide the heat from the magnesium decomposes the sulphur dioxide into a yellow specks.

***SIMPLIFIED HIGH SCHOOL NOTES & REVISION KITS* (Mr Isaboke)**

Maths form 1-4

English form 1-4

kiswahili form 1-4

chemistry form 1--4

Biology form 1-4

Physics form 1--4

Agriculture form 1--4

Business form 1--4

Cre form 1--4

History form 1--4

Computer form 1--4

Geography form 1--4

isabokemicah@gmail.com

Homescience fl--4

I.R.E studies fl-4

French notes

Setbooks guides

Primary school notes

KCSE Topicals

***CPA* tuitioning**

Updated *CPA,CIFA ATD* KASNEB notes

Updated *CPS,CICT,ATD* KASNEB Notes

Updated *ICT,IT,ACCA,CFA* notes

Forex trading guidance

***CCTV* installation &Networking services**

Online services

_All the materials are in soft copy and well updated

Text /call *0705525657* or WhatsApp INBOX to get your copy_*